

Linear Orifice® Shock Absorber Series

NEW

KSHY Series

Side load resistant
Linear Orifice® Shock Absorber

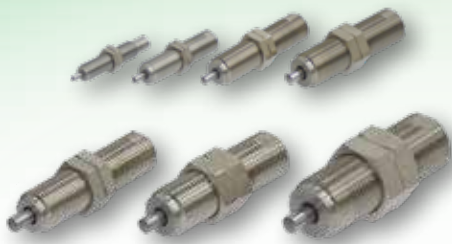

- No need for an angle of eccentricity adaptor
- Each size can withstand up to 10°
- Maximum of more than 2 million operation cycles!

* Specifications in inches are not available.



KSHP Series

Adjustment Type Shock Absorber

- Shortened takt time
- Uses NSF certified H1 oil (non silicon)
- Maximum of more than 3million operation cycles!

KSHJ Series

Fixed type Shock Absorber

- 18 sizes and 132 models
- Supports a wide variety of impact masses
- Maximum of more than 2million operation cycles!
(800,000 operation cycles for M30 and higher)

KSHC Series

Clean Room Specification Shock Absorber

- Low dust emissions and Class 5 equivalent (FED-STD Class 100 equivalent)
- Non silicon
- Maximum of more than 2million operation cycles!

The KSHY series eliminates concerns about absorbing shocks from rotating loads!

Side load resistant Linear Orifice®

Shock Absorber **NEW** KSHY Series

* "Linear Orifice" is a registered trademark of Koganei Corporation.
* Specifications in inches are not available.

New release of our linear orifice models for shock absorbers with side load resistant!

This shock absorber lineup consists of 7 thread sizes from M6 to M20

Maximum of more than 2 million operation cycles!

The unique linear orifice structure, which is used in many applications, provides a long service life

Cap can also be selected as an option

Compliant with H1 grade food equipment specifications!

Uses NSF H1 grade oil (non silicon).

Contributes to space saving!

Integrated a main unit and a side load bearing.
Can be used without an adaptor to handle rotary side load!

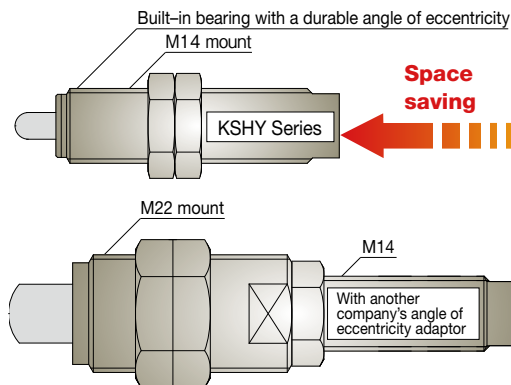

* Illustration

Since you do not need an adaptor, you can also save space with the mounting unit (screw hole)!

Spherically machined



With cap

Wide range of variations

M6 to M20

7 sizes 132 models





With cap





List of linear orifice shock absorber products

[Specifications in mm]





Size	Basic mounting type	Durable angle of eccentricity	Adjustable type	Clean specification	Options		
	KSHJ	KSHY	KSHP	KSHC	Cap	Stopper nut	Side mount
M4 × 0.5	●			●	 Plastic cap		
M6 × 0.75	●	●	●	●			
M8 × 0.75	●	●	●	●			
M8 × 1	●	●	●	●			
M10 × 1	●	●	●	●			
M12 × 1	●	●	●	●			
M14 × 1.5	●	●	●	●			
M16 × 1.5	●	●	●	●			
M18 × 1.5	●		●				
M20 × 1.5	●	●	●	●			
M22 × 1.5	●						
M25 × 1.5	●		●	●			
M25 × 2	●						
M27 × 1.5	●						
M27 × 3	●						
M30 × 1.5	●		●				
M33 × 1.5	●						
M36 × 1.5	●		●				
M42 × 1.5	●		●				
M45 × 1.5	●						
M48 × 2	●						

[Specifications in inches]

Size	Basic mounting type	Adjustable type	Clean specification	Options	
	KSHJ	KSHP	KSHC	Cap	Stopper nut
10-32 UNF	●		●	 Plastic cap	
1/4-32 UNEF	●	●	●		
5/16-32 UNEF	●	●	●		
3/8-32 UNEF	●	●	●		
7/16-28 UNEF	●	●	●		
1/2-20 UNF	●	●	●		
9/16-18 UNF	●	●	●		
3/4-16 UNF	●	●	●		
1-12 UNF	●	●	●		
1 1/4-12 UNF	●	●			
1 3/8-12 UNF	●	●			
1 3/4-12 UN	●	●			

Before selecting and using the products, please read all the "Safety Precautions" carefully to ensure proper product use. The Safety Precautions described below are to help you use the product safely and correctly, and to prevent injury or damage to you, other people, and assets. Be sure to observe these safety precautions together with the following safety regulations of ISO4414 (Pneumatic fluid power - General rules and safety requirements for systems and their components), and JIS B 8370 (General rules relating to systems).

The directions are ranked according to degree of potential danger or damage: "DANGER", "WARNING", "CAUTION" and "ATTENTION."

 DANGER	Indicates situations that can be clearly predicted as dangerous. Death or serious injury may result if the situation is not avoided. It could also result in damage or destruction of assets.
 WARNING	Indicates situations that, while not immediately dangerous, could become dangerous. Death or serious injury may result if the situation is not avoided. It could also result in damage or destruction of assets.
 CAUTION	Indicates situations that, while not immediately dangerous, could become dangerous. Failure to avoid the situation creates the risk of minor or semi-serious injury. It could also result in damage or destruction of assets.
 ATTENTION	It could also result in damage or destruction of assets. appropriate use of the product.

■ This product was designed and manufactured for use in general industrial machinery.

- When selecting and handling equipment, the system designer or another person with sufficient knowledge and experience should always read the "Safety Precautions", "catalog", "instruction manual", and other literature before commencing operation. Improper handling is dangerous.
- After reading the instruction manual, catalog, and other documentation, always place them in a location that allows easy availability for reference to users of this product.
- Whenever transferring or lending the product to another person, always attach the catalog, instruction manual, and other information to the product where they are easily visible in order to ensure that the new user can use the product safely and properly.
- The danger, warning and caution items listed under these "Safety Precautions" do not cover all possible contingencies. Read the catalog and instruction manual carefully, and always keep safety first.

 **DANGER**

- Do not use the product for the purposes listed below:
 1. Medical equipment related to maintenance or management of human lives or bodies.
 2. Machines or equipment designed for the purpose of moving or transporting people.
 3. Critical safety components in mechanical devices.
 This product has not been planned or designed for purposes that require high levels of safety. Using the product in any of the ways described above creates the risk of loss of human life.
- Do not use the product in locations with or near dangerous substances such as flammable or ignitable substances. This product is not explosion-proof. It could ignite or burst into flames.
- When mounting the product and workpiece, always make sure they are firmly supported and secured in place. Ensure the mounting material is strong enough. If the product falls over, is dropped, or breaks, it may result in injury.
- Never attempt to modify the product in any way. Doing so can cause an abnormal operation and create the risk of injury, etc.
- Never attempt inappropriate disassembly, assembly or repair of the product relating to basic construction, or to its performance or to functions. This can lead to injury, etc.
- Do not splash water on the product. Spraying it with water, washing it, or using it under water could result in malfunction leading to injury, etc.
- While the product is in operation, avoid touching it with your hands or otherwise approaching too close. Also, do not mount shock absorbers or make adjustments while the equipment is in operation. The equipment may move suddenly, possibly resulting in injury.

 **WARNING**

- Do not use the product in excess of its specification range. Doing so creates the risk of product breakdown, loss of function, or damage. It could also drastically reduce operating life.
- The small screw on the back end of the shock absorber should never be loosened or removed. Oil may leak out of the shock absorber leading to a loss of functionality and resulting in injury.
- When conducting any kind of operation for the product, such as maintenance, inspection, repair, or replacement, always turn off the air supply and power to the equipment and make sure that the equipment is completely stopped.
- When mounting the product, always follow the handling instructions and precautions. Also when mounting the product, before operation, check that the mounting nut is tightened and not loose and then operate the product. If the mounting nut is loose, etc., this will result in damage to the equipment and accidents.
- Do not allow the product to be thrown into fire. The product could explode, ignite, and/or release toxic gases.

- Do not apply a load to the product, or place other objects on it. It could lead to damaged or broken products that result in degraded performance, function stops, etc.
- If the product has not been used for over 30 days, it is possible that the contacting parts may have become stuck, leading to abnormal operation at impact. Check for proper operation a minimum of once every 30 days.
- Do not use the product at the beach in direct sunlight, near mercury lamps, or near equipment that generates ozone. Ozone causes rubber components to deteriorate resulting in reduced performance, or a limitation or stop of functions.

 **CAUTION**

- Do not use in locations that are subject to direct sunlight (ultraviolet rays); locations with high humidity and temperature, dust, salt, or iron powder; or in locations with fluids and/or ambient atmosphere that include organic solvents, phosphate ester type hydraulic oil, sulfur dioxide, chlorine gas, acids, etc. It could lead to early shutdown of some functions, a sudden degradation of performance, and a reduced operating life. For information about materials, see Major Parts and Materials.
- When installing the product, be sure to allow adequate work space around it. Failure to do so will make it more difficult to conduct daily inspections or maintenance, which could eventually lead to system shutdown or damage to the product.
- When transporting or mounting a heavy product, firmly support the product using a lift or support, or use multiple people to ensure personal safety. Also, wear protective gloves and use safety shoes etc. for protection as necessary.
- Always post an "operations in progress" sign for installations, adjustments, or other operations, to avoid unintentional supplying of air or electrical power, etc. Unintentional supplying of air or electrical power can cause the equipment to operate and may result in injury.
- Never apply lubrication to the product sliding parts. This leads to changes in the physical properties and deterioration of the materials used, resulting in reduced functionality.
- Attempting to use the shock absorber with a cap over the specification range could result in damage to the cap or to its flying off and causing personal injury. Moreover, if cracks or fractures appear in the cap, replace it as quickly as possible.
- Always wash your hands thoroughly after touching the oil or grease used on the shock absorber. There is a danger that the grease or oil from your hands will get on the cigarette and burn, releasing toxic gases, as you smoke the cigarette.
- As a means to prevent vibration, do not use the product at a high frequency that exceeds the value in the catalog. It could drastically reduce the product's operating life.
- When using the shock absorber, gradually increase the speed of the impact object. Suddenly increasing the speed when using the shock absorber may damage the device or injure someone.

 **ATTENTION**

- Whenever considering use of this product in situations or environments not specifically noted in the catalog or instruction manual, or in applications where safety is an important requirement such as in aircraft equipment, combustion equipment, leisure equipment, safety equipment, and other places where human life or assets may be greatly affected, take adequate safety precautions such as allowing plenty of margin for ratings and performance, or fail-safe measures. Contact the sales department of Koganei regarding use in such applications.
- When the product can no longer be used, or is no longer necessary, dispose of it appropriately, according to the "Law Regarding the Disposal and Cleaning of Waste" or other local governmental rules and regulations, as industrial waste. Incinerating the special oil in the KSHC series (clean specification) or the KSHJ series (short stroke type) generates hazardous fluorine (HF), which is corrosive and toxic. Because of this, incineration must be done in an incinerator that has neutralizing equipment that can handle acids. For large amounts, ask a registered waste disposal company.
- The product can exhibit degraded performance and function over its operating life. Always conduct daily inspections and confirm that all requisite system functions are satisfied, to prevent accidents from happening.
- When handling the product, wear protective gloves, safety glasses, safety shoes, and other protective clothing.
- The maximum absorption in the specifications are for a normal temperature (20 to 25°C [68 to 77°F]). Be aware that performance and characteristics change depending on the operating temperature.
- The shock absorber's absorption capacity changes depending on the speed of the impacting object. Use the product within the ranges of the selection graphs.
- For inquiries about the product, consult your nearest Koganei sales office or Koganei Overseas Department. The addresses and telephone numbers are shown on the back cover of this catalog.

 **Other**

- Always observe the following items.
 1. When using this product in a system, use only genuine Koganei parts or equivalent (recommended) parts. When conducting maintenance and repairs, always use genuine Koganei parts or compatible parts (recommended parts). Always observe the prescribed methods and procedures.
 2. Never attempt unauthorized disassembly or assembly of the product relating to its basic construction, its performance, or its functions.

Koganei shall not be held responsible for any problems that occur as a result of these items not being properly observed.

Warranty and General Disclaimer

1. **Warranty Period**
Koganei warrants this product for a period of no more than 1 year from delivery.
* However, some products have a 2-year warranty; contact your nearest Koganei sales office or the Koganei Technical Service Center for details.
2. **Scope of Warranty and General Disclaimer**
 - (1) When a product purchased from Koganei or from an authorized Koganei distributor malfunctions during the warranty period in a way that is found to be attributable to Koganei responsibility, Koganei will repair or replace the product free of charge. Even if a product is still within the warranty period, its durability is determined by its operation cycles and other factors. Contact your nearest Koganei sales office or the Koganei overseas department for details.
 - (2) The Koganei product warranty covers only the product itself. Therefore, Koganei is not responsible for incidental losses (repair of the product, various expenses required for replacement, etc.) caused by breakdown, loss of function, or loss of performance of Koganei products.
 - (3) Koganei shall not be held responsible for any losses or for any damage to other machinery caused by breakdown, loss of function, or loss of performance of Koganei products.
 - (4) Koganei shall not be held responsible for any losses due to use or storage of the product in a way that is outside of the product specifications prescribed in Koganei catalogs and the instruction manual, and/or due to actions that violate the mounting, installation, adjustment, maintenance and other safety precautions.
 - (5) Koganei shall not be held responsible for any losses caused by breakdown of the product due to factors outside the responsibility of Koganei, including but not limited to fire, natural disaster, the actions of third parties, and intentional actions or errors by you.

Side load resistant Linear Orifice[®] Shock Absorber KSHY Series

Now on
sale!

Side load resistant
Linear Orifice[®] Shock Absorber

Can be used without an adaptor to handle rotary side load!
Stopper unnecessary

Each size can withstand up to 10°

Maximum of more than 2 million operation cycles!



Wide range of variations

M6 to M20

7 sizes 132 models

KSHJ

KSHY

KSHP

KSHC

Additional Parts

Handling instructions and precautions



General precautions

Cover the unit when mounting it in locations where it might be subject to excessive dust, dripping water, dripping oil, etc. Dents, scratches, water, oil, or dust on the piston rod results in damage and decreases service life.



Mounting

1. Keep the angle of eccentricity, resulting from the load direction and the axis of the shock absorber, under the specified values on page 49. If an eccentric load exceeding the specifications is applied, it could result in breakage or impaired returns. If there is concern that an eccentric load exceeding the specified values will be applied, install a guide, or similar mechanism.

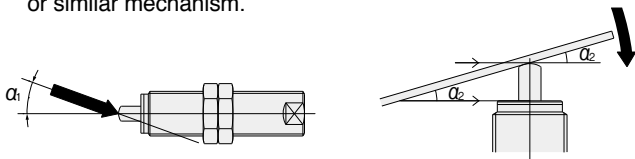

2. For swing impacts, the ends of the piston rod and the cap wear down due to the sliding between the contact area and the tip of the shock absorber. Although you can reduce wear by applying grease, observe the following precautions when applying grease.

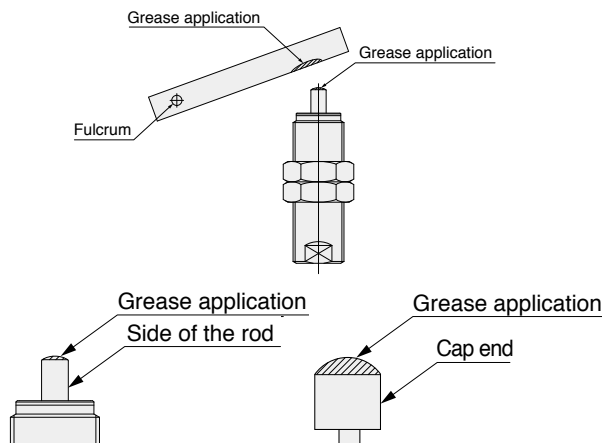

- * Grease application: Apply a small amount and spread it thinly.
- * Wipe off the grease if it gets stuck to the cap end or the side of the rod.
- * If grease gets inside the body of the shock absorber and excessively increases its inner volume, the pressure inside the shock absorber will rise when absorbing an impact and cause damage due to the plug popping out, or other similar situations. Make sure not to apply grease excessively.

3. Ensure that the hardness of the surface directly impacting the piston rod of the shock absorber is over HRC40 hardness (excluding models with cap). We also recommend a surface roughness of Ry6.3 or less.

4. Angle of eccentricity specification shock absorbers can be used very effectively if they are mounted at a position far from the center of rotation. However, use shock absorbers with a thrust stronger than the returning force of the spring (return force of the piston rod).

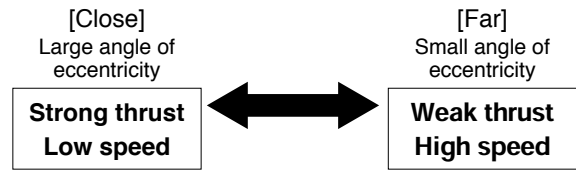

Large shock absorber

Small shock absorber

5. Two or more shock absorbers can be mounted in parallel, to boost absorption capacity. However, keep the distances from the center of rotation to each shock absorber equal. Also, have the load applied evenly between each shock absorber.

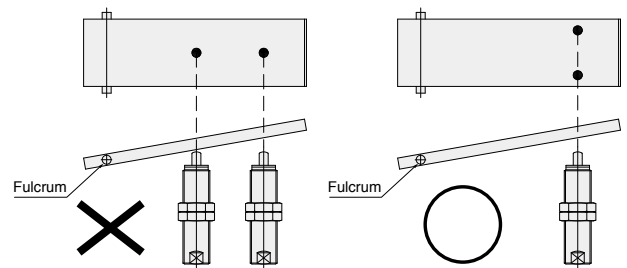

6. To adjust the capacity with the stroke, adjust the stopper nut (-S) or add an external stopper.

7. If using with a cap, always mount a stopper nut (-S) or an external stopper to ensure that the cap is not subjected to loads at the stroke end. Install the mounting position of the stopper nut such that $A \leq$ the stroke of the shock absorber. You can use it without a stopper nut or external stopper, but over the long-term, the stop location changes due to cap deformation and wear.

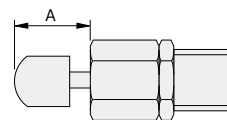

8. The small screw on the back end of the shock absorber should never be loosened or removed. Oil may leak out of the shock absorber leading to a loss of functionality and resulting in damage to the equipment and accidents.

9. When mounting the shock absorber, always use the following maximum tightening torque guidelines. Tightening using excessive force may result in damage.

Model	Maximum tightening torque
KSHY6 × 4 (C)-01,-02	0.85
KSHY8 × 5 (C)-01,-02,-11,-12	2.5
KSHY10 × 6 (C)-01,02	6.5
KSHY12 × 6 (C)-01,02	8.0
KSHY14 × 8 (C)-01,02	12.0
KSHY16 × 8 (C)-01,02	20.0
KSHY20 × 10 (C)-01,02	30.0

10. Be aware that performance and characteristics change depending on the operating temperature.

Selection guidelines

How to select durable angle of eccentricity shock absorbers

1. Confirm the thrust
Choose a shock absorber from its allowable thrust.



2. Confirm the angle of eccentricity
Confirm that the shock absorber selected in step 1 can be used under the allowable angle of eccentricity.



3. Confirm the absorption capacity
Confirm that the absorption capacity of the shock absorber is sufficient.



- 3-1. Confirm the impact speed
- 3-2. Confirm the absorption capacity of the shock absorber
- 3-3. Calculate the moment of inertia
- 3-4. Calculate the kinetic energy

4. Confirm other specifications
Confirm any specifications other than the angle of eccentricity and absorption capacity.

1. Confirm the thrust

The thrust that is applied to the shock absorber (F) should be weaker than the allowable thrust. If a thrust stronger than the allowable thrust is used, the shock absorber may be damaged in fewer operation cycles than the guaranteed life. See page 36 for the values of allowable thrust.

When using an rotating actuator

$$F = T \div R$$

T: Torque of the rotating actuator [N·m]

R: Shock absorber's mounting radius (the distance from the center of rotation to the shock absorber) [m]

F: Force at the point of distance Rm (thrust applied to the shock absorber) [N]

When using a linear actuator

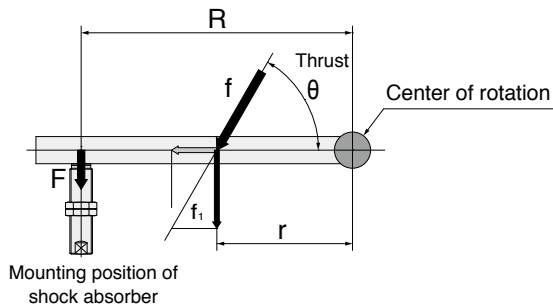

$$f_1 = f \times \sin \theta$$

$$T = f_1 \times r = F \times R$$

$$F = (f \times \sin \theta \times r) \div R$$

f : Thrust of linear actuator [N]

f₁: Force acting on the direction of rotation [N]

r : Mounting position of actuator's end [m]

If the value for F is greater than the allowable thrust, do the following countermeasures.

- Use a larger size shock absorber
- Make R, the mounting radius, larger

2. Confirm the angle of eccentricity

Confirm whether the approximate value for angle of eccentricity of the prospective shock absorbers may be less than 10°. Finally, you should check on the device's drawings since, in actuality, the angles for even the same radii may differ, depending on the shapes and the mounting methods.

If a workpiece is installed so that it contacts the plug of the shock absorber, in parallel, at the stroke end, its approximate angle of eccentricity and minimum mounting radius are as follows.

These are not the actual values because the rotating parts have some thickness.

These are reference values for when you are making a selection.

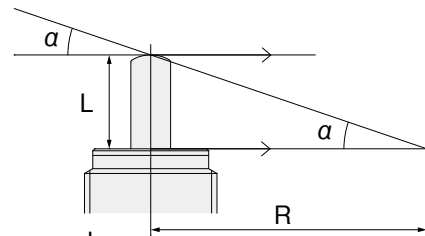

$$10^\circ \geq \alpha = \tan^{-1} \left(\frac{L}{R} \right)$$

L: Shock absorber's stroke [mm]

R: Shock absorber's mounting radius [mm]

α : Deflection angle [°]

Model	Stroke[mm]	Allowable angle of eccentricity	Minimum mounting radius [mm]
KSHY6 × 4 (C)	4	10° or less	22.7
KSHY8 × 5 (C)	5		28.4
KSHY10 × 6 (C)	6		34
KSHY12 × 6 (C)			45.4
KSHY14 × 8 (C)	8		56.7
KSHY16 × 8 (C)			56.7
KSHY20 × 10 (C)	10		

If the allowable angle of eccentricity is exceeded, do the following countermeasures, and then do [1. Confirm the thrust] again.

- Make R, the mounting radius, larger
- Use a smaller size shock absorber

Continue on the next page →

3. Confirm the absorption capacity
4. Confirm other specifications

Selection guidelines

3. Confirm the absorption capacity

3-1. Confirm the impact speed

$$\text{Angular velocity } \omega \text{ [rad/s]} = \frac{\text{Swing angle [rad]}}{\text{Target swing time [s]}} \times 2^{\text{Note}}$$

Swing angle [°] $\times \pi \div 180 =$ Swing angle [rad] ($90^\circ \doteq 1.57\text{rad}$)

Velocity at the shock absorber's mounting position

$$V[\text{m/s}] = R \times \omega \leq \text{Maximum impact speed (1 m/s)}$$

Note: Because the impact speed, not the average speed, is needed, calculate with twice the value of this.

3-2. Confirm the absorption capacity of the shock absorber

If you are using the impact speed, V, found in step 3-1, confirm the exhibited absorption capacity of the shock absorber (e.g. [J]) on the selection graph on page 40. The maximum absorption capacity is reached only when used at the maximum impact speed. The absorption capacity of the shock absorber changes, depending on the operating speed, because the drag of the oil is strong when the flow rate is fast and weak when the flow rate is slow.

3-3. Calculate the moment of inertia

Find the moment of inertia for the impact object I [kg·m²] to calculate the kinetic energy. If the impact object is rotating, you cannot make a selection by only using the impact object mass because the kinetic energy differs depending on the shape, even if the weight is the same. Calculate the approximate value by referring to the diagram for calculating the moment of inertia (pages 41 to 42).

3-4. Calculate the kinetic energy

Confirm that the kinetic energy of the impact object is less than the absorption capacity of the shock absorber.

$$\text{Kinetic energy of the impact object } E \text{ [J]} = \frac{1}{2} I \omega^2 \leq E_x$$

Calculating the thrust energy is not necessary because the shock absorber was selected from the allowable thrust in step 1. Assume that the absorption capacity = the allowable kinetic energy.

4. Confirm other specifications

Confirm such specifications as the maximum operating frequency, maximum absorption per unit of time, and operating temperature range.

Selection guidelines

Example selection 1: Using a rotary actuator

<Operating conditions>

When the impact object is a rod

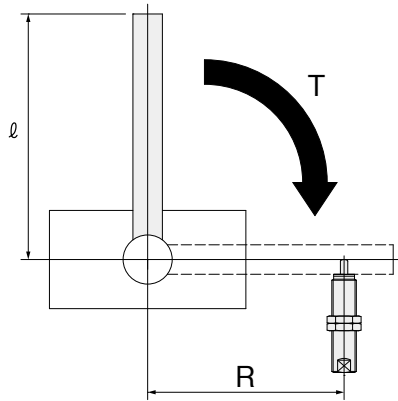

- ① Torque of rotating actuator: $T = 5[\text{N}\cdot\text{m}]$
- ② Absorber's mounting radius: $R = 50[\text{mm}] = 0.05[\text{m}]$
- ③ Impact object mass: $m = 3[\text{kg}]$
- ④ Length from the center of rotation to the end of the rod:
 $l = 120[\text{mm}] = 0.12[\text{m}]$
- ⑤ Angle of rotation: 90°
- ⑥ Target swing time: $0.5[\text{s}]$

1. Confirm the thrust

Find the thrust, F , that is applied to the shock absorber.

$$F = T \div R$$

$$= ① 5[\text{N} \cdot \text{m}] \div ② 0.05[\text{m}]$$

$$= 100[\text{N}]$$

Make a selection from a model (KSHY10 or higher) for an allowable thrust of 100 N or more.
(Refer to page 48 for specifications.)

2. Confirm the angle of eccentricity

Confirm whether the angle of eccentricity is less than the allowable angle of eccentricity (10°).

Assume that KSHY10×6 (body thread size: M10, stroke: 6 mm) is used.

$$\alpha = \tan^{-1}\left(\frac{L}{R}\right)$$

$$= \tan^{-1}\left(\frac{⑥ 6[\text{mm}]}{② 50[\text{mm}]}\right)$$

$$\doteq 6.84^\circ < 10^\circ$$

3. Confirm the absorption capacity

3-1. Confirm the impact speed

Calculate the velocity at which the impact object impacts the shock absorber.

Swing angle $[\circ] \times \pi \div 180 =$ Swing angle [rad]

$$⑤ 90[\circ] \times \pi \div 180 \doteq 1.57\text{rad}$$

Angular velocity ω [rad/sec] = $\frac{\text{Swing angle [rad]}}{\text{Target swing time [s]}} \times 2$

$$\omega = \frac{1.57[\text{rad}]}{⑥ 0.5[\text{s}]} \times 2$$

$$\doteq 6.28[\text{rad/s}]$$

Velocity, V , of the shock absorber's mounting position [m/s]

$$= R \times \omega$$

$$V = ② 0.05[\text{m}] \times 6.28[\text{rad/s}]$$

$$\doteq 0.31[\text{m/s}] < 1\text{m/s}$$

3-2. Confirm the absorption capacity of the shock absorber

Assume that you selected $V = 0.31 \text{ m/s}$ from the selection graph on page 40 and confirm the absorption capacity, E_x , that KSHY10×6 exhibits.

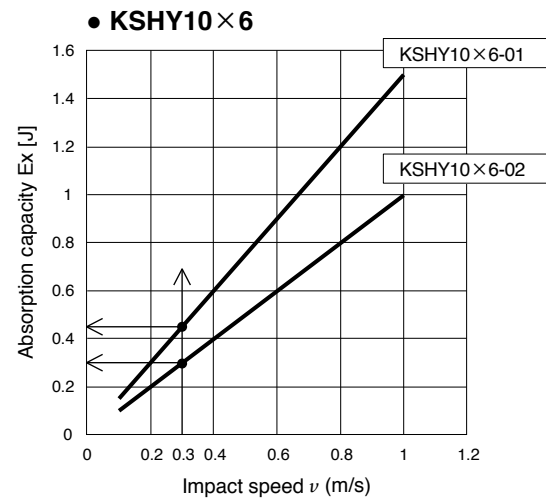

Values for E_x :

KSHY10×6-01: Approx. 0.45 J

KSHY10×6-02: Approx. 0.3 J

3-3. Calculate the moment of inertia

Find the moment of inertia for the impact object I [$\text{kg}\cdot\text{m}^2$] to calculate the kinetic energy.

According to "Rod (end is the center of rotation)", the diagram for calculating the moment of inertia (pages 41 to 42):

$$I = \frac{m l^2}{3}$$

$$= \frac{③ 3[\text{kg}] \times ④ 0.12[\text{m}]^2}{3}$$

$$= 0.0144[\text{kg} \cdot \text{m}^2]$$

3-4. Calculate the kinetic energy

Calculate the kinetic energy of the impact object to confirm whether it is less than the absorption capacity of the shock absorber.

$$\text{Kinetic energy of the impact object } E [\text{J}] = \frac{1}{2} I \omega^2$$

$$E = \frac{1}{2} \times 0.0144[\text{kg}\cdot\text{m}^2] \times (6.28[\text{rad/s}])^2$$

$$= 0.28[\text{J}]$$

Values for E_x found in step 3-2:

KSHY10×6-01: Approx. 0.45 J

KSHY10×6-02: Approx. 0.3 J

The shock absorber with the optimum absorption capacity is KSHY10×6-02 because the smaller the gap between the values for E and E_x is, the lower the impact value and the shorter the operating time.

4. Confirm other specifications

Confirm that other operating conditions, such as the maximum operating frequency, maximum absorption capacity per unit of time, and operating temperature range, are within the specified ranges for KSHY10×6-02.

Selection guidelines

Example selection 2: Using an air cylinder

<Operating conditions>

When the impact object is a rod

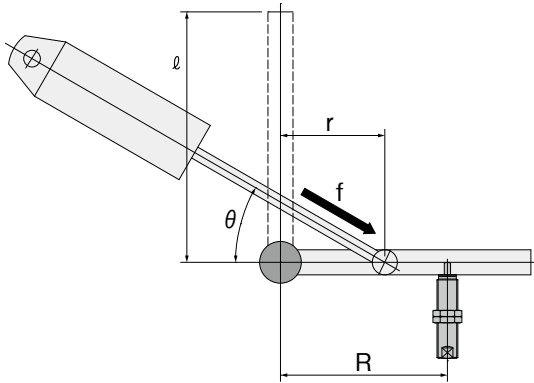

- ① Cylinder thrust: $\Phi 32(0.5\text{MPa}) \rightarrow 402[\text{N}]$
- ② Cylinder thrust angle: $\theta = 30^\circ$
- ③ Mounting position of cylinder's end: $r = 30[\text{mm}] = 0.03[\text{m}]$
- ④ Absorber's mounting radius: $R = 50[\text{mm}] = 0.05[\text{m}]$
- ⑤ Impact object mass: $m = 3[\text{kg}]$
- ⑥ Length from the center of rotation to the end of the rod: $l = 120[\text{mm}] = 0.12[\text{m}]$
- ⑦ Swing angle: 90°
- ⑧ Target swing time: $0.5[\text{s}]$

1. Confirm the thrust

Find the thrust, F, that is applied to the shock absorber.

$$F = (f \times \sin \theta \times r) \div R$$

$$= ① 402[\text{N}] \times ② \sin 30^\circ \times ③ 0.03[\text{m}] \div ④ 0.05[\text{m}]$$

$$= 120.6[\text{N}]$$

Make a selection from a model (KSHY12 or higher) for an allowable thrust of 120.6 N or more.

(Refer to page 48 for specifications.)

2. Confirm the angle of eccentricity

Confirm whether the angle of eccentricity is less than the allowable angle of eccentricity (10°).

Assume that KSHY12×6 (body thread size: M12, stroke: 6 mm) is used.

$$\alpha = \tan^{-1}\left(\frac{L}{R}\right)$$

$$= \tan^{-1}\left(\frac{6[\text{mm}]}{④ 50[\text{mm}]}\right)$$

$$\doteq 6.84^\circ < 10^\circ$$

3. Confirm the absorption capacity

3-1. Confirm the impact speed

Calculate the velocity at which the impact object impacts the shock absorber.

Swing angle $[\circ] \times \pi \div 180 =$ Swing angle [rad]

$$⑦ 90^\circ \times \pi \div 180 \doteq 1.57\text{rad}$$

Angular velocity ω [rad/sec] = $\frac{\text{Swing angle [rad]}}{\text{Target swing time [s]}} \times 2$

$$\omega = \frac{1.57[\text{rad}]}{⑧ 0.5[\text{s}]} \times 2$$

$$\doteq 6.28[\text{rad/s}]$$

Velocity, V, of the shock absorber's mounting position [m/s]

$$= R \times \omega$$

$$V = ④ 0.05[\text{m}] \times 6.28[\text{rad/s}]$$

$$\doteq 0.31[\text{m/s}] < 1\text{m/s}$$

3-2. Confirm the absorption capacity of the shock absorber

From the selection graph on page 40:

Assume that you selected $V = 0.31$ m/s and confirm the absorption capacity, Ex, that KSHY12×6 exhibits.

● KSHY12×6

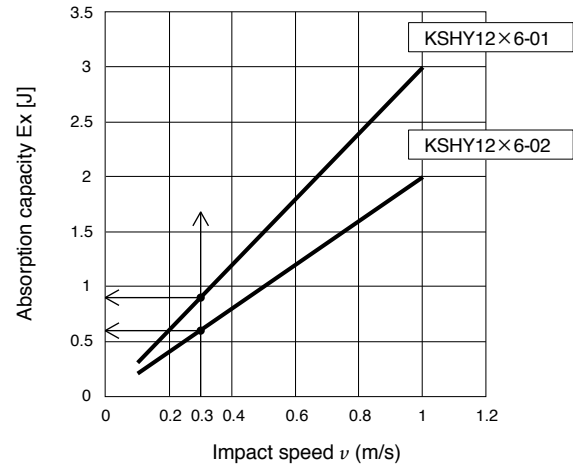

Values for Ex:

KSHY12×6-01: Approx. 0.9 J

KSHY12×6-02: Approx. 0.6 J

3-3. Calculate the moment of inertia

Find the moment of inertia for the impact object I [$\text{kg} \cdot \text{m}^2$] to calculate the kinetic energy.

According to "Rod (end is the center of rotation)", the diagram for calculating the moment of inertia (pages 41 to 42):

$$I = \frac{m \ell^2}{3}$$

$$= \frac{⑤ 3[\text{kg}] \times ⑥ 0.12[\text{m}]^2}{3}$$

$$= 0.0144[\text{kg} \cdot \text{m}^2]$$

3-4. Calculate the kinetic energy

Calculate the kinetic energy of the impact object to confirm whether it is less than the absorption capacity of the shock absorber.

Kinetic energy of the impact object E [J] = $\frac{1}{2} I \omega^2$

$$E = \frac{1}{2} \times 0.0144[\text{kg} \cdot \text{m}^2] \times 6.28[\text{rad/s}]^2$$

$$= 0.28[\text{J}]$$

Values for Ex found in step 3-2:

KSHY12×6-01: Approx. 0.9 J

KSHY12×6-02: Approx. 0.6 J

The shock absorber with the optimum absorption capacity is KSHY12×6-02 because the smaller the gap between the values for E and Ex is, the lower the impact value and the shorter the operating time.

4. Confirm other specifications

Confirm that other operating conditions, such as the maximum operating frequency, maximum absorption capacity per unit of time, and operating temperature range, are within the specified ranges for KSHY12×6-02.

Selection guidelines

Cautions for using the selection graphs

1. Use with an absorption capacity below the capacity curves.
2. The values in the selection graphs are for room temperature (20 to 25°). Be aware that performance and characteristics change depending on the operating temperature.

■ Selection graph

● KSHY6×4

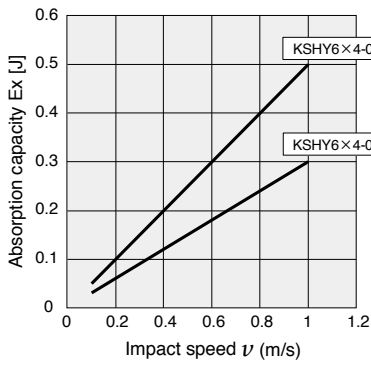

● KSHY8×5

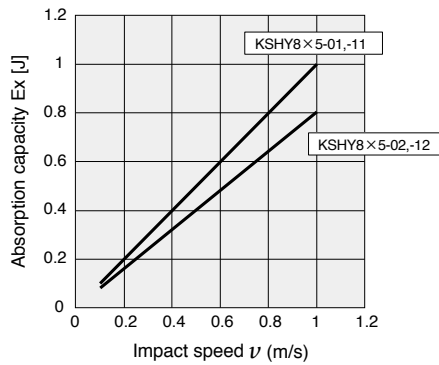

● KSHY10×6

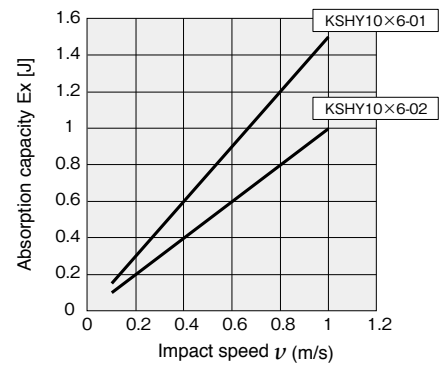

● KSHY12×6

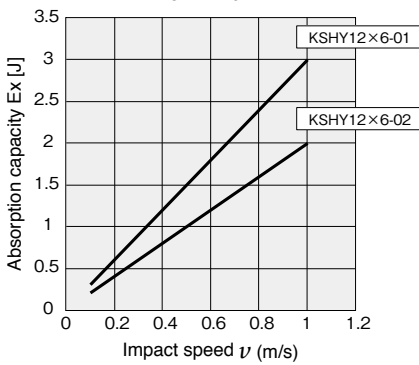

● KSHY14×8

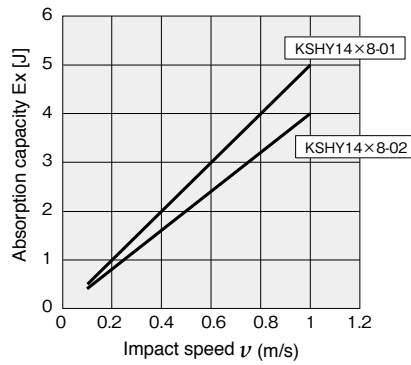

● KSHY16×8

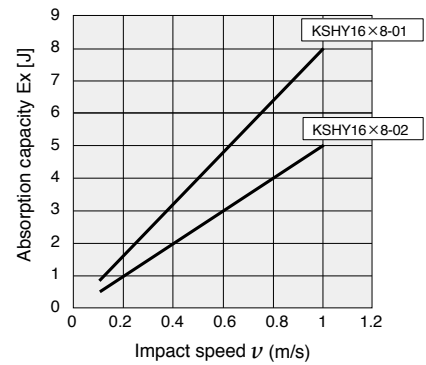

● KSHY20×10

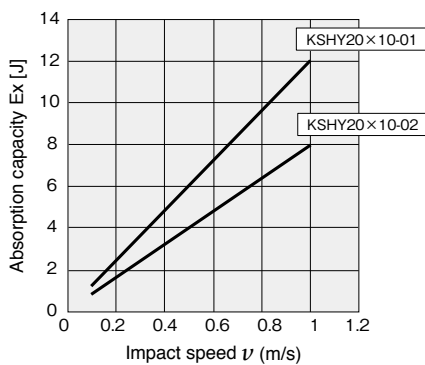

Selection guidelines

■ Diagram for calculating the moment of inertia

[When the rotation axis goes through the workpiece]

● Disk

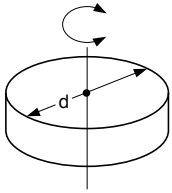

- Diameter
- Mass

d (m)
m (kg)

■ Moment of inertia I [kg·m²]

$$I = \frac{md^2}{8}$$

● Stepped disk

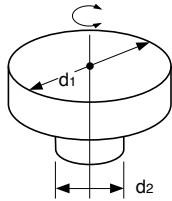

- Diameter
 - Mass
- d₁ (m)
d₂ (m)
d₁ part m₁ (kg)
d₂ part m₂ (kg)

■ Moment of inertia I [kg·m²]

$$I = \frac{1}{8} (m_1 d_1^2 + m_2 d_2^2)$$

■ Radius of rotation

$$\frac{d_1^2 + d_2^2}{8}$$

Remark: The d₂ part can be ignored if it is much smaller compared to the d₁ part.

● Rod (end is the center of rotation)

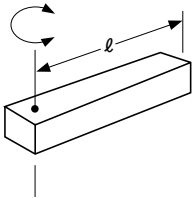

- Rod length
 - Mass
- l (m)
m (kg)

■ Moment of inertia I [kg·m²]

$$I = \frac{ml^2}{3}$$

● Fine rod

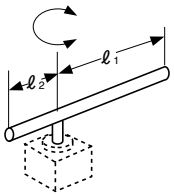

- Rod length
 - Mass
- l₁ (m)
l₂ (m)
m₁ (kg)
m₂ (kg)

■ Moment of inertia I [kg·m²]

$$I = \frac{m_1 \cdot l_1^2}{3} + \frac{m_2 \cdot l_2^2}{3}$$

● Rod (center of gravity is the center of rotation)

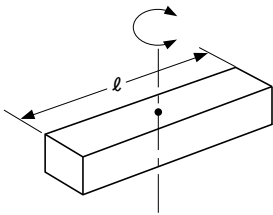

- Rod length
 - Mass
- l (m)
m (kg)

■ Moment of inertia I [kg·m²]

$$I = \frac{ml^2}{12}$$

● Thin, rectangular plate (rectangular parallelepiped)

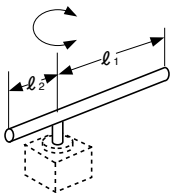

- Plate length
 - Edge length
 - Mass
- a₁ (m)
a₂ (m)
b (m)
m₁ (kg)
m₂ (kg)

■ Moment of inertia I [kg·m²]

$$I = \frac{m_1}{12} (4a_1^2 + b^2) + \frac{m_2}{12} (4a_2^2 + b^2)$$

● Rectangular parallelepiped

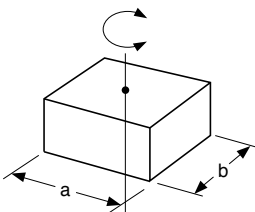

- Edge length
 - Mass
- a (m)
b (m)
m (kg)

■ Moment of inertia I [kg·m²]

$$I = \frac{m}{12} (a^2 + b^2)$$

Selection guidelines

● Concentrated load

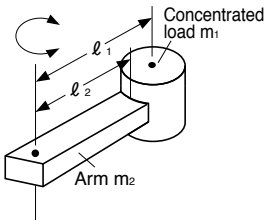

- Shape of concentrated load
- Length to the concentrated load's center of gravity
- Arm length
- Mass of the concentrated load
- Mass of the arm

l_1 (m)
 l_2 (m)
 m_1 (kg)
 m_2 (kg)

■ Moment of inertia I [kg·m²]

$$I = m_1 k^2 + m_1 l_1^2 + \frac{m_2 l_2^2}{3}$$

Radius of rotation: k^2 is calculated according to the shape of the concentrated load.
 Remark: When m_2 is much smaller compared to m_1 , it is okay to calculate $m_2 = 0$.

[When the rotation axis is off set from the workpiece]

● Rectangular parallelepiped

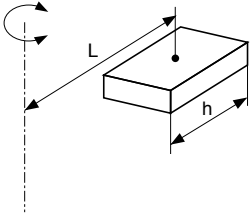

- Edge length
- Distance from the rotation axis to the center of the load
- Mass

h (m)
 L (m)
 m (kg)

■ Moment of inertia I [kg·m²]

$$I = \frac{mh^2}{12} + mL^2$$

Remark: Same as for cube

● Hollow rectangular parallelepiped

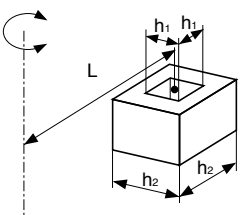

- Edge length
- Distance from the rotation axis to the center of the load
- Mass

h_1 (m)
 h_2 (m)
 L (m)
 m (kg)

■ Moment of inertia I [kg·m²]

$$I = \frac{m}{12}(h_2^2 + h_1^2) + mL^2$$

Remark: Cross-section is a cube only

● Cylinder

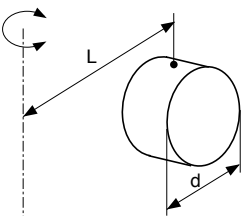

- Diameter
- Distance from the rotation axis to the center of the load
- Mass

d (m)
 L (m)
 m (kg)

■ Moment of inertia I [kg·m²]

$$I = \frac{md^2}{16} + mL^2$$

● Hollow cylinder

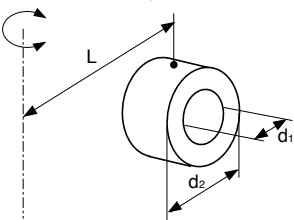

- Diameter
- Distance from the rotation axis to the center of the load
- Mass

d_1 (m)
 d_2 (m)
 L (m)
 m (kg)

■ Moment of inertia I [kg·m²]

$$I = \frac{m}{16}(d_2^2 + d_1^2) + mL^2$$

Linear orifice shock absorber

KSHY Series



Specifications

Item	Model	KSHY6×4-01		KSHY6×4-02		KSHY8×5-01,-11		KSHY8×5-02,-12	
Maximum absorption capacity	J	0.5		0.3		1		0.8	
Stroke	mm	4		4		5		5	
Impact speed range	m/s					0.1 to 1.0			
Allowable thrust		27.5N or less		27.5N or less		60.3N or less		60.3N or less	
Maximum operating cycle	cycle/min					60		60	
Maximum absorption capacity per unit of time	J/min	18		18		36		36	
Spring return force ^{Note1}	N	3.5		3.5		6.5		6.5	
Deflection angle						10° or less		10° or less	
Operating temperature range ^{Note2}	°C					0 to 60		0 to 60	

Item	Model	KSHY10×6-01		KSHY10×6-02		KSHY12×6-01		KSHY12×6-02	
Maximum absorption capacity	J	1.5		1		3		2	
Stroke	mm	6		6		6		6	
Impact speed range	m/s					0.1 to 1.0		0.1 to 1.0	
Allowable thrust		100N or less		100N or less		157N or less		157N or less	
Maximum operating cycle	cycle/min					60		60	
Maximum absorption capacity per unit of time	J/min	45		45		80		80	
Spring return force ^{Note1}	N	8.5		8.5		15.5		15.5	
Deflection angle						10° or less		10° or less	
Operating temperature range ^{Note2}	°C					0 to 60		0 to 60	

Item	Model	KSHY14×8-01		KSHY14×8-02		KSHY16×8-01		KSHY16×8-02		KSHY20×10-01		KSHY20×10-02	
Maximum absorption capacity	J	5		4		8		5		12		8	
Stroke	mm	8		8		8		8		10		10	
Impact speed range	m/s									0.1 to 1.0		0.1 to 1.0	
Allowable thrust		245N or less		245N or less		402N or less		402N or less		628N or less		628N or less	
Maximum operating cycle	cycle/min	60		60		40		40		40		40	
Maximum absorption capacity per unit of time	J/min	100		100		130		130		200		200	
Spring return force ^{Note1}	N	14.5		14.5		14.5		14.5		21.5		21.5	
Deflection angle						10° or less		10° or less		10° or less		10° or less	
Operating temperature range ^{Note2}	°C					0 to 60		0 to 60		0 to 60		0 to 60	

Note 1: The spring return force cannot be used as a function because it is the return force of the piston rod at full stroke, making it unstable.

Note2: The shock absorbing capacity fluctuates based on speed and ambient temperature. Always use a product that is within the range shown by the solid lines in the graphs on pages 40.

Mass

Model	Body ^{Note}	Additional mass		Additional parts' mass		
		With plastic cap	Mounting nut (1 ea.)	Stopper nut	Side mounting bracket	
KSHY6×4-01, -02	4.5	0.2	0.4	3	8	
KSHY8×5-01, -11	9	0.4	0.6(0.9)	4	12	
KSHY10×6-01, -02	20.1	0.8	1.2	7	15	
KSHY12×6-01, 02	32	1.3	1.9	8	22	
KSHY14×8-01, 02	53	2.3	4	15	41	
KSHY16×8-01, -02	70	2.3	6.6	28	65	
KSHY20×10-01, -02	129	5	12.2	55	110	

Calculation example: The mass of KSHY10×6C-01-S-2 (with cap, stopper, and side mount) is
 $20+1.3+7+15 = 43.3g$

Note: The weight of the main unit includes the weight of 2 mounting nuts.

Inner Construction and Major Parts and Materials

●KSHY6×4

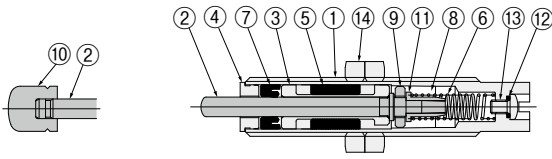

●KSHY8 to 20

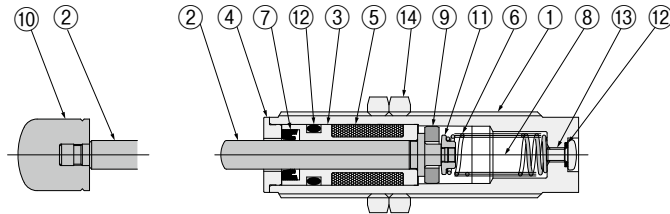

No.	Name	Materials
①	Body ^{Note 1}	Copper alloy (nickel plated)
②	Piston rod ^{Note 2}	Stainless steel,
③	Sleeve	Copper alloy
④	Plug	Stainless steel
⑤	Accumulator	Synthetic rubber
⑥	Spring	Spring steel
⑦	Rod seal	Synthetic rubber
⑧	Oil	Special oil
⑨	Piston ring	Stainless steel,
⑩	Cap	Plastic (POM)
⑪	Collar ^{Note 3}	Stainless steel,
⑫	O-ring	Synthetic rubber
⑬	Screw ^{Note 4}	Mild steel (zinc plated)
⑭	Mounting nut	Mild steel (nickel plated)

Note1: KSHY6 and 8 are stainless steel

Note2: Shock absorbers with no caps undergo a quenching treatment.

Note3: KSHY6 and 8 are copper alloy

KSHY10 and 12 are sintered metal

Note4: KSHY6 and 8 are nickel plated

Order Codes

KSHY [] - [] - [] - []

Mounting bracket

Blank: No mounting bracket

2 : With side mounting bracket (side mounting type)

Stopper nut

Blank: No stopper nut

S : With stopper nut

Thread pitch and absorption capacity

01: For heavy loads

02: For light loads

11: For heavy loads with different thread pitches

12: For light loads with different thread pitches (11 and 12 set to 8x5 only, M8x1)

Cap
Blank: No cap
C : With cap

Body thread size × stroke

6×4
8×5
10×6
12×6
14×8
16×8
20×10

Durable angle of eccentricity specification
Linear orifice Shock absorber
KSHY Series

Additional Parts

●Mounting nut (1 pack has 10 units)

N - KSH - M []



Thread size
6: KSHY6
8: KSHY8
8-11: KSHY8-11
10: KSHY10
12: KSHY12
14: KSHY14
16: KSHY16
20: KSHY20

●Stopper nut

S - KSH - M []



Thread size
6-L: KSHY6
8: KSHY8
8-11: KSHY8-11
10: KSHY10
12: KSHY12
14: KSHY14
16: KSHY16
20: KSHY20

●Side mounting bracket

2 - KSH - M []



Thread size
6: KSHY6
8: KSHY8
8-11: KSHY8-11
10: KSHY10
12: KSHY12
14: KSHY14
16: KSHY16
20: KSHY20

* For the dimension diagrams of the additional parts, see pages 72 to 76.

* The stopper nut and side mount are made from mild steel (nickel plated).

Dimensions (mm)

●KSHY6×4-□

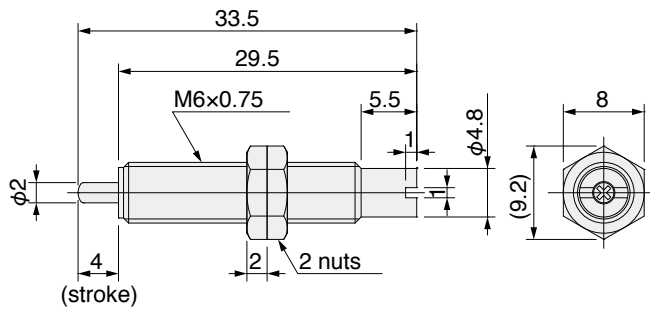

●KSHY6×4C-□

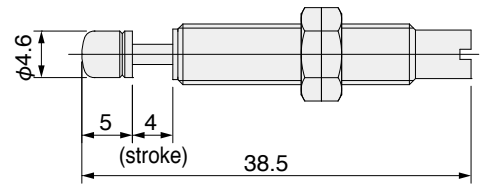

●KSHY8 to 20

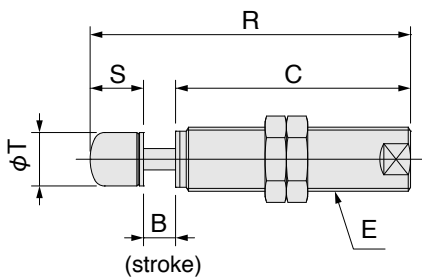
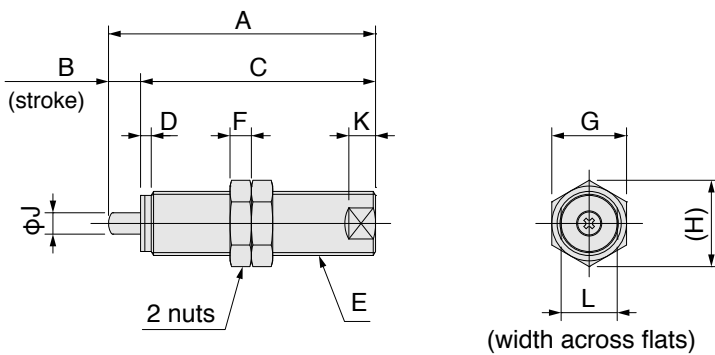

Model	Symbol	A	B	C	D	E	F	G	H	J	K	L	R	S	T
KSHY8 × 5 (C)-01,-02		36	5	31	1.2	M8 × 0.75	2	10	11.5	2.5	3	7	42	6	6.5
KSHY8 × 5 (C)-11,-12		36	5	31	1.2	M8 × 1	3	10	11.5	2.5	3	7	42	6	6.5
KSHY10 × 6 (C)-01,-02		46	6	40	2	M10 × 1	3	12	13.9	3	5	8.5	55	9	8
KSHY12 × 6 (C)-01,-02		50	6	44	2	M12 × 1	4	14	16.2	4	5	10.5	60	10	10
KSHY14 × 8 (C)-01,-02		61	8	53	2	M14 × 1.5	5	17	19.6	5	5	12	72	11	11
KSHY16 × 8 (C)-01,-02		61	8	53	3	M16 × 1.5	7	19	21.9	5	7	13	72	11	11
KSHY20 × 10 (C)-01,-02		69	10	59	3	M20 × 1.5	8	24	27.7	6	7	17	84	15	15

Dimensions of Additional Parts (mm)

● Mounting nut: N-KSH-□-□

N-KSH-M45 (for KSHJ45)

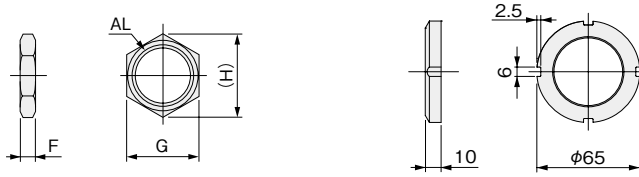

Symbol Model	AL	F	G	H	Applicable shock absorbers			
					KSHJ	KSHY	KSHP	CS-KSHC
N-KSH-M4	M4×0.5	2	5.5	6.4	KSHJ4	—	—	CS-KSHC3
N-KSH-M6	M6×0.75	2	8	9.2	KSHJ6	KSHY6	KSHP6	CS-KSHC4
N-KSH-M8	M8×0.75	2	10	11.5	KSHJ8(-01,02)	KSHY8(-01,02)	KSHP8	CS-KSHC5
N-KSH-M8-11	M8×1	3	10	11.5	KSHJ8(-11,12)	KSHY8(-11,12)	KSHP8-11	CS-KSHC5-11
N-KSH-M10	M10×1	3	12	13.9	KSHJ10	KSHY10	KSHP10	CS-KSHC6
N-KSH-M12	M12×1	4	14	16.2	KSHJ12	KSHY12	KSHP12	CS-KSHC8
N-KSH-M14	M14×1.5	5	17	19.6	KSHJ14	KSHY14	KSHP14	CS-KSHC9
N-KSH-M16	M16×1.5	7	19	21.9	KSHJ16	KSHY16	KSHP16	CS-KSHC11
N-KSH-M18	M18×1.5	8	21	24.2	KSHJ18	—	KSHP18	—
N-KSH-M20	M20×1.5	8	24	27.7	KSHJ20	KSHY20	KSHP20	CS-KSHC14
N-KSH-M22	M22×1.5	9	27	31.2	KSHJ22	—	—	—
N-KSH-M25	M25×1.5	10	30	34.6	KSHJ25-01	—	KSHP25	CS-KSHC18
N-KSH-M25-11	M25×2	10	30	34.6	KSHJ25(-11,12)	—	—	—
N-KSH-M27	M27×1.5	10	36	41.6	KSHJ27(-01,02)	—	—	—
N-KSH-M27-11	M27×3	12	36	41.6	KSHJ27(-11,12)	—	—	—
N-KSH-M30	M30×1.5	10	36	41.6	KSHJ30	—	KSHP30	—
N-KSH-M33	M33×1.5	10	41	47.3	KSHJ33	—	—	—
N-KSH-M36	M36×1.5	15	46	53.1	KSHJ36	—	KSHP36	—
N-KSH-M42	M42×1.5	15	50	57.7	KSHJ42	—	KSHP42	—
N-KSH-M48	M48×2	15	55	63.5	KSHJ48	—	—	—

● Stopper nut: S-KSH-□-□ (-2)

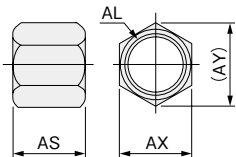

Symbol Model	AL	AS	AX	AY	Applicable shock absorbers			
					KSHJ	KSHY	KSHP	CS-KSHC
S-KSH-M4	M4×0.5	7.5	5.5	6.4	KSHJ4	—	—	CS-KSHC3
S-KSH-M6	M6×0.75	7	8	9.2	KSHJ6	—	KSHP6	CS-KSHC4
S-KSH-M6-L	M6×0.75	10	8	9.2	—	KSHY6	—	—
S-KSH-M8	M8×0.75	11	10	11.5	KSHJ8(-01,02)	KSHY8(-01,02)	KSHP8	CS-KSHC5
S-KSH-M8-11	M8×1	11	10	11.5	KSHJ8(-11,12)	KSHY8(-11,12)	KSHP6-11	CS-KSHC5-11
S-KSH-M10	M10×1	17	12	13.9	KSHJ10	KSHY10	KSHP10	CS-KSHC6
S-KSH-M12	M12×1	17	14	16.2	KSHJ12	KSHY12	KSHP12	CS-KSHC8
S-KSH-M14	M14×1.5	18	17	19.6	KSHJ14	KSHY14	KSHP14	CS-KSHC9
S-KSH-M16	M16×1.5	30	19	21.9	KSHJ16	KSHY16	KSHP16	CS-KSHC11
S-KSH-M18	M18×1.5	35	21	24.2	KSHJ18	—	KSHP18	—
S-KSH-M20	M20×1.5	35	24	27.7	KSHJ20	KSHY20	KSHP20	CS-KSHC14
S-KSH-M22	M22×1.5	40	27	31.2	KSHJ22	—	—	—
S-KSH-M25	M25×1.5	40	30	34.6	KSHJ25-01	—	KSHP25	CS-KSHC18
S-KSH-M25-11	M25×2	40	30	34.6	KSHJ25(-11,12)	—	—	—
S-KSH-M27	M27×1.5	40	36	41.6	KSHJ27(-01,02)	—	—	—
S-KSH-M27-11	M27×3	40	36	41.6	KSHJ27(-11,12)	—	—	—
S-KSH-M30	M30×1.5	40	36	41.6	KSHJ30	—	KSHP30	—
S-KSH-M33	M33×1.5	40	41	47.3	KSHJ33	—	—	—
S-KSH-M36	M36×1.5	50	46	53.1	KSHJ36	—	KSHP36	—
S-KSH-M42	M42×1.5	50	50	57.7	KSHJ42	—	KSHP42	—
S-KSH-M45	M45×1.5	60	55	63.5	KSHJ45	—	—	—
S-KSH-M48	M48×2	60	55	63.5	KSHJ48	—	—	—

KSHJ

KSHY

KSHP

KSHC

Additional Parts

Dimensions of Additional Parts (mm)

●Side mounting bracket: 2-KSH-□-□ (-2)

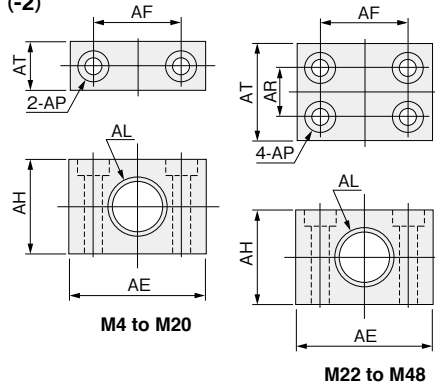

Symbol Model	AE	AF	AH	AL	AP	AR	AT	Applicable shock absorbers			
								KSHJ	KSHY	KSHP	CS-KSHC
2-KSH-M4	18	12	8	M4×0.5	φ 3.4, φ 6.5 Counter bore depth3.3	—	8	KSHJ4	—	—	CS-KSHC3
2-KSH-M6	18	12	10	M6×0.75	φ 3.4, φ 6.5 Counter bore depth3.3	—	8	KSHJ6	KSHY6	KSHP6	CS-KSHC4
2-KSH-M8	19	13	13	M8×0.75	φ 3.4, φ 6.5 Counter bore depth3.3	—	9	KSHJ8(-01,02)	KSHY8(-01,02)	KSHP8	CS-KSHC5
2-KSH-M8-11	19	13	13	M8×1	φ 3.4, φ 6.5 Counter bore depth3.3	—	9	KSHJ8(-11,12)	KSHY8(-11,12)	KSHP8-11	CS-KSHC5-11
2-KSH-M10	22	14	14	M10×1	φ 3.4, φ 6.5 Counter bore depth3.3	—	9	KSHJ10	KSHY10	KSHP10	CS-KSHC6
2-KSH-M12	25	16	18	M12×1	φ 3.4, φ 6.5 Counter bore depth3.3	—	9	KSHJ12	KSHY12	KSHP12	CS-KSHC8
2-KSH-M14	34	22	22	M14×1.5	φ 4.5, φ 8 Counter bore depth4.5	—	10	KSHJ14	KSHY14	KSHP14	CS-KSHC9
2-KSH-M16	38	25	25	M16×1.5	φ 4.5, φ 8 Counter bore depth4.5	—	12	KSHJ16	KSHY16	KSHP16	CS-KSHC11
2-KSH-M18	50	34	30	M18×1.5	φ 6.5, φ 11 Counter bore depth6.5	—	12	KSHJ18	—	KSHP18	—
2-KSH-M20	50	34	30	M20×1.5	φ 9, φ 14 Counter bore depth8.5	—	16	KSHJ20	KSHY20	KSHP20	CS-KSHC14
2-KSH-M22	60	44	35	M22×1.5	φ 9, φ 14 Counter bore depth8.5	19	35	KSHJ22	—	—	—
2-KSH-M25	60	44	35	M25×1.5	φ 9, φ 14 Counter bore depth8.5	19	35	KSHJ25-01	—	KSHP25	CS-KSHC18
2-KSH-M25-11	60	44	35	M25×2	φ 9, φ 14 Counter bore depth8.5	19	35	KSHJ25(-11,12)	—	—	—
2-KSH-M27	60	44	44	M27×1.5	φ 9, φ 14 Counter bore depth8.5	19	35	KSHJ27(-01,02)	—	—	—
2-KSH-M27-11	60	44	44	M27×3	φ 9, φ 14 Counter bore depth8.5	19	35	KSHJ27(-11,12)	—	—	—
2-KSH-M30	60	44	46	M30×1.5	φ 9, φ 14 Counter bore depth8.5	19	35	KSHJ30	—	KSHP30	—
2-KSH-M33	100	70	62	M33×1.5	φ 18, φ 26 Counter bore depth18	50	80	KSHJ33	—	—	—
2-KSH-M36	100	70	62	M36×1.5	φ 18, φ 26 Counter bore depth18	50	80	KSHJ36	—	KSHP36	—
2-KSH-M42	100	70	62	M42×1.5	φ 18, φ 26 Counter bore depth18	50	80	KSHJ42	—	KSHP42	—
2-KSH-M45	120	85	70	M45×1.5	φ 22, φ 32 Counter bore depth22	45	80	KSHJ45	—	—	—
2-KSH-M48	120	85	70	M48×2	φ 22, φ 32 Counter bore depth22	45	80	KSHJ48	—	—	—

Limited Warranty

KOGANEI CORP. warrants its products to be free from defects in material and workmanship subject to the following provisions.

Warranty Period The warranty period is 180 days from the date of delivery.

Koganei Responsibility If a defect in material or workmanship is found during the warranty period, KOGANEI CORP. will replace any part proved defective under normal use free of charge and will provide the service necessary to replace such a part.

Limitations

- This warranty is in lieu of all other warranties, expressed or implied, and is limited to the original cost of the product and shall not include any transportation fee, the cost of installation or any liability for direct, indirect or consequential damage or delay resulting from the defects.

- KOGANEI CORP. shall in no way be liable or responsible for injuries or damage to persons or property arising out of the use or operation of the manufacturer's product.

- This warranty shall be void if the engineered safety devices are removed, made inoperative or not periodically checked for proper functioning.

- Any operation beyond the rated capacity, any improper use or application, or any improper installation of the product, or any substitution upon it with parts not furnished or approved by KOGANEI CORP., shall void this warranty.

- This warranty covers only such items supplied by KOGANEI CORP. The products of other manufacturers are covered only by such warranties made by those original manufacturers, even though such items may have been included as the components.

The specifications are subject to change without notice.

URL <http://www.koganei.co.jp>

E-mail: overseas@koganei.co.jp



KOGANEI CORPORATION

OVERSEAS DEPARTMENT

3-11-28, Midori-cho, Koganei City, Tokyo 184-8533, Japan
Tel: 81-42-383-7271 Fax: 81-42-383-7276

KOGANEI INTERNATIONAL AMERICA, INC.

39300 Civic Center Dr., Suite 280, Fremont, CA 94538, U.S.A.
Tel: 1-510-744-1626 Fax: 1-510-744-1676

SHANGHAI KOGANEI INTERNATIONAL TRADING CORPORATION

Room 2606-2607, Tongda Venture Building No.1, Lane 600, Tianshan Road,
Shanghai, 200051, China
Tel: 86-21-6145-7313 Fax: 86-21-6145-7323

TAIWAN KOGANEI TRADING CO., LTD.

Rm. 2, 13F., No88, Sec. 2, Zhongxiao E. Rd., Zhongzheng Dist., Taipei City 100,
Taiwan (ROC)
Tel: 886-2-2393-2717 Fax: 886-2-2393-2719

KOGANEI KOREA CO., LTD.

KT&G Cosmo Bldg., 3F, 40-13, Maesanno 2-ga, Paldal-gu, Suwon-si, Gyeonggi-do,
442-847, Korea
Tel: 82-31-246-0414 Fax: 82-31-246-0415

KOGANEI (THAILAND) CO., LTD.

3300/90, Tower B, Elephant Tower, 16th Fl., Phaholyothin Road, Chomphon,
Chatuchak, Bangkok 10900, Thailand
Tel: 66-2-937-4250 Fax: 66-2-937-4254

KOGANEI ASIA PTE. LTD.

12 Arumugam road #03-12, Lion Building B, 409958, Singapore
Tel: 65-6293-4512 Fax: 65-6293-4513