

# Modular Types Achieve Maximally Rationalized Air Preparation Systems.

The Koganei Multi Series offers a wide variety of series configurations and variations, supplying optimized air for all kinds of air actuation and air controls. Moreover, the modular type enables the user to assemble individual devices into a single compact assembly for easy maintenance after mounting.

## F.R.L. Combinations 59



Model	Port size				Rc
	1/8	1/4	3/8	1/2	
<b>C150</b>	01	02			
<b>C200</b>		02			
<b>C300</b>		02	03		
<b>C400</b>		02	03		
<b>C600</b>		02	03	04	

## Filter Regulators 63

Standard, low pressure, built-in check mechanism types



Model			Port size				Rc
Standard	Low pressure	Built-in check mechanism	1/8	1/4	3/8	1/2	
<b>FR150</b>	<b>FR151</b>	<b>FR152</b>	01	02			
<b>FR300</b>	<b>FR301</b>	<b>FR302</b>		02	03		
<b>FR600</b>	<b>FR601</b>	<b>FR602</b>		02	03	04	

## Air Filters 67



Model	Port size				Rc
	1/8	1/4	3/8	1/2	
<b>F150</b>	01	02			
<b>F300</b>		02	03		
<b>F600</b>		02	03	04	

## Mist Filters 69



Model	Port size			Rc
	1/4	3/8	1/2	
<b>MF300</b>	02	03		
<b>MF400</b>	02	03	04	
<b>MF600</b>	02	03	04	

## Micro Mist Filters 71



Model	Port size			Rc
	1/4	3/8	1/2	
<b>MMF150</b>	02	03		
<b>MMF300</b>	02	03	04	
<b>MMF400</b>	02	03	04	

## Auto Drains 73



Model	Body size
<b>AD300</b>	For 300 series
<b>AD600</b>	For 600 series

## Regulators 74

Standard, low pressure, built-in check mechanism types



Model			Port size				Rc
Standard	Low pressure	Built-in check mechanism	1/8	1/4	3/8	1/2	
<b>R150</b>	<b>R151</b>	<b>R152</b>	01	02			
<b>R300</b>	<b>R301</b>	<b>R302</b>		02	03		
<b>R600</b>	<b>R601</b>	<b>R602</b>		02	03	04	

## Precision Regulator 77



Model	Port size	Rc
<b>PR200</b>	1/4	02

### High-relief Regulators 79



	Model	Port size				Rc
		1/8	1/4	3/8	1/2	
Internal pilot	<b>HR200</b>	01	02			
	<b>HR600</b>			03	04	
External pilot	<b>HRA200</b>	01	02			
	<b>HRA600</b>			03	04	

### Manifold Regulators 83

Standard, low pressure types



Model		Port size		Rc
Standard	Low pressure	1/4	3/8	
<b>MR302</b>	<b>MR303</b>	02	03	

### Lubricators 86

Standard, micro lubricator



	Model		Port size				Rc
	Standard	Micro lubricator	1/8	1/4	3/8	1/2	
	<b>L150</b>	—	01	02			
	<b>L300</b>	<b>L301</b>	02	03			
	<b>L600</b>	<b>L601</b>	02	03	04		

### Residual Pressure Exhaust Valves 89



Model	Port size				Rc
	1/8	1/4	3/8	1/2	
<b>300V</b>	01	02	03		
<b>600V</b>				04	

### Modules and Adapters 91

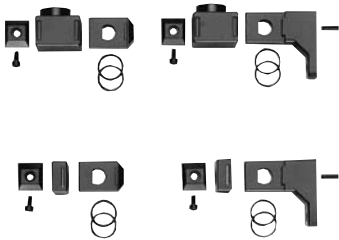

### Brackets 95



# Components Maximize the Benefits of the Modular Type.

A wide selection of accessories for system upgrades of components and their functions allows for extensive adaptability of the modular type.

## Modular System Upgrades

Use of modules and S adapters allows configuration of systems optimized for all kinds of applications and air consumption.

### F.R.L. Combinations

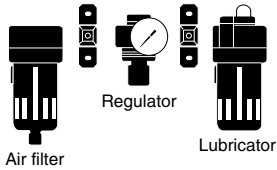

### F.R.L. Combinations

(Large capacity air filters and lubricators for easy maintenance)

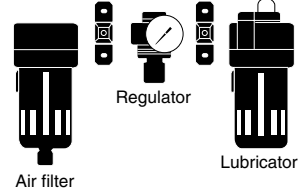

### F, MF, MMF, and R for Clean Air Applications

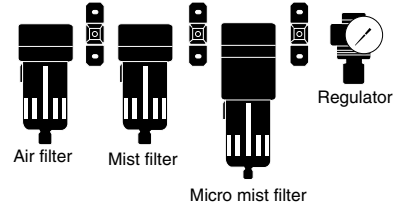

### Precision Pressure Control

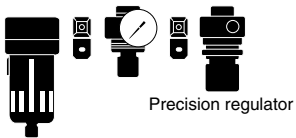

### Individual Pressure Control

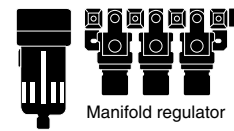

## Modules

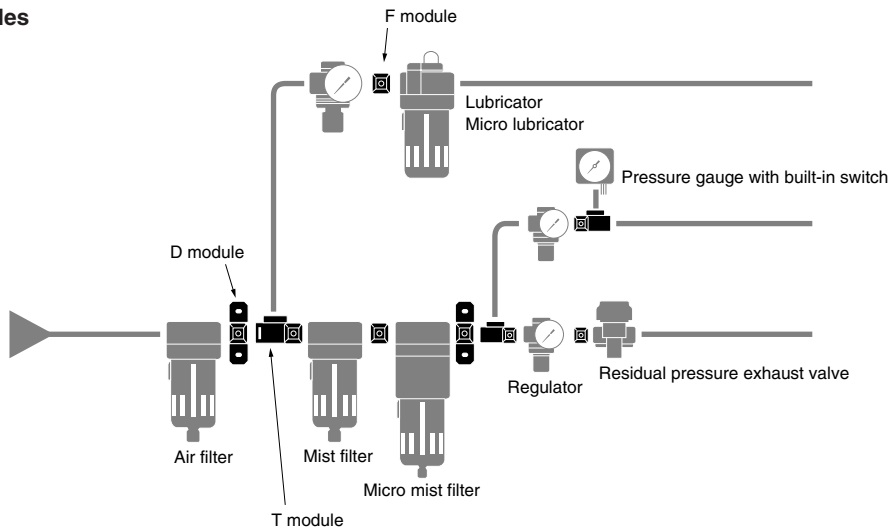

## S adapters

### Quick attaching and removal

Allows installation or removal of equipment while leaving the piping intact.

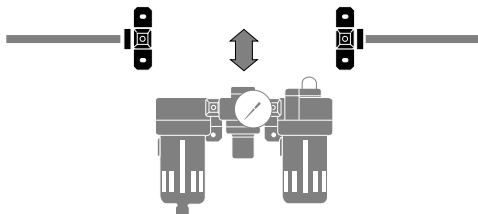

### Connect different size piping

Allows changes in the IN and OUT piping sizes.

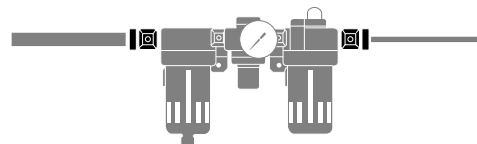

### List of Equipment Combinations

Body size		150 series					300 series							600 series											
Model		FR150	F150	R150	L150	HR200	FR300	F300	MF300	MMF150	R300	PR200 <sup>Note 2</sup>	MR300 <sup>Note 1</sup>	L300	300V	FR600	F600	MF400	MF600	MMF300	MMF400	R600	L600	600V	HR600
150 series	FR150	<b>8-15F</b> <b>8-15D</b> <b>8-15T</b> <input type="checkbox"/> <b>8-15DT</b> <input type="checkbox"/> <b>8-15S</b> <input type="checkbox"/> <b>8-15DS</b> <input type="checkbox"/>					<b>8-20D</b> (D module for bracket-combined use)																		
	F150																								
	R150																								
	L150																								
	HR200																								
300 series	FR300	<b>8-20D</b> (D module for bracket-combined use)					<b>8-30F</b> (F module) <b>8-30D</b> (D module for bracket-combined use) <b>8-30T</b> <input type="checkbox"/> (T module) <b>8-30DT</b> <input type="checkbox"/> (T module for bracket-combined use) <b>8-30S</b> <input type="checkbox"/> (S adapter) <b>8-30DS</b> <input type="checkbox"/> (S adapter for bracket-combined use)							<b>8-40D</b> (D module for bracket-combined use)											
	F300																								
	MF300																								
	MMF150																								
	R300																								
	PR200 <sup>Note 2</sup>																								
	MR300 <sup>Note 1</sup>																								
	L300																								
	300V																								
600 series	FR600						<b>8-40D</b> (D module for bracket-combined use)							<b>8-60F</b> (F module) <b>8-60D</b> (D module for bracket-combined use) <b>8-60T</b> <input type="checkbox"/> (T module) <b>8-60DT</b> <input type="checkbox"/> (T module for bracket-combined use) <b>8-60S</b> <input type="checkbox"/> (S adapter) <b>8-60DS</b> <input type="checkbox"/> (S adapter for bracket-combined use)											
	F600																								
	MF400																								
	MF600																								
	MMF300																								
	MMF400																								
	R600																								
	L600																								
	600V																								
	HR600																								

- Modules combining same-size equipment.
- Modules combining equipment of different sizes.
- Cannot be combined.

Notes: 1. Piping direction for the manifold regulator **MR300** differs from other equipment types. See p.83 for details.  
 2. The precision regulator **PR200** cannot be combined with the **600** series.

### List of Module Adapter Types

For 150, 300, and 600 series

Module and adapter Body size	F module		D module		T module		S adapter	
	F	D	T	DT	S	DS		
	(For modules only)	(For brackets only)	(Branch piping)	(Brackets for combined use with branch piping)	(Port connection)	(Brackets for combined use with port connection)		
<b>15</b> (For 150 series)	Multi series  Multi series <b>8-15F</b>	Multi series  Multi series <b>8-15D</b>	Connection port  Multi series <b>8-15T</b> <input type="checkbox"/>	Connection port  Multi series <b>8-15DT</b> <input type="checkbox"/>	Connection port  Multi series <b>8-15S</b> <input type="checkbox"/>	Connection port  Multi series <b>8-15DS</b> <input type="checkbox"/>		
<b>30</b> (For 300 series)	 <b>8-30F</b>	 <b>8-30D</b>	 <b>8-30T</b> <input type="checkbox"/>	 <b>8-30DT</b> <input type="checkbox"/>	 <b>8-30S</b> <input type="checkbox"/>	 <b>8-30DS</b> <input type="checkbox"/>		
<b>60</b> (For 600 series)	 <b>8-60F</b>	 <b>8-60D</b>	 <b>8-60T</b> <input type="checkbox"/>	 <b>8-60DT</b> <input type="checkbox"/>	 <b>8-60S</b> <input type="checkbox"/>	 <b>8-60DS</b> <input type="checkbox"/>		

### For connections between different sizes

Module Body size	D module (Brackets for combined use)
<b>20</b> (For connecting 150 and 300 series)	300 Series  150 Series <b>8-20D</b>
<b>40</b> (For connecting 300 and 600 series)	600 Series  300 Series <b>8-40D</b>

# F.R.L. COMBINATIONS

## C150, C200, C300, C400, C600

- An easy-mounting and easy-maintenance modular type.
- Many combinations of body sizes and port sizes.
- Full range of accessories and options with priority on performance.

### Symbol

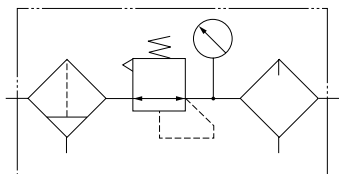

### Specifications

Item	Model	C150	C200	C300	C400	C600
Media		Air				
Port size	Rc	1/8, 1/4	1/4	1/4, 3/8	1/4, 3/8	1/4, 3/8, 1/2
Filtration rating	$\mu\text{m}$	5				
Pressure setting range	MPa [psi.]	0.05~0.83 [7~120]				
Maximum operating pressure	MPa [psi.]	0.93 [135]				
Proof pressure	MPa [psi.]	1.47 [213]				
Operating temperature range (atmosphere and media)	$^{\circ}\text{C}$ [ $^{\circ}\text{F}$ ]	5~60 [41~140]				
Air filter drain capacity	cc [in. <sup>3</sup> ]	15 [0.92]	55 [3.36]		90 [5.49]	
Oil capacity for lubricator	cc [in. <sup>3</sup> ]	25 [1.53]	85 [5.19]		160 [9.76]	
Recommended lubrication		Turbine oil Class 1 [ISO VG32] or equivalents.				
Mass (with pressure gauge)	kg [lb]	Standard	1.16 [2.56]	1.20 [2.65]	1.43 [3.15]	1.51 [3.33]
		Auto drain type	1.19 [2.62]	1.23 [2.71]	1.46 [3.22]	1.54 [3.40]
Materials	Body	Aluminum die-casting	Aluminum die-casting Zinc die-casting	Zinc die-casting	Aluminum die-casting Zinc die-casting	Aluminum die-casting
	Bowl	Polycarbonate				
Models of components	Air filter	F150	F300	F300	F600	F600
	Regulator	R150	R150	R300	R300	R600
	Lubricator	L150	L300	L300	L600	L600
Standard attachments	Bracket	D module				
	Air filter	Push type drain cock	Screw type drain cock, bowl guard			
	Regulator	Pressure gauge G1-40 ( $\phi$ 40 $\times$ 1MPa [145psi.])				
	Lubricator	—	Bowl guard			

Note: Figure in parentheses ( ) shows mass with bowl guard.

### Order Codes

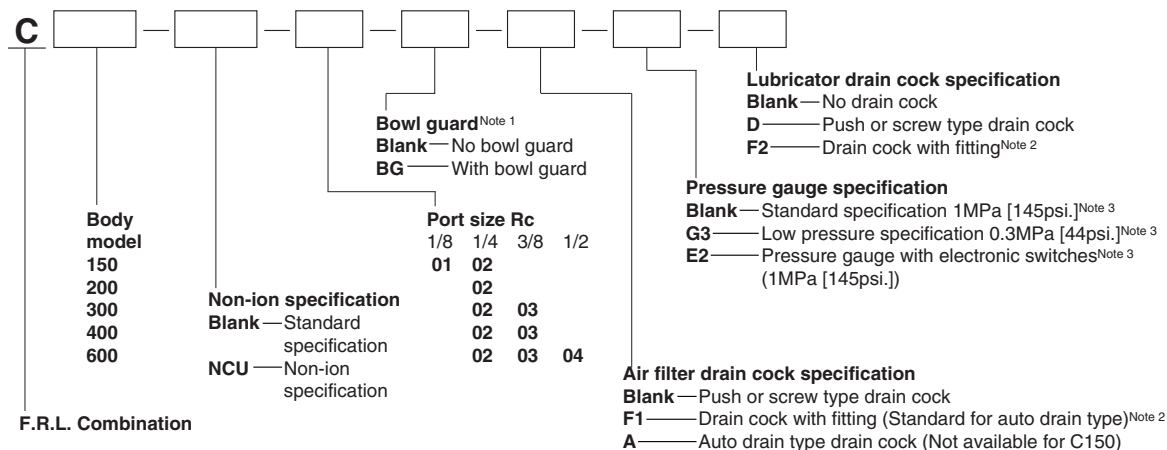

Notes: 1. For C150 only. Standard for all models other than C150.  
2. Available only for C150 with -BG (bowl guard).  
3. For the specifications and dimensions for the pressure gauge, and pressure gauge with electronic switches, see p.172 and 177~181.

# Inner Construction

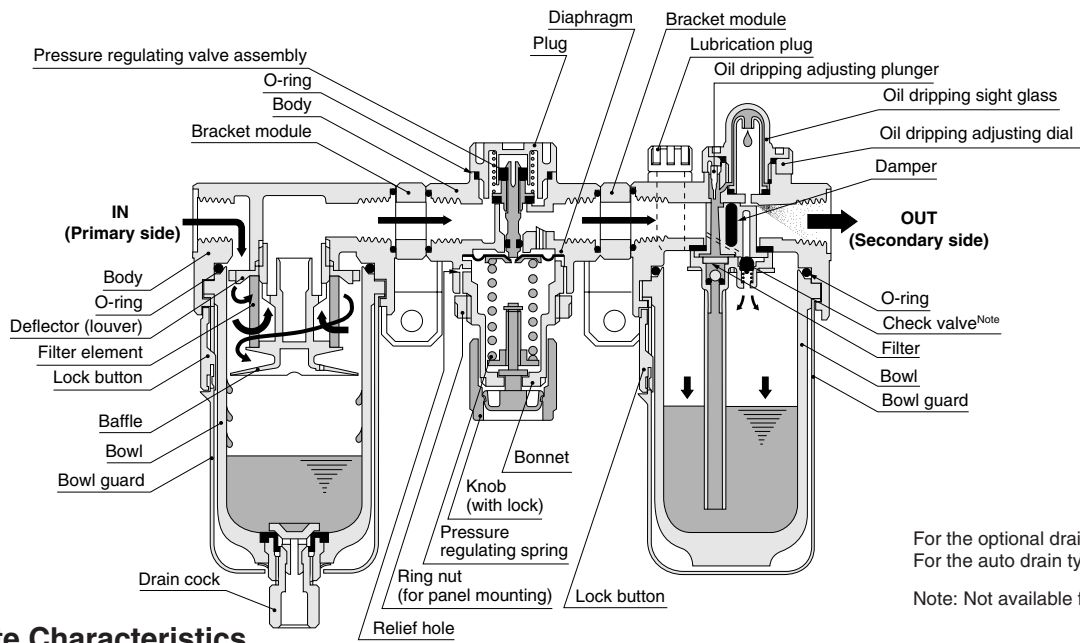

## Flow Rate Characteristics

**C150**

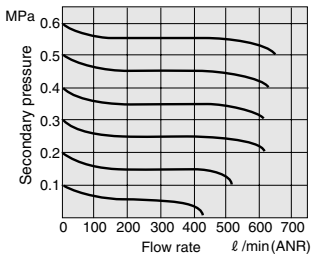

**C200**

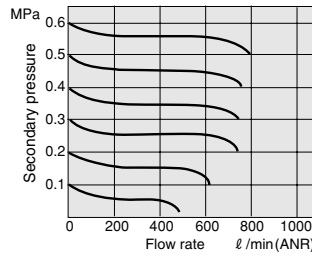

**C300**

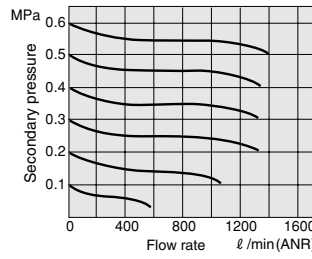

**C400**

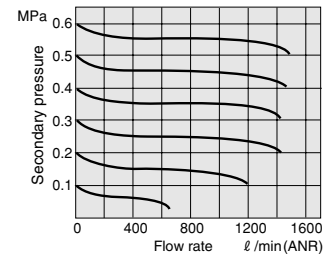

**C600**

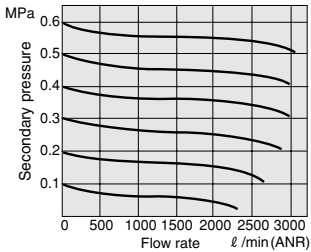

Remark: Graphs show flow rate characteristics when the primary pressure is fixed at 0.7MPa [102psi].

1MPa=145psi. 1 ℓ/min=0.0353ft<sup>3</sup>/min.

## Pressure Characteristics

**C150**

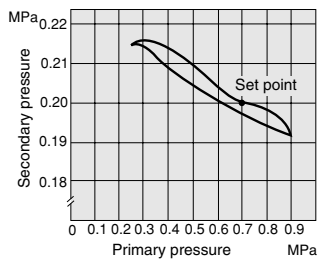

**C200**

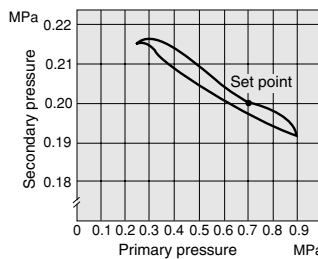

**C300**

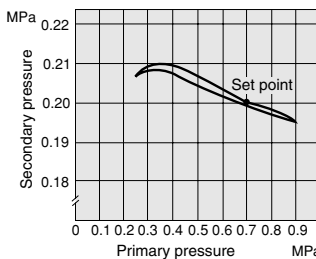

**C400**

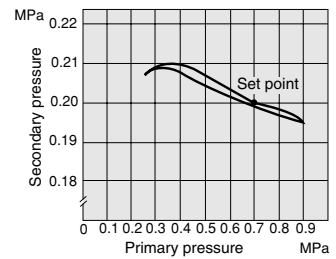

**C600**

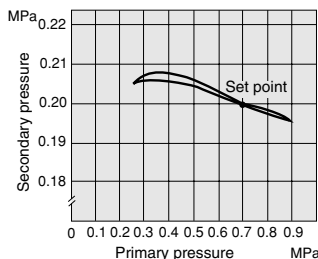

1MPa=145psi. 1 ℓ/min=0.0353ft<sup>3</sup>/min.

# Dimensions of F.R.L. Combinations (mm)

## C150

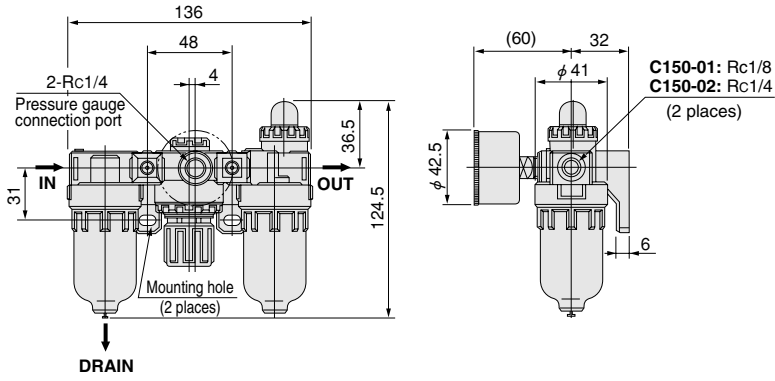

### Drain cock option

- Push type with fitting  
(Air filter: -BG-F1)  
(Lubricator: -BG-F2)

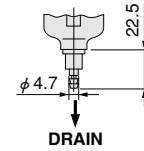

- Push type  
(Air filter: Standard)  
(Lubricator: -D)

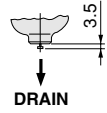

## C200

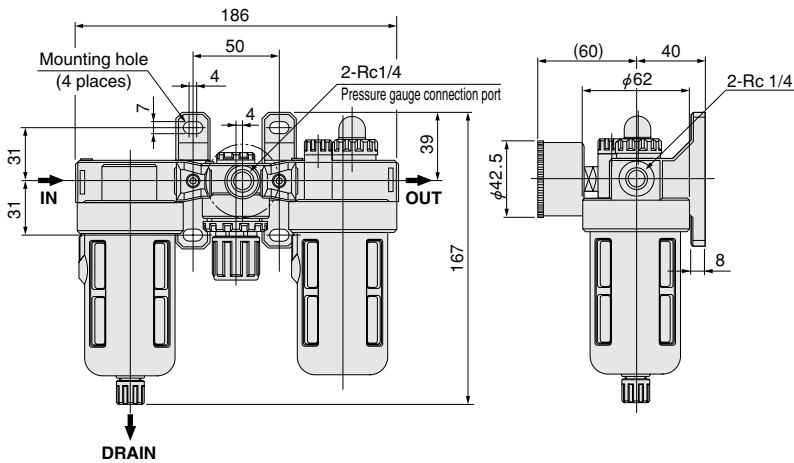

### Drain cock option

- Screw type with fitting  
(Air filter: -F1)  
(Lubricator: -F2)
- Auto drain type  
(Air filter: -A)

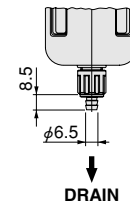

- Screw type  
(Air filter: Standard)  
(Lubricator: -D)

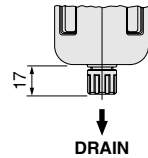

## C300

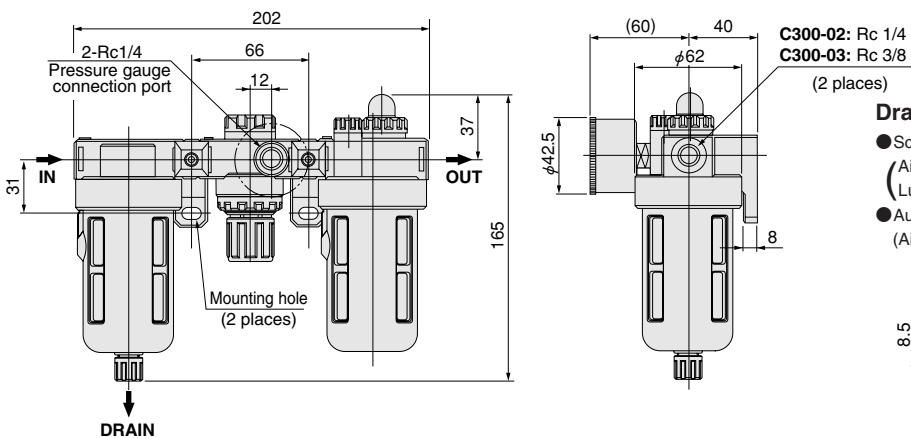

### Drain cock option

- Screw type with fitting  
(Air filter: -F1)  
(Lubricator: -F2)
- Auto drain type  
(Air filter: -A)

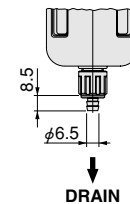

- Screw type  
(Air filter: Standard)  
(Lubricator: -D)

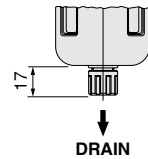

### C400

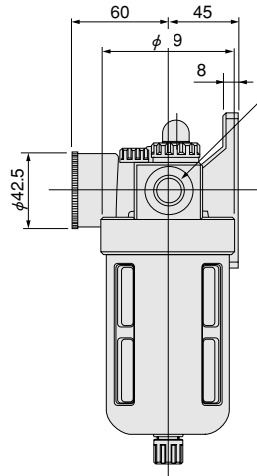
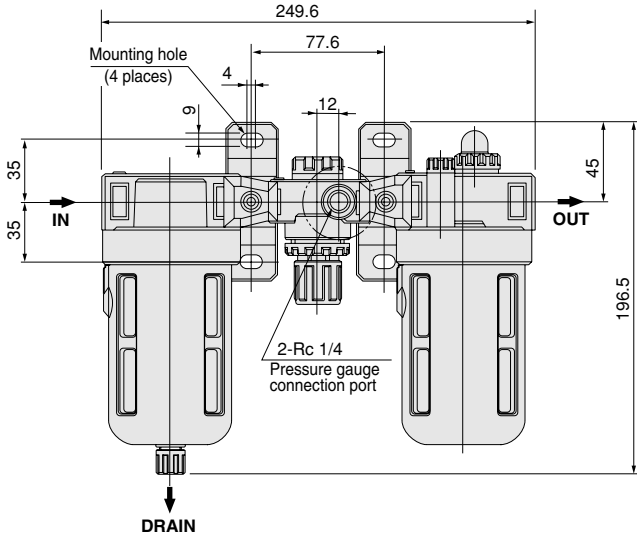

C400-02: Rc 1/4  
C400-03: Rc 3/8  
(2 places)

#### Drain cock option

- Screw type with fitting  
(Air filter: -F1)  
(Lubricator: -F2)
- Auto drain type  
(Air filter: -A)

- Screw type  
(Air filter: Standard)  
(Lubricator: -D)

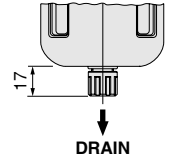
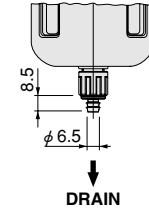

### C600

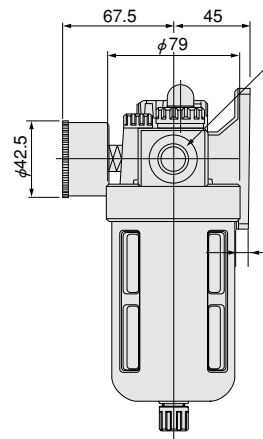
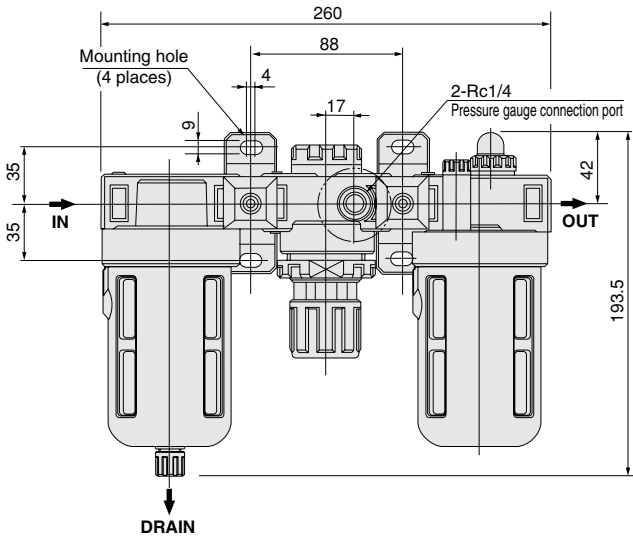

C600-02: Rc 1/4  
C600-03: Rc 3/8  
C600-04: Rc 1/2  
(2 places)

#### Drain cock option

- Screw type with fitting  
(Air filter: -F1)  
(Lubricator: -F2)
- Auto drain type  
(Air filter: -A)

- Screw type  
(Air filter: Standard)  
(Lubricator: -D)

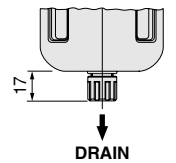
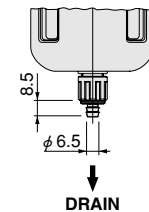

#### Option

- Pressure gauge with electronic switches: -E2

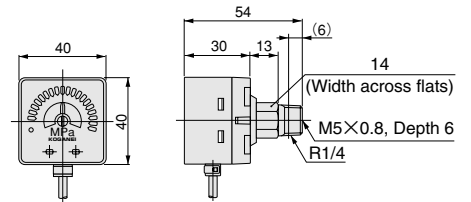



# MODULES AND ADAPTERS



- F module is a connector facilitating combinations of Multi Series equipment of the same body size.
- D module offers a mounting bracket function.
- T module provides branch piping at desired locations.
- S adapter allows easy installation and removal of equipment without disturbing the piping.
- Standard can be used as NCU specification.

## Model List

### For 150, 300 and 600 series

Module, adapter Body size	F module (For modules only)	D module (Brackets for combined use)	T module (Branch piping)		S adapter (Port connection)	
	<b>F</b> Multi Series 8-15F	<b>D</b> Multi Series 8-15D	<b>T</b> Connection port 8-15T	<b>DT</b> Connection port 8-15DT	<b>S</b> Connection port 8-15S	<b>DS</b> Connection port 8-15DS
15 (For 150 series)						
30 (For 300 series)						
60 (For 600 series)						

### For connections between different sizes

Module Body size	D module (Brackets for combined use)
20 (For connecting 150 and 300 series)	For 300 series 8-20D For 150 series
40 (For connecting 300 and 600 series)	For 600 series 8-40D For 300 series

Remark: Material is zinc die-casting.

## Order Codes



- Module and adapter**
- F — F module
  - D — D module for bracket-combined use
  - T — T module
  - DT — T module for bracket-combined use
  - S — S adapter
  - DS — S adapter for bracket-combined use

### Body size

- 15 — For 150 series, HR200 and HRA200
- 20 — For connecting 150 and 300 series<sup>Note 1</sup>
- 30 — For 300 series
- 40 — For connecting 300 and 600 series<sup>Note 1</sup>
- 60 — For 600 series, HR600 and HRA600

Port size <sup>Note 2</sup>	Rc		Applicable body size
	1/8	1/4	
1	2	1/2	150
2	3		300
2 <sup>Note 3</sup>	3	4	600

- Notes: 1. Used only with D module.  
2. Not available in F module or D module.  
3. Used only with S adapter and DS adapter.

For details about equipment combinations, see p.58.

## Dimensions of F Modules (mm)

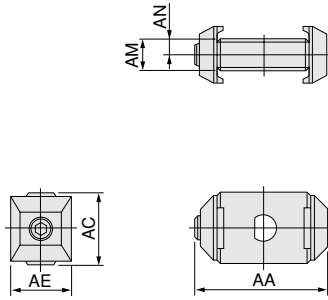

Type Code	AA	AC	AE	AM	AN	Mass g
<b>8-15F</b>	36	20	17.4	8	4	38
<b>8-30F</b>	42	24	19.4	10	5	63
<b>8-60F</b>	56.5	30	31	12	6	150

Note: When assembling with other equipment, add the AM dimensions to the total.

## Dimensions of D Modules (mm)

**8-15D**  
**8-30D**

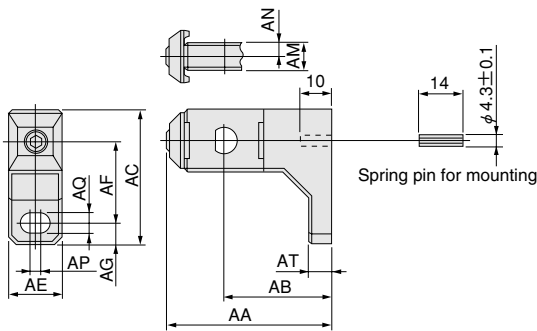

Model Code	AA	AB	AC	AE	AF	AG	AM	AN	AP
<b>8-15D</b>	50.5	32	49	17.4	31	8	8	4	4
<b>8-30D</b>	61.5	40	50.5	19.4	31	8	10	5	4

Model Code	AQ	AT	Mass g
<b>8-15D</b>	7	6	84
<b>8-30D</b>	7	8	137

Note: When assembling with other equipment, add the AM dimensions to the total.

**8-20D**  
**8-40D**

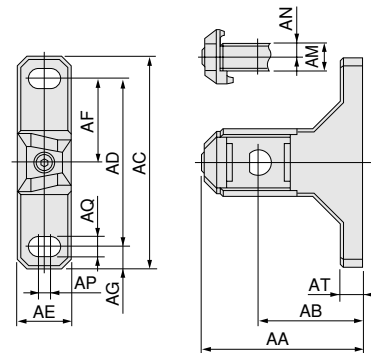

Model Code	AA	AB	AC	AD	AE	AF	AG	AM	AN	AP
<b>8-20D</b>	61.5	40	78	62	19.4	31	8	10	5	4
<b>8-40D</b>	74	45	90	70	31	35	10	16.8	6	4

Model Code	AQ	AT	Mass g
<b>8-20D</b>	7	8	141
<b>8-40D</b>	9	8	300

Note: When assembling with other equipment, add the AM dimensions to the total.

**8-60D**

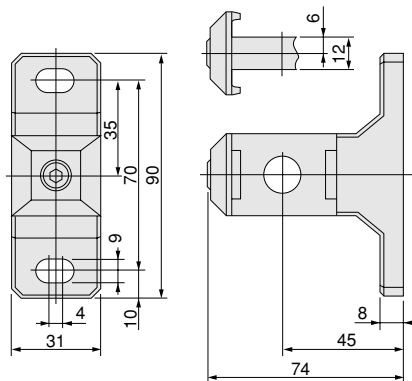

Mass: 260 g

Note: When assembling with other equipment, add 12mm to the total.

# Dimensions of T Modules (mm)

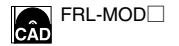

- 8-15T
- 8-30T
- 8-60T

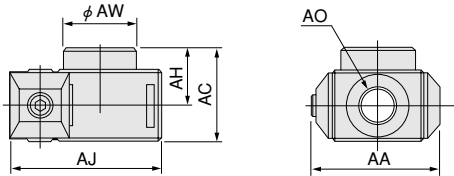
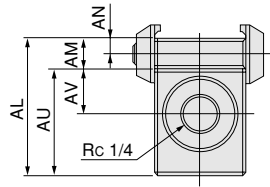

Model Code	AA	AC	AH	AJ	AL	AM	AN	AO	AU	AV	AW	Mass g
8-15T1	36	27	17	43.5	39	8	4	Rc1/8	31	13	20	116
8-15T2	36	27	17	43.5	39	8	4	Rc1/4	31	13	20	110
8-30T2	42	31	19	49.5	45	10	5	Rc1/4	35	15	24	196
8-30T3	42	31	19	49.5	45	10	5	Rc3/8	35	15	24	181
8-60T3	56.5	40	24	66.5	57	12	6	Rc3/8	45	19	32	271
8-60T4	56.5	40	24	66.5	57	12	6	Rc1/2	45	19	32	264

Note: When assembling with other equipment, add the AL dimensions to the total.

- 8-15DT
- 8-30DT

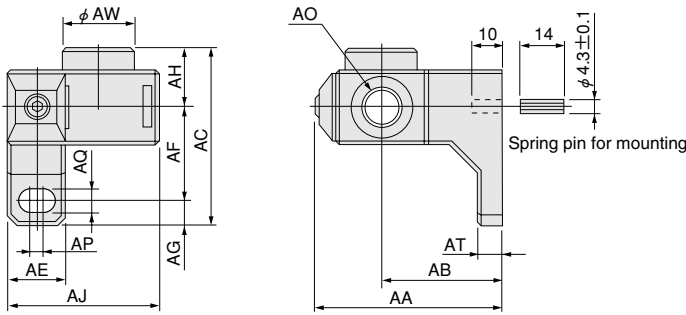
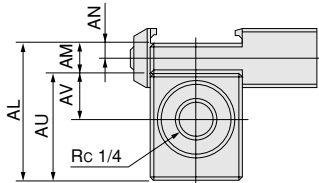

Model Code	AA	AB	AC	AE	AF	AG	AH	AJ	AL
8-15DT1	50.5	32	56	17.4	31	8	17	44	39
8-15DT2	50.5	32	56	17.4	31	8	17	44	39
8-30DT2	61.5	40	58	19.4	31	8	19	50	45
8-30DT3	61.5	40	58	19.4	31	8	19	50	45

Model Code	AM	AN	AO	AP	AQ	AT	AU	AV	AW
8-15DT1	8	4	Rc1/8	4	7	6	31	13	20
8-15DT2	8	4	Rc1/4	4	7	6	31	13	20
8-30DT2	10	5	Rc1/4	4	7	8	35	15	24
8-30DT3	10	5	Rc3/8	4	7	8	35	15	24

Model Code	Mass g
8-15DT1	161
8-15DT2	155
8-30DT2	273
8-30DT3	257

Note: When assembling with other equipment, add the AL dimensions to the total.

- 8-60DT

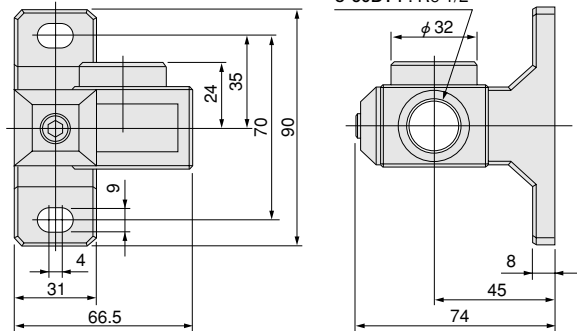
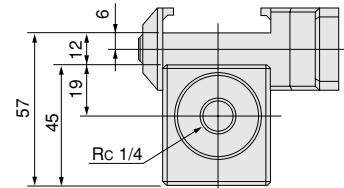

Mass  
 8-60DT3: 385g  
 8-60DT4: 375g

Note: When assembling with other equipment, add 57mm to the total.

# Dimensions of S Adapters (mm)



- 8-15S
- 8-30S
- 8-60S

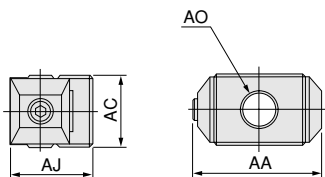
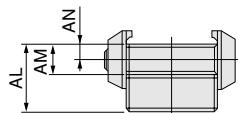

Model	Code	AA	AC	AJ	AL	AM	AN	AO	Mass g
8-15S1		36	20	24.5	20	8	4	Rc1/8	51
8-15S2		36	20	24.5	20	8	4	Rc1/4	49
8-30S2		42	24	26.5	22	10	5	Rc1/4	81
8-30S3		42	24	26.5	22	10	5	Rc3/8	78
8-60S2		56.5	32	37.5	28	12	6	Rc1/4	190
8-60S3		56.5	32	37.5	28	12	6	Rc3/8	187
8-60S4		56.5	32	37.5	28	12	6	Rc1/2	183

Note: When assembling with other equipment, add the AL dimensions to the total.

- 8-15DS
- 8-30DS

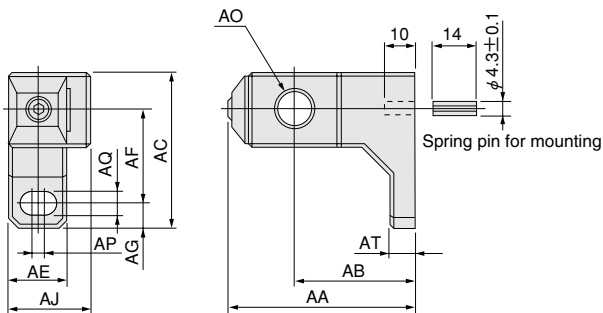
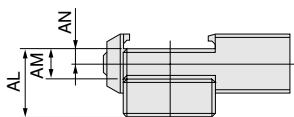

Model	Code	AA	AB	AC	AE	AF	AG	AJ	AL	AM	AN	AO	AP	AQ	AT
8-15DS1		50.5	32	49	18	31	8	25	20	8	4	Rc1/8	4	7	6
8-15DS2		50.5	32	49	18	31	8	25	20	8	4	Rc1/4	4	7	6
8-30DS2		61.5	40	51	20	31	8	27	22	10	5	Rc1/4	4	7	8
8-30DS3		61.5	40	51	20	31	8	27	22	10	5	Rc3/8	4	7	8

Model	Code	Mass g
8-15DS1		96
8-15DS2		94
8-30DS2		155
8-30DS3		150

Note: When assembling with other equipment, add the AL dimensions to the total.

## 8-60DS

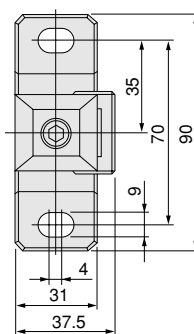
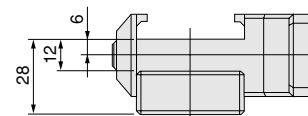

8-60DS2 : Rc 1/4  
8-60DS3 : Rc 3/8  
8-60DS4 : Rc 1/2

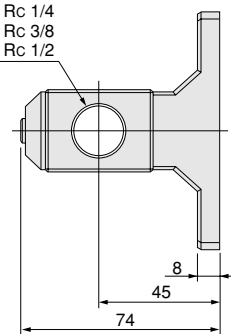

Mass  
8-60DS2: 302g  
8-60DS3: 299g  
8-60DS4: 295g

Note: When assembling with other equipment, add 28mm to the total.

# BRACKETS



## Bracket Models and Applicable Components

Components type		Bracket model	Remark
F.R.L. combinations	C150	<b>8-15D</b>	D module for bracket-combined use, standard equipment
	C200	<b>8-20D</b>	
	C300	<b>8-30D</b>	
	C400	<b>8-40D</b>	
	C600	<b>8-60D</b>	
Filter regulators	FR150	<b>8-15 (8-15A)</b>	Standard equipment
	FR300	<b>8-30 (8-30A, 8-60B)</b> <sup>Note2</sup>	
	FR600	<b>8-65 (8-60B)</b> <sup>Note2</sup>	
Air filters	F150	<b>8-15A</b>	Body supporting type, optional
	F300	<b>8-30A (8-60B)</b> <sup>Note2</sup>	Piping supporting type, optional
	F600	<b>8-60B</b>	Piping supporting type, optional
Mist filters	MF300	<b>8-30A (8-60B)</b> <sup>Note2</sup>	Body supporting type, optional
	MF400	<b>8-60B</b> <sup>Note2</sup>	Piping supporting type, optional
	MF600		
Micro mist filters	MMF150	<b>8-30A (8-60B)</b> <sup>Note2</sup>	Body supporting type, optional
	MMF300	<b>8-60B</b> <sup>Note2</sup>	Piping supporting type, optional
	MMF400		
Regulators	R150	<b>8-15</b>	Standard equipment
	R300	<b>8-30 (8-60B)</b> <sup>Note2</sup>	
	R600	<b>8-65 (8-60B)</b> <sup>Note2</sup>	
Precision regulator	PR200	<b>8-21Z</b>	Body supporting type, optional
High-relief regulators	HR200	<b>8-22Z</b>	Body supporting type, optional
	HR600		
	HRA200		
	HRA600		
Manifold regulators	MR300	<b>8-30D</b>	D module for bracket-combined use, optional
Lubricators	L150	<b>8-15A</b>	Body supporting type, optional
	L300	<b>8-30A (8-60B)</b> <sup>Note2</sup>	Piping supporting type, optional
	L600	<b>8-60B</b> <sup>Note2</sup>	
Residual pressure exhaust valves	300V	<b>8-31C</b>	Body supporting type, optional
	600V		

Notes: 1. Models in parentheses ( ) are non-standard, but are acceptable for use.  
 2. Pipe supporting type brackets (8-60B) are sold in a set of two brackets.

# Dimensions of Brackets (mm)



## For Filter Regulator and Regulator

### 8-15

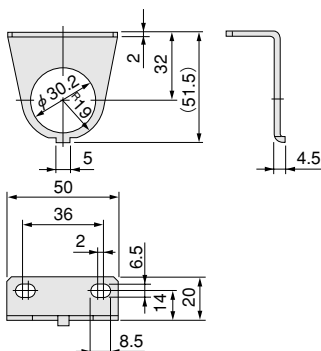

Mass: 31g

### 8-30

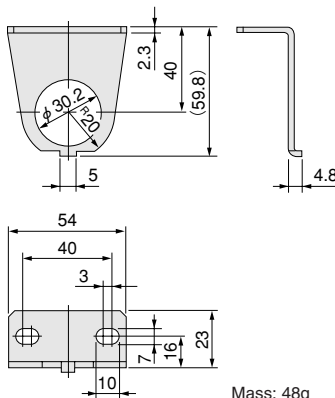

Mass: 48g

### 8-65

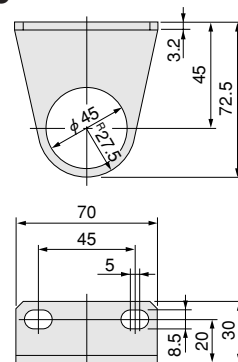

Mass: 69g

## For Air Filter, Mist Filter, Micro Mist Filter, and Lubricator

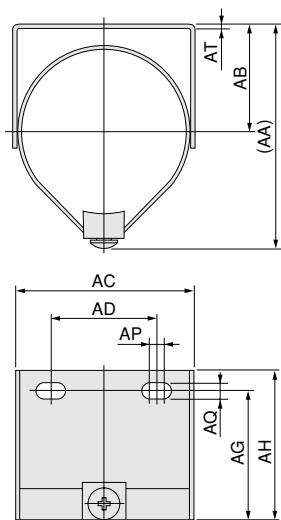

Mass  
8-15A: 60g  
8-30A: 80g

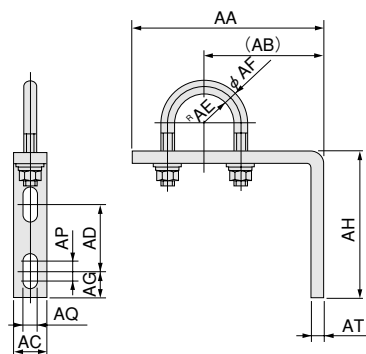

Mass: 107g

Model	Code	AA	AB	AC	AD	AG	AH	AP	AQ	AT
8-15A		64	32	46	32	50	56	2	6.4	1.2
8-30A		84	40	66.8	40	48	56	5	6.4	1.2

Model	Code	AA	AB	AC	AD	AE	AF	AG	AH	AP	AQ	AT
8-60B		72	45	12	25	11	5	10	55	7	5.5	4.5

Note: Pipe supporting type brackets (8-60B) are sold in a set of two brackets.

## For Precision Regulator

### 8-21Z

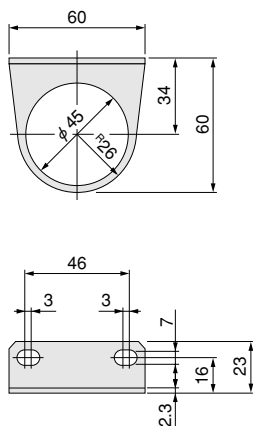

Mass: 42g

## For High-relief Regulator

### 8-22Z

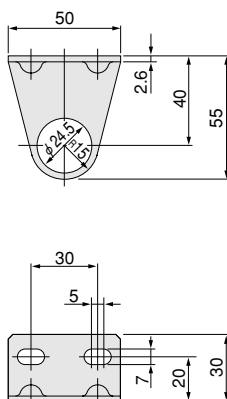

Mass: 52g

## For Residual Pressure Exhaust Valve

### 8-31C

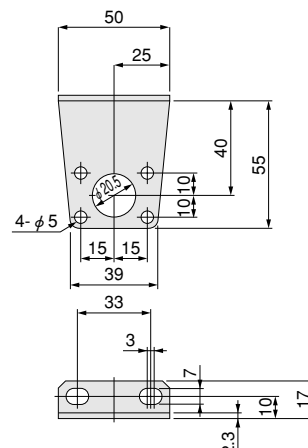

Mass: 50g

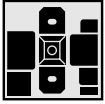

## Module

### Installation

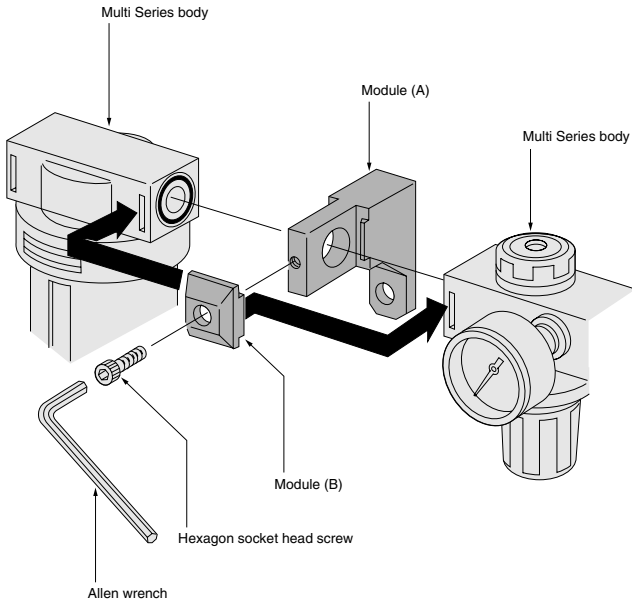

1. On all Multi Series equipment, the side displaying an arrow mark on the top of the body indicates the IN port (primary side).
2. Align convex section of modules (A) and (B) in the grooves of the Multi Series body, and use a hexagon socket head screw to tighten and secure them in place.

- Cautions:**
1. For the module types applicable to each Multi Series type, see p.91.
  2. The Multi Series modules should not be allowed to sag when mounted. As there is a possibility that they will sag under the weight of connections of steel piping or other heavy piping, always connect module brackets to both ends of the modules before mounting.
  3. There is only one mounting hole when mounting a module using one of either 8-15D or 8-30D onto a mechanical device, causing an unstable installation. Use the spring pin supplied to prevent the unit from rotating. The pin hole here is  $\phi 4.6$  with a depth of 6.
  4. Assemble the T module so that the piping port faces upward.

### [Mounting example]

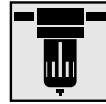
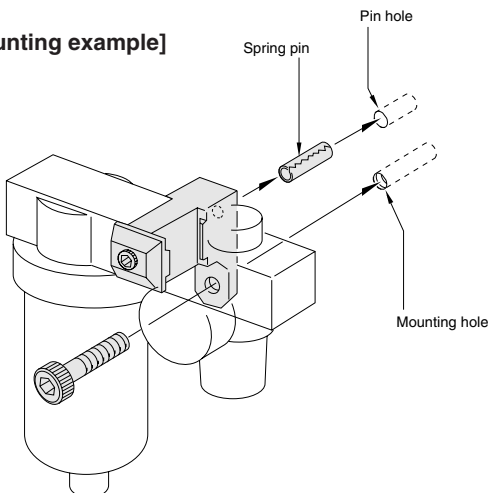

## Filter Regulator, Filter, and Lubricator

### Mounting and piping

Mount in a vertical position, with the piping connections on the top and the drain port on the bottom.

### Bowl

Because the bowl is made of polycarbonate, avoid subjecting it to excessive force or shocks. Also, do not use it in atmospheres subject to organic solvents, etc.

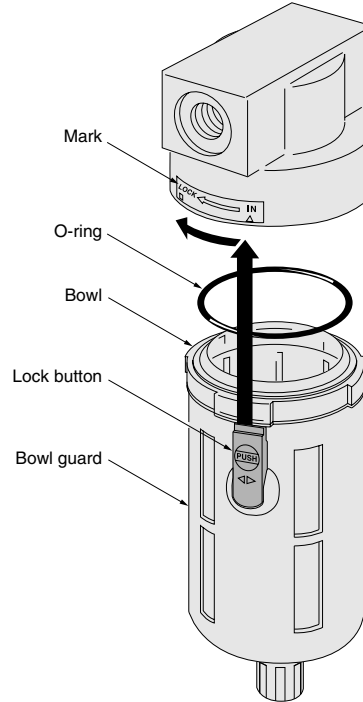

### ● Removing the bowl

While pushing down on the red lock button, rotate the bowl and bowl guard to the right (the direction opposite to the arrow mark) until it is aligned to the IN mark, then remove the bowl and bowl guard from the body.

### ● Mounting the bowl

1. Align the bowl and bowl guard to the convex section along their rims, and set the bowl into the bowl guard.
2. Align the lock button to the IN mark, and insert into the body. While pressing the bowl against the body, rotate it to the left (the direction shown by the arrow mark) until it reaches the LOCK position, and secure in place.

- Cautions:**
1. Always shut off the media before removing or mounting the bowl.
  2. Set the O-ring onto the body, and then mount the bowl and bowl guard.
  3. The bowl for the 150 series is a screw-in type. For removal or mounting, manually rotate the bowl or bowl guard.
  4. Use a neutral detergent to clean the bowl.

### Filter

1. Drain the collected liquid from the air filter on a periodic basis.
2. To clean the air filter element, remove the element and blow it off with compressed air, etc.

**Drain cock**

● **Push type**

**150 series**

(Air filter Standard  
Lubricator Order code: **-D**)

Pressing the button opens the drain port, and the collected liquid is expelled.

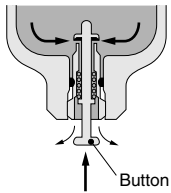

● **Push type with fitting**

**150 series**

(Air filter Order code: **-BG-F1**  
Lubricator Order code: **-BG-F2**)

Pushing the fitting upward opens the drain port, and the collected liquid is expelled.

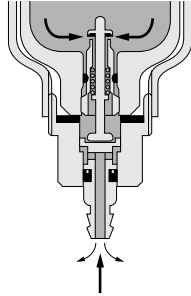

● **Screw type**

**300-600 series**

(Air filter Standard  
Lubricator Order code: **-D**)

Rotating the drain knob to the left opens the drain port, and the collected liquid is expelled.

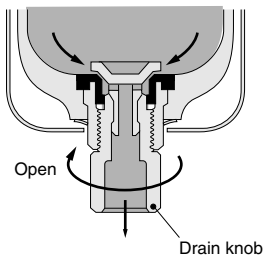

● **Screw type with fitting**

**300-600 series**

(Air filter Order code: **-F1**  
Lubricator Order code: **-F2**)

Rotating the drain knob to the left opens the drain port, and the collected liquid is expelled.

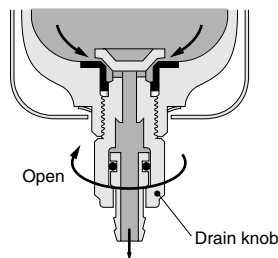

**Caution:** The drain knob should be operated using the fingertips.

● **Auto drain type**

**300-600 series**

(Air filter Order code: **-A**)

When a certain volume of collected liquid has accumulated, or when the pressure inside the bowl has fallen to less than 0.02MPa [3psi.], the collected liquid is automatically expelled. The collected liquid may also be expelled manually by turning the drain knob to the left.

**Cautions:** 1. In the auto drain, air is exhausted from the drain port until the supply pressure reaches 0.15MPa [22psi.]. This is normal, and even rotating the drain knob in this situation will not prevent the air from bleeding out.

(If the time required for the supply pressure to rise to 0.15MPa [22psi.] seems too long, consult us.)

2. The drain knob should be operated using the fingertips.
3. If attaching a tube to the fitting, use a nylon tube with inner diameter of 6mm. Do not let the tube bend in the area near the fitting connection.
4. The fitting can be rotated freely in any direction. As a result, the tube does not need to be removed even when manually draining the collected liquid.

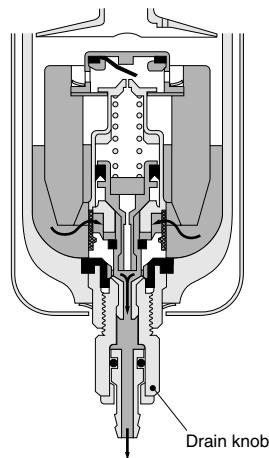

**Lubrication**

1. Use Turbine Oil Class 1 (ISO VG32) or an equivalent for lubrication. Avoid using spindle oil or machine oil.
2. For lubrication, use an Allen wrench to remove the plug from the lubrication port, and supply oil until the bowl is 80% filled.

**Caution:** Even though lubrication can be carried while supplying compressed air for the L300 and L600, lubrication cannot be carried while supplying compressed air for the L150.

**Oil drip-rate adjustment**

Rotating the lubricator dial to the left increases the oil drip-rate. Use the adjustment marks on the body and the numbers on the dial to adjust the oil drip-rate.

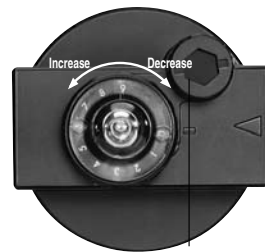

- Cautions:** 1. While the dial can be rotated continuously to the right, the rate of change for the oil dripping volume does not correspond to the numbers on the dial.
2. The numbers on the dial represent rough oil drip-rate, not the number of droplets.



# Handling Instructions and Precautions



## Filter Regulator, Regulator, Precision Regulator, Manifold Regulator, and High-relief Regulator

### Mounting and piping

#### ● General overview for regulators

In regulator configurations (with the exception of types with built-in check mechanism), the OUT port (secondary) pressure may not be exhausted to the IN port (primary) side even when the IN port pressure is 0MPa. To ensure that exhaust is performed, either use a type with built-in check mechanism, or install a check valve alongside. If a regulator with built-in check mechanism installed after the solenoid valve for cylinder pressure adjustment performed, make sure that cylinder back pressure does not cause secondary pressure on the regulator with built-in check mechanism to rise above the set pressure. The check mechanism may not operate correctly. (As a guide, use at a pressure differential between the push and pull sides of 0.3MPa or less.)

Also, because regulator (with the exception of the High-relief Regulator) relief ports are smaller than the diameter of the piping port, they may not be able to respond to sudden increases in pressure on the OUT port (secondary) side. For situations where pressures can rise sharply due to a force being applied to the cylinder externally, either use a High-relief Regulator or set the relief valve to OUT.

#### ● Precision Regulator

1. If mounting the Precision Regulator as a single unit, use a bracket (optional). A ring nut for panel mounting can also be used.
2. When piping to the Precision Regulator, position the piping so that the air supply side connects to the IN port and the actuator side connects to the OUT port. To prevent the fitting on the OUT port side from interfering with the damper tube, use piping with inner diameter at least 3mm [0.12in.] or more.



- Cautions:**
1. The regulator cannot be used with the IN port and the OUT port in the opposite positions.
  2. When mounting a fitting on the OUT port, be careful to avoid damaging the damper tube. In addition, avoid using a plug or a fitting with too small inner diameter in the OUT port. Bending the damper tube or blocking the hole could damage the precision regulator function, preventing accurate regulating pressure.
  3. Avoid a mounting position that blocks the relief hole. Blocking the relief hole could prevent regulating pressure.

#### ● Manifold Regulator

1. Use sufficiently large IN port piping, and supply via the IN ports at both manifold ends as much as possible. Moreover, when using five or more units on a manifold, mount a T module somewhere in the middle of the units, and supply via the IN ports in at least three different locations.
2. To stabilize secondary pressure, ensure a sufficiently large pressure differential (0.3MPa [44psi.] MIN.) between the IN port pressure and OUT port pressure.

#### ● High-relief Regulator

1. The High-relief Regulator's IN port (primary side) is on the top surface of the body, where the arrow ► mark is located.
2. The High-relief Regulator can be mounted as a module with any equipment in the air preparation Multi Series. Module formation and equipment compatibility for HR200 and HRA200 is the same as the 150 series, and for HR600 and HRA600, the same as the 600 series.
3. For single unit mounting, use brackets (order code :-B). A ring nut for panel mounting can also be used.
4. When mounting a pressure gauge, never grab the pressure gauge body for tightening. Always use a wrench on the square section around the connection port to tighten.
5. When mounting a muffler or exhaust filter on the EXH port, use the following table to select the type.

Model	Recommended muffler, exhaust filter
HR200 HRA200	KM-22, KM-23 EF300, EF600, EF800
HR600 HRA600	KM-31 EF300, EF600, EF800

For details, see p.549 and 552.

6. While any mounting direction is acceptable, mounting with the EXH port pointing straight up could result in noisy operation. In this case, change the pressure setting, increase the exhaust volume, or perform some other preventive measures.
7. If using a mounting ring to mount the regulator, use a mounting torque of 980.7N·cm [86.7in·lbf] or less.

- Cautions:**
1. Avoid operating methods that involve setting a valve on the primary side of the High-relief Regulator and repeatedly switching the primary pressure.
  2. If mounting a muffler, etc., on the EXH port, use a tightening torque for HR200 and HRA200 of 294.2N·cm [26.0in·lbf] or less, and for HR600 and HRA600, 490.3N·cm [43.4in·lbf] or less. When mounting, always use a wrench on the hexagonal section of the exhaust plug. Avoid using steel piping to connect the EXH port.
  3. In the external pilot type, exhausting primary pressure while supplying pilot air could cause damage to the diaphragm. For this reason, exhaust the primary side of the regulator that controls pilot pressure, and the primary side of the external pilot type at the same time.

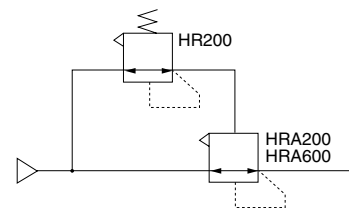

4. To avoid interfering with the piping volume, select a regulator with a large relief flow rate for the pilot regulator to be used for the external pilot type. In addition, do not allow the pilot air piping length to exceed the values shown in the table below.

O.D × I. D.mm [in.]	Piping length m [ft.]
4×2 [0.157×0.079]	2 [6.6]
6×4 [0.236×0.157]	20 [65.6]
8×6 [0.315×0.236]	50 [164]

### Pressure regulation

**Caution:** Perform the setting while checking the primary pressure and secondary pressure gauge displays. Rotating the knob too far could cause damage to the internal parts. Be particularly careful not to rotate it too far during depressurization, since time is required for relief.

#### ● Filter Regulator, Regulator, Manifold Regulator

Perform pressure regulation by pulling out the knob firmly. Rotating it to the right (clockwise direction) increases the pressure, and rotating to the left (counterclockwise direction) reduces the pressure. After regulating pressure, push the knob back into the body and lock it in place.

- Cautions:**
1. Do not attempt to rotate the knob while in the locked position.
  2. In the FR150 and R150 series, vibration noise can occur when the pressure differential between the primary pressure and setting pressure is large (0.7MPa [102psi.] or more). In this situation, reduce the pressure differential (0.5MPa [73psi.] or less).

#### ● Precision Regulator, High-relief Regulator

Perform regulating pressure by pulling out the knob firmly. Rotating it to the right (clockwise direction) increases the pressure, and rotating to the left (counterclockwise direction) reduces the pressure. After regulating pressure, push the knob back into the body and lock it in place.



**Remark:** When regulating pressure, connect a pressure gauge of a class JIS 1.5 or equivalent to the Precision Regulator's pressure gauge connection port (Rc1/4).

- Cautions:**
1. To maintain accurate pressure adjustment conditions while locked, the Precision Regulator knob includes a free (neutral) state between the lock state and pressure adjustment state. To switch between the regulating pressure and lock states, pull the knob firmly out or push it in until a clicking sound shows that it has firmly arrived in the lock state or pressure adjustment state.
  2. The Precision Regulator is a bleed type, which means that a slight amount of air constantly bleeds out of the bleed hole while the secondary side is undergoing pressure adjustment. This is a normal situation.
  3. The internal pilot type uses a metal contact seal on the pilot regulator portion that causes it to bleed a slight amount of air. This is a normal situation.

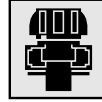

### Residual Pressure Exhaust Valve

#### Mounting and piping

1. When mounting the Residual Pressure Exhaust Valve as a single unit, use either a mounting thread on the R port side or a bracket (optional). If using steel piping, the piping itself can serve as a support.
2. Connect the piping for the Residual Pressure Exhaust Valve so that the P port is on the primary (media) side and the A port is on the mechanical device side. If using as a 2-port valve, use a Rc1/4 plug to block the R port.

- Cautions:**
1. The unit cannot be used with the P port and A port in reversed positions.
  2. If using in locations subject to dripping water, dripping oil, etc., or to large amounts of dust, use something to cover and protect the unit.

#### Switching valves

To switch between air supply or exhaust, rotate the knob by 90 degrees. Rotation to the left (counterclockwise direction) switches to the air supply state, while rotating to the right (clockwise direction) switches to the exhaust state. As there is no neutral position (where the P port air would return back to A or R), slowly rotating the knob can slowly increase the supply or exhaust volume. To determine the current valve state, check a display window on the side of the knob.

#### Air supply

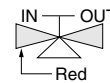

#### Exhaust

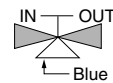

**Caution:** After switching the knob firmly by 90 degrees, always check that it is locked in place.



### General precautions

1. Always thoroughly blow off (use compressed air) the tubing before piping. Entering chips, sealing tape, rust, etc., generated during piping work could result in air leaks or other defective operation.
2. Use clean air for the media. Install an air filter (with filtration of a minimum 5 $\mu$ m). For the use of any other media, consult us.
3. The product cannot be used when the media or the ambient atmosphere contains any of the substances listed below. Organic solvents, phosphoric acid ester type hydraulic oil, sulphur dioxide, chlorine gas, acids, or alkali.
4. If using in locations subject to dripping water, dripping oil, etc., or to large amounts of dust, use something to cover and protect the unit.