

Low dust emissions

Softened shocks

Silicone-free

# Shock Absorbers with Clean Specifications

## Linear orifice type KSHC series (fixed type)

\* "Linear Orifice" is a registered trademark of Koganei Corporation.

### Low dust emissions

Capable of JIS/ISO Class 5 equivalent cleanliness (FED-STD Class 100 equivalent) calculated within a 0.1 μm particle. (Koganei standard)<sup>Note 1</sup>

A particle pocket structure is used to prevent the scattering of dust.

Note 1: Refer to page 59 for the Koganei standard.  
2: Packaged in single layer packaging.

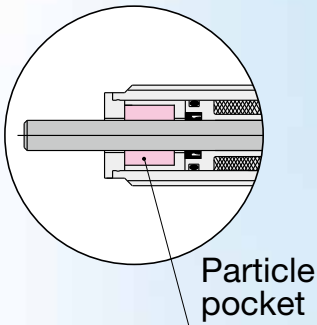

### Softened shocks

These shock absorbers achieve their smooth shock absorption characteristics thanks to the linear orifice structure. Reduces vibrations and shocks to bases and equipment.

### Silicone-free

Silicone is not used in the hydraulic oil or plastic.

Wide range of variations  
**M4 to M25**  
9 sizes and 40 models

Wide range of variations  
**10-32 UNF to 1-12 UNF**  
9 sizes and 36 models

### Linear orifices' long service life and softened shocks

These shock absorbers achieve their smooth shock absorption characteristics and a long service life thanks to the linear orifice structure that transforms the orifice linearly. Since the linear orifice structure can increase the inner diameter of the shock absorbers without needing an inner tube, the shock absorbers demonstrate similar characteristics to shock absorbers one thread size larger, as well as reduce the vibrations and shocks to bases and equipment.

**Principles of operation**  
The piston stroke squeezes the oil's flow path steplessly to softly absorb shocks.

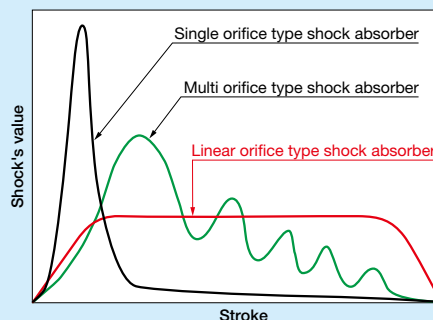
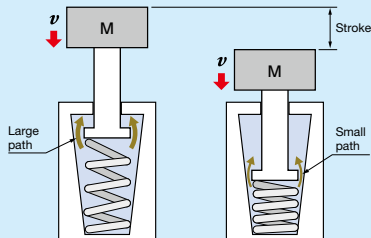

# Linear Orifice Type KSHC Series Clean Room Specification Shock Absorbers



**JIS/ISO Class 5 compliant**  
(FED-STD Class 100 equivalent)

**Smallest  
M4 size**



**CS-KSHC3×3**

KSHJ

KSHY

KSHP

KSHC

Additional Parts

## Handling instructions and precautions



### General precautions

Cover the unit when mounting it in locations where it might be subject to excessive dust, dripping water, dripping oil, etc. Dents, scratches, water, oil, or dust on the piston rod results in damage and decreases service life.



### Mounting

1. Keep the angle of eccentricity, resulting from the load direction and the axis of the shock absorber, under the specified values on pages 65 to 66. If an eccentric load exceeding the specifications is applied, it could result in breakage or impaired returns. If there is concern that an eccentric load exceeding the specified values will be applied, install a guide, or similar mechanism.
2. Two or more shock absorbers can be mounted in parallel, to boost absorption capacity. In such an arrangement, however, be careful to ensure that the load is evenly distributed to each shock absorber.
3. To adjust the capacity with the stroke, adjust the stopper nut (-S) or add an external stopper.
4. If using with a cap, always mount a stopper nut (-S) or an external stopper to ensure that the cap is not subjected to loads at the stroke end. The stopper nut mounting position must not exceed the distance shown in the table below. You can use it without a stopper nut or external stopper, but over the long-term, the stop location changes due to cap deformation and wear.

Model	A	
	mm	in
CS-KSHC3 × 3C(-F11)	3	0.118
CS-KSHC4 × 4C(-F11)	4	0.157
CS-KSHC5 × 5C(-11)(-F11)	5	0.197
CS-KSHC6 × 8C(-F11)	8	0.315
CS-KSHC7 × 8C-F11	—	0.315
CS-KSHC8 × 8C(-F11)	8	0.315
CS-KSHC9 × 10C(-F11)	10	0.394
CS-KSHC11 × 15C(-F11)	15	0.591
CS-KSHC14 × 16C	16	0.630
CS-KSHC18 × 25C(-F11)	25	0.984

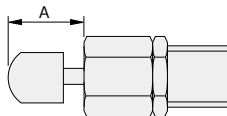

5. The small screw on the back end of the shock absorber should never be loosened or removed. Oil may leak out of the shock absorber leading to a loss of functionality and resulting in damage to the equipment and accidents.

6. When mounting the shock absorber, always use the following maximum tightening torque guidelines. Tightening using excessive force may result in damage.

Model	Maximum tightening torque	
	N · m	in · lbf
CS-KSHC3 × 3(C)(-F11)	0.5	4.426
CS-KSHC4 × 4(C)(-F11)	0.85	7.523
CS-KSHC5 × 5(C)(-11)(-F11)	2.5	22.128
CS-KSHC6 × 8(C)(-F11)	6.5	57.532
CS-KSHC7 × 8C-F11	—	57.5
CS-KSHC8 × 8(C)(-F11)	12.0	106.2
CS-KSHC9 × 10(C)(-F11)	12.0	106.2
CS-KSHC11 × 15(C)(-F11)	20.0	177.0
CS-KSHC14 × 16(C)	30.0	265.5
CS-KSHC18 × 25(C)(-F11)	42.0	371.7

7. Ensure that the hardness of the surface directly impacting the piston rod of the shock absorber is over HRc40 hardness (excluding models with cap).
8. Be aware that performance and characteristics change depending on the operating temperature.



## Selection guidelines

### How to select shock absorbers

#### 1. Confirm the thrust

Confirm the thrust that is used, and then check the prospective shock absorbers from the table of recommended cylinder bore sizes on page 63. If a shock absorber that is smaller than the recommended shock absorber is used, the shock absorber being used may be damaged in fewer operation cycles than is guaranteed.

#### 2. Confirm the kinetic energy

Confirm I and II below, and then check page 64 for the selection graph for prospective shock absorbers from [1. Confirm the thrust]. (\*)

I Impact object mass:  $m$  [kg]

II Impact speed:  $v$  [m/s]

Because “ $v$ ” is the impact speed, not the average speed, when using a cylinder,

$$v = m [\text{cylinder stroke}] \div s [\text{operating time}] \times 2$$

Select a model in which I and II fit within the range enclosed by the capacity curves.

If multiple models are applicable, use the model that is closest to both the capacity curves and the operating conditions. The further the model you select is from the capacity curves and the operating conditions, the slower it will tend to be.

#### 3. Confirm other specifications

Confirm that such specifications as the maximum operating frequency, maximum absorption capacity per unit of time, angle of eccentricity, and operating temperature range are within the range for the shock absorber that you selected.

\* The value for the kinetic energy,  $E$ , can be found by doing the following calculation. However, the shock absorber's capacity for absorption changes depending on the impact speed. When the shock absorber is doing low-speed operations, it has less drag than when it is doing high-speed operations.

The maximum absorption capacity that is noted in the specifications is reached only at the maximum impact speed.

Therefore, do not choose a shock absorber by comparing  $E$  to the maximum absorption capacity; confirm the capacity using the selection graph.

$$E = \frac{1}{2} mv^2$$

$E$ : Kinetic energy (J)

$m$ : Impact object mass [kg]

$v$ : Impact speed (m/s)

#### Range in the selection graph

Vertical axis range :

$$\text{Maximum impact speed} \geq v \text{ Impact speed (operating condition)}$$

Horizontal axis range :

$$\text{Shock absorber's maximum absorption capacity at the impact speed (} v = m/s \text{)} \geq \text{Kinetic energy (operating condition)}$$

Calculating the thrust energy is not necessary because the size of the shock absorber is limited by the thrust in step 1.

#### Example of selecting a shock absorber

[Operating conditions]

① Bore size of the cylinder being used:  $\phi 16$

② Cylinder stroke: 100 mm = 0.1 m

③ Pressure applied to the cylinder: 0.6 MPa

④ Cylinder's operating time: 0.4 s

⑤ Impact object mass: 10 kg

#### 1. Confirm the thrust

Either calculate or find the thrust in the cylinder thrust table on page 63.

The cylinder thrust based on ① and ③ is about 121 N.

Cylinder thrust	100.5N	<	120.6N	<	126N
Cylinder bore size	$\phi 16$		$\phi 16$		$\phi 20$
Applied pressure	0.5MPa		0.6MPa		0.4MPa

As mentioned above, although the cylinder being used is  $\phi 16$ , the pressure applied to the cylinder exceeds 0.5 MPa, so consider the  $\phi 20$  cylinder (lower than 0.4 MPa) and check the table of recommended cylinder bore sizes on page 63.

The following are prospective models.

- CS-KSHC6  $\times$  8
- CS-KSHC8  $\times$  8
- CS-KSHC9  $\times$  10
- CS-KSHC11  $\times$  15

#### 2. Confirm the kinetic energy

I The impact object mass  $m = 10$  kg from ⑤

II Find the impact speed,  $v$ , from ② and ④.

$$v = ② 0.1 \text{ m} \div ④ 0.4 \text{ s} \times 2 = 0.5 \text{ m/s}$$

According to the selection graph on page 64, the shock absorber with the optimum absorption capacity for operating conditions is CS-KSHC8  $\times$  8-EF.

#### CS-KSHC6 $\times$ 8

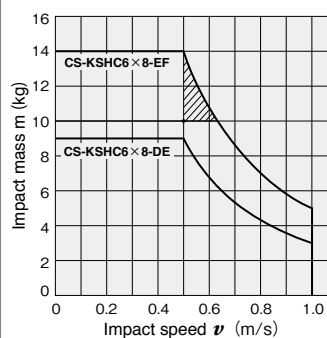

#### CS-KSHC8 $\times$ 8

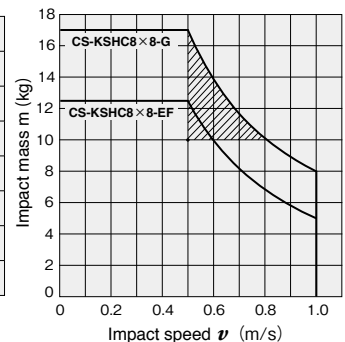

#### CS-KSHC9 $\times$ 10

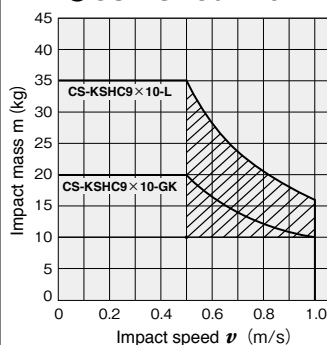

- CS-KSHC6  $\times$  8-DE has an insufficient absorption capacity.
- The absorption capacities for all of the other shock absorbers are higher than that of CS-KSHC8  $\times$  8-EF, so they do not fall within the operating conditions and capacity curves.

#### 3. Confirm other specifications

Verify that other operating conditions, such as the maximum operating frequency, maximum absorption capacity per unit of time, angle of eccentricity, and operating temperature range, are within the specified ranges for CS-KSHC8  $\times$  8-EF.

## Selection guidelines

### Recommended cylinder bore size

Model	Cylinder bore													
	φ 4	φ 6	φ 8	φ 10	φ 12	φ 16	φ 20	φ 25	φ 32	φ 40	φ 50	φ 63	φ 80	φ 100
CS-KSHC3×3(-F11)	◇	◎	◎	○										
CS-KSHC4×4(-F11)		◇	◎	○										
CS-KSHC5×5(-F11)			◇	◎	◎	○								
CS-KSHC6×8(-F11)				◇	◎	◎	○							
CS-KSHC7×8-F11					◎	◎	○							
CS-KSHC8×8(-F11)						◇	◎	○						
CS-KSHC9×10(-F11)						◇	◎	◎	○					
CS-KSHC11×15(-F11)							◇	◎	◎	○				
CS-KSHC14×16									◇	◎	◎	○		
CS-KSHC18×25(-F11)										◇	◎	◎	○	○

◇ : 0.3 MPa or higher    ◎ : 0.5 MPa or lower    ○ : 0.4 MPa or lower

Note1: If a shock absorber that is smaller than the recommended shock absorber is used, the shock absorber being used may be damaged in fewer operation cycles than the value that is guaranteed.

Note2: CS-KSHC7×8 has only inch specifications.

### Cylinder thrust

N [lbf.]

Bore size mm [in.]	Pressure area mm <sup>2</sup> [in. <sup>2</sup> ]	Air pressure MPa [psi.]								
		0.1 [15]	0.2 [29]	0.3 [44]	0.4 [58]	0.5 [73]	0.6 [87]	0.7 [102]	0.8 [116]	0.9 [131]
φ4	12.6 [0.020]	1.3 [0.292]	2.5 [0.562]	3.8 [0.854]	5 [1.124]	6.3 [1.416]	7.5 [1.686]	8.8 [1.978]	10.1 [2.270]	11.3 [2.540]
φ6	28.3 [0.044]	2.8 [0.629]	5.7 [1.281]	8.5 [1.911]	11.3 [2.540]	14.1 [3.170]	17.0 [3.822]	19.8 [4.451]	22.6 [5.080]	25.4 [5.710]
φ8	50.3 [0.078]	5 [1.124]	10.1 [2.270]	15.1 [3.394]	20.1 [4.518]	25.1 [5.642]	30.2 [6.789]	35.2 [7.913]	40.2 [9.037]	45.2 [10.161]
φ10	78.5 [0.122]	7.9 [1.776]	15.7 [3.529]	23.6 [5.305]	31.4 [7.059]	39.3 [8.835]	47.1 [10.588]	55 [12.364]	62.8 [14.117]	70.7 [15.893]
φ12	113 [0.175]	11.3 [2.540]	22.6 [5.080]	33.9 [7.621]	45.2 [10.161]	56.5 [12.701]	67.9 [15.264]	79.2 [17.804]	90.5 [20.344]	101.8 [22.885]
φ16	201 [0.312]	20.1 [4.518]	40.2 [9.037]	60.3 [13.555]	80.4 [18.074]	100.5 [22.592]	121 [27.201]	141 [31.697]	161 [36.193]	181 [40.689]
φ20	314 [0.487]	31.4 [7.059]	62.8 [14.117]	94.2 [21.176]	126 [28.325]	157 [35.294]	188 [42.262]	220 [49.456]	251 [56.425]	283 [63.618]
φ25	491 [0.761]	49.1 [11.038]	98.2 [22.075]	147 [33.046]	196 [44.061]	245 [55.076]	295 [66.316]	344 [77.331]	393 [88.346]	442 [99.362]
φ32	804 [1.246]	80.4 [18.074]	161 [36.193]	241 [54.177]	322 [72.386]	402 [90.370]	483 [108.6]	563 [126.6]	643 [144.5]	724 [162.8]
φ40	1257 [1.948]	126 [28.325]	251 [56.425]	377 [84.750]	503 [113.1]	628 [141.2]	754 [169.5]	880 [197.8]	1005 [225.9]	1131 [254.2]
φ50	1963 [3.043]	196 [44.061]	393 [88.346]	589 [132.4]	785 [176.5]	982 [220.8]	1178 [264.8]	1374 [308.9]	1571 [353.2]	1767 [397.2]
φ63	3117 [4.831]	312 [70.138]	623 [140.1]	935 [210.2]	1247 [280.3]	1559 [350.5]	1870 [420.4]	2182 [490.5]	2494 [560.7]	2806 [630.8]
φ80	5027 [7.792]	503 [113.1]	1005 [225.9]	1508 [339.0]	2011 [452.1]	2513 [564.9]	3016 [678.0]	3519 [791.1]	4021 [903.9]	4524 [1017]
φ100	7854 [1.217]	785 [176.5]	1571 [353.2]	2356 [529.6]	3142 [706.3]	3927 [882.8]	4712 [1059]	5498 [1236]	6283 [1412]	7069 [1589]

## Selection guidelines

### Cautions for using the selection graphs

1. The selection graphs are calculated with a cylinder operating air pressure of 0.5 MPa.
2. The values in the selection graphs are for room temperature (20 to 25°). Be aware that performance and characteristics change depending on the operating temperature.
3. Select a shock absorber that is as close to, yet within, the capacity line(s).

### ■ Selection graph

#### ● CS-KSHC3 × 3 (-F11)

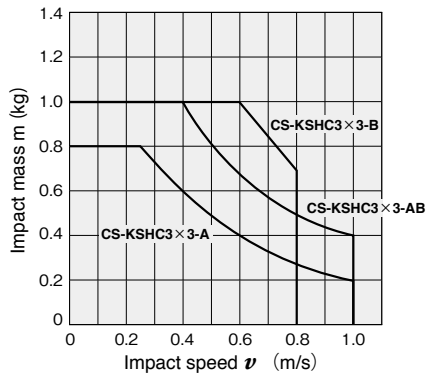

#### ● CS-KSHC4 × 4 (-F11)

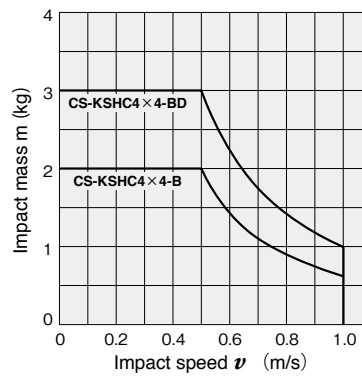

#### ● CS-KSHC5 × 5 (-F11)

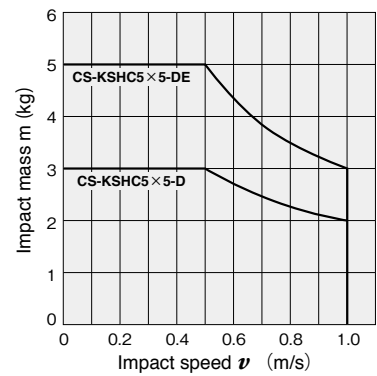

#### ● CS-KSHC6 × 8 (-F11)

#### ● CS-KSHC7 × 8-F11

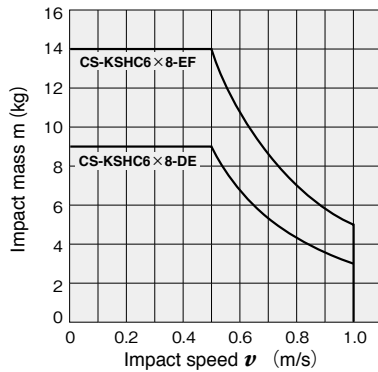

#### ● CS-KSHC8 × 8 (-F11)

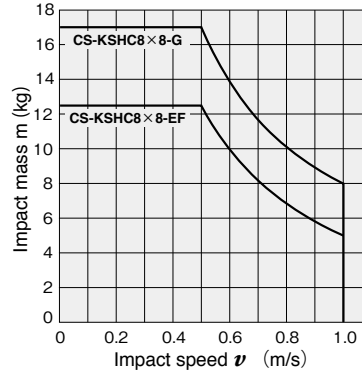

#### ● CS-KSHC9 × 10 (-F11)

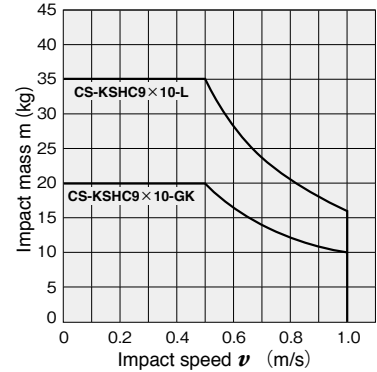

#### ● CS-KSHC11 × 15 (-F11)

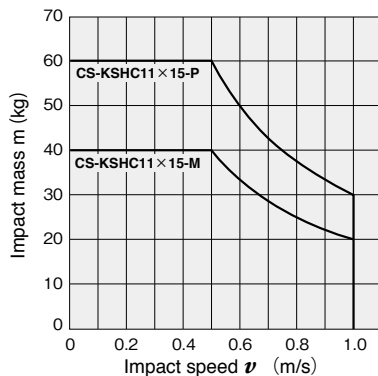

#### ● CS-KSHC14 × 16

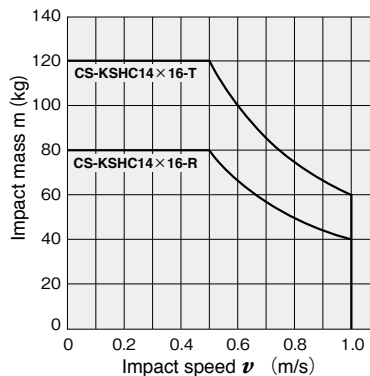

#### ● CS-KSHC18 × 25 (-F11)

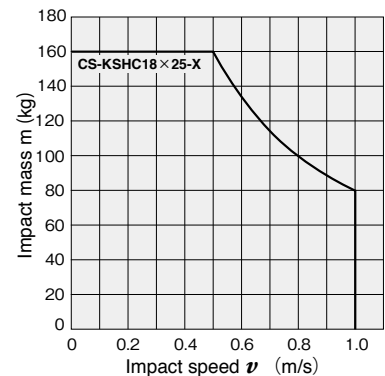

Clean room specifications  
**Shock absorber**  
 Linear orifice type

**KSHC Series**



**Specifications**

Item	Model (in inches)	CS-KSHC3×3-A (CS-KSHC3×3-A-F11)	CS-KSHC3×3-AB (CS-KSHC3×3-AB-F11)	CS-KSHC3×3-B (CS-KSHC3×3-B-F11)
Maximum absorption capacity	J(in.lbs)	0.1 (0.885)	0.2 (1.770)	0.3 (2.655)
Absorption stroke	mm(in.)	3 (0.118)		
Impact speed range	m/s(ft/s)	0.1 to 1.0 (0.33 to 3.28)		0.1 to 0.8 (0.33 to 2.62)
Maximum operating cycle	cycle/min	60		
Maximum absorption capacity per unit of time	J/min (in.lbs/min)	10 (88.6)		
Spring return force <sup>Note 1</sup>	N	2.0		
Deflection angle		1° or less		
Operating temperature range <sup>Note 2</sup>	°C(°F)	0 to 60 (32 to 140)		

Item	Model (in inches)	CS-KSHC4×4-B (CS-KSHC4×4-B-F11)	CS-KSHC4×4-BD (CS-KSHC4×4-BD-F11)	CS-KSHC5×5-D-11 (CS-KSHC5×5-F11-D)	CS-KSHC5×5-DE-11 (CS-KSHC5×5-F11-DE)
Maximum absorption capacity	J(in.lbs)	0.3 (2.655)	0.5 (4.425)	1.0 (8.851)	1.5 (13.276)
Absorption stroke	mm(in.)	4 (0.157)		5 (0.197)	
Impact speed range	m/s(ft/s)	0.1 to 1.0 (0.33 to 3.28)			
Maximum operating cycle	cycle/min	60			
Maximum absorption capacity per unit of time	J/min (in.lbs/min)	15 (132.8)		45 (398.5)	
Spring return force <sup>Note 1</sup>	N	3.0		6.0	
Deflection angle		1° or less			
Operating temperature range <sup>Note 2</sup>	°C(°F)	0 to 60 (32 to 140)			

Item	Model (in inches)	CS-KSHC6×8-DE (CS-KSHC6×8-DE-F11) (CS-KSHC7×8-F11)	CS-KSHC6×8-EF (CS-KSHC6×8-EF-F11) (CS-KSHC7×8-F11)	CS-KSHC8×8-EF (CS-KSHC8×8-EF-F11)	CS-KSHC8×8-G (CS-KSHC8×8-G-F11)
Maximum absorption capacity	J(in.lbs)	1.5 (13.276)	2.5 (22.127)	2.5 (22.127)	4.0 (35.403)
Absorption stroke	mm(in.)	8 (0.315)			
Impact speed range	m/s(ft/s)	0.1 to 1.0 (0.33 to 3.28)			
Maximum operating cycle	cycle/min	60			
Maximum absorption capacity per unit of time	J/min (in.lbs/min)	75 (664.2)		120 (1062.7)	
Spring return force <sup>Note 1</sup>	N	8.5			
Deflection angle		1° or less			
Operating temperature range <sup>Note 2</sup>	°C(°F)	0 to 60 (32 to 140)			

Item	Model (in inches)	CS-KSHC9×10-GK (CS-KSHC9×10-GK-F11)	CS-KSHC9×10-L (CS-KSHC9×10-L-F11)	CS-KSHC11×15-M (CS-KSHC11×15-M-F11)	CS-KSHC11×15-P (CS-KSHC11×15-P-F11)
Maximum absorption capacity	J(in.lbs)	5.0 (44.254)	8.0 (70.806)	10 (88.507)	15 (132.8)
Absorption stroke	mm(in.)	10 (0.394)			15 (0.591)
Impact speed range	m/s(ft/s)	0.1 to 1.0 (0.33 to 3.28)			
Maximum operating cycle	cycle/min	60		40	
Maximum absorption capacity per unit of time	J/min (in.lbs/min)	240 (2125.4)		300 (2656.8)	
Spring return force <sup>Note 1</sup>	N	8.5		18	
Deflection angle		1° or less			
Operating temperature range <sup>Note 2</sup>	°C(°F)	0 to 60 (32 to 140)			

Note1: The spring return force is the force of the piston rod when it returns from a full stroke. It is not stable, so cannot be used as other than rod return.

2: The shock absorbing capacity fluctuates based on speed and ambient temperature. Always use a product that is within the range shown by the solid lines in the graphs on pages 64.

\* CS-KSHC7 has only inch specifications.

\* The maximum tightening torque of CS-KSHC7 is different from that of CS-KSHC6. See page 61 for details on the maximum tightening torque.

# Specifications

Item	Model (in inches)	CS-KSHC14×16-R	CS-KSHC14×16-T	CS-KSHC18×25-X (CS-KSHC18×25-F11-X)
Maximum absorption capacity	J(in.lbs)	20	30	40 (354.0)
Absorption stroke	mm(in.)	16		25 (0.984)
Impact speed range	m/s(ft/s)	0.1 to 1.0 (0.33 to 3.28)		
Maximum operating cycle	cycle/min	40		
Maximum absorption capacity per unit of time	J/min (in.lbs/min)	600	800 (7084.8)	
Spring return force <sup>Note 1</sup>	N	18.6	32	
Deflection angle		1° or less		
Operating temperature range <sup>Note 2</sup>	°C(°F)	0 to 60 (32 to 140)		

\*CS-KSHC14 does not have inch specifications.

# Order Codes (specifications in mm)

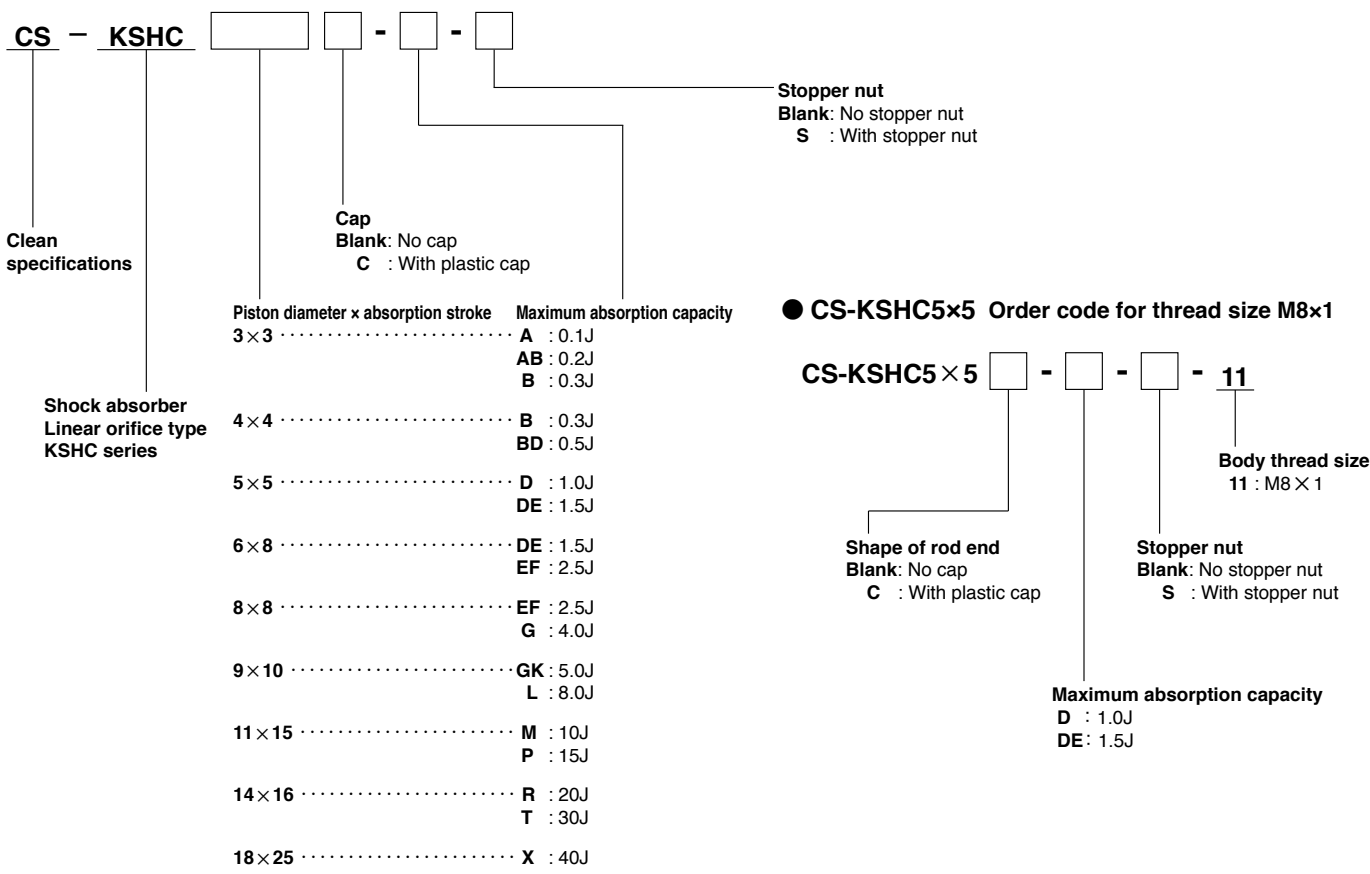

# Additional Parts (no specifications in inches)

## ● Stopper nut

S - KSH - M [ ]



- Thread size**
- 4 : For CS-KSHC3×3
  - 6 : For CS-KSHC4×4
  - 8 : For CS-KSHC5×5
  - 8-11 : For CS-KSHC5×5-11
  - 10 : For CS-KSHC6×8
  - 12 : For CS-KSHC8×8
  - 14 : For CS-KSHC9×10
  - 16 : For CS-KSHC11×15
  - 20 : For CS-KSHC14×16
  - 25 : For CS-KSHC18×25

## ● Mounting nut ( M4 to M20 : 1 pack has 10 pieces ) M25 : 1 pack has 2 pieces )

N - KSH - M [ ]



- Thread size**
- 4 : For CS-KSHC3×3
  - 6 : For CS-KSHC4×4
  - 8 : For CS-KSHC5×5
  - 8-11 : For CS-KSHC5×5-11
  - 10 : For CS-KSHC6×8
  - 12 : For CS-KSHC8×8
  - 14 : For CS-KSHC9×10
  - 16 : For CS-KSHC11×15
  - 20 : For CS-KSHC14×16
  - 25 : For CS-KSHC18×25

\* For the dimension diagrams of the additional parts, see page 72.

\* The stopper nut is made from mild steel (nickel plated).



## Mass (specifications in mm)

Model	Main unit <sup>Note</sup>	Additional mass		
		With plastic cap	Mounting nut (1 ea.)	Stopper nut
CS-KSHC3×3	1.8	0.1	0.2	0.8
CS-KSHC4×4	4.8	0.1	0.4	2
CS-KSHC5×5-01,-11	9.2	0.3	0.6(0.9)	4
CS-KSHC6×8	21	1	1.2	7
CS-KSHC8×8	32	1	1.9	8
CS-KSHC9×10	58	2	4	15
CS-KSHC11×15	94	2	6.6	29
CS-KSHC14×16	172	3	12.2	50
CS-KSHC18×25	350	7	23	100

Calculation example: The mass of CS-KSHC6×8 (with cap and stopper) is  
21 + 1 + 7 = 29g

Note: The weight of the main unit includes the weight of 2 mounting nuts.

## Inner Construction and Major Parts and Materials

- CS-KSHC3×3
- CS-KSHC4×4
- CS-KSHC5×5

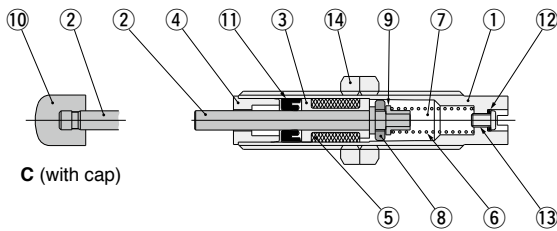

- CS-KSHC6×8
- CS-KSHC8×8
- CS-KSHC9×10

- CS-KSHC11×15
- CS-KSHC14×16
- CS-KSHC18×25

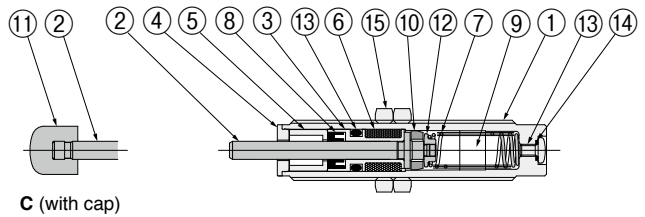

Note: Depending on size, some part shapes and configurations may differ.

- CS-KSHC3×3, 4×4, 5×5

No.	Name	Materials
①	Body <sup>Note 1</sup>	Copper alloy (nickel plated)
②	Piston rod <sup>Note 2</sup>	Steel (nickel plated)
③	Sleeve	Copper alloy
④	Plug	Stainless steel
⑤	Accumulator	Synthetic rubber
⑥	Spring	Spring steel
⑦	Oil	Special oil
⑧	Piston ring	Copper alloy
⑨	Collar <sup>Note 3</sup>	Copper alloy
⑩	Cap	Plastic (POM)
⑪	Rod seal	Synthetic rubber
⑫	O-ring	Synthetic rubber
⑬	Screw	Mild steel (nickel plated)
⑭	Mounting nut <sup>Note 4</sup>	Mild steel (nickel plated)

Note1: CS-KSHC3, 4 are stainless steel

2: CS-KSHC5 is stainless steel

3: CS-KSHC3 is stainless steel

4: CS-KSHC3 is stainless steel

- CS-KSHC6×8, 8×8, 9×10, 11×15, 14×16, 18×25

No.	Name	Materials
①	Body	Copper alloy (nickel plated)
②	Piston rod <sup>Note 1</sup>	Steel (nickel plated)
③	Sleeve	Copper alloy
④	Plug	Stainless steel
⑤	Spacer	Stainless steel
⑥	Accumulator	Synthetic rubber
⑦	Spring	Spring steel
⑧	Rod seal	Synthetic rubber
⑨	Oil	Special oil
⑩	Piston ring	Copper alloy
⑪	Cap	Plastic (POM)
⑫	Collar <sup>Note 2</sup>	Sintered metal
⑬	O-ring	Synthetic rubber
⑭	Screw	Mild steel (zinc plated)
⑮	Mounting nut	Mild steel (nickel plated)

Note1: CS-KSHC6, 8 are stainless steel

2: CS-KSHC11, 14, 18 are stainless steel

## Dimensions (mm)

● No rod end cap: CS-KSHC3×3, CS-KSHC4×4

● With rod end cap: CS-KSHC3×3C, CS-KSHC4×4C

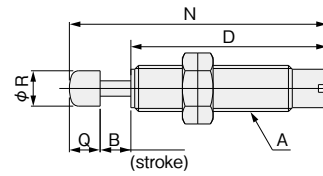
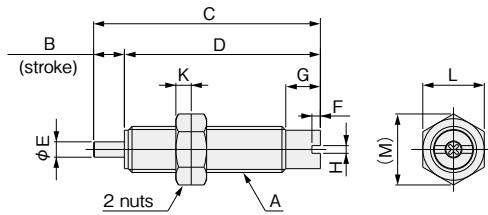

Model	Symbol	A	B	C	D	E	F	G	H	K	L	M	N	Q	R
CS-KSHC3×3□		M4×0.5	3	25	22	1.2	1.1	3	1	2	5.5	6.4	28.5	3.5	3.2
CS-KSHC4×4□		M6×0.75	4	33.5	29.5	2	1	5.5	1	2	8	9.2	37.5	4	4.6

● No rod end cap: CS-KSHC5×5-11

● With rod end cap: CS-KSHC5×5C-11

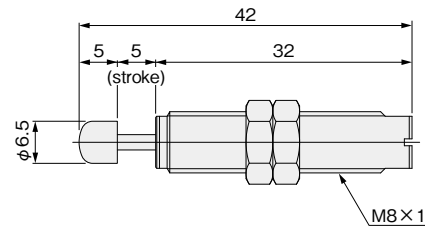
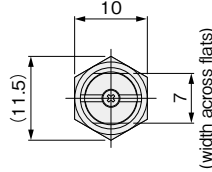
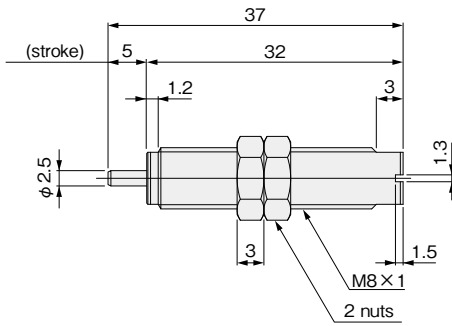

● No rod end cap: CS-KSHC□×□

● With rod end cap: CS-KSHC□×□C

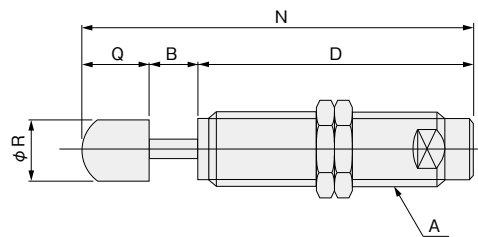
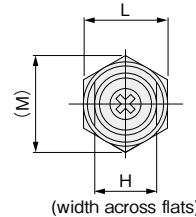
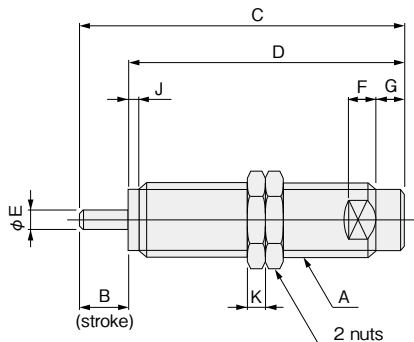

Model	Symbol	A	B	C	D	E	F	G	H	J	K	L	M	N	Q	R
CS-KSHC5×5□		M8×0.75	5	36	31	2.5	3	5	7	1.2	2	10	11.5	41	5	6.5
CS-KSHC6×8□		M10×1	8	53	45	3	4	5	9	2	3	12	13.9	61	8	8
CS-KSHC8×8□		M12×1	8	53	45	3	5	5.5	11	2	4	14	16.2	63	10	10
CS-KSHC9×10□		M14×1.5	10	70	60	4	5	5.5	12	2	5	17	19.6	80	10	11
CS-KSHC11×15□		M16×1.5	15	87	72	4	5	6	14	3	7	19	21.9	97	10	11
CS-KSHC14×16□		M20×1.5	16	98	82	5	6	6	18	3	8	24	27.7	113	15	15
CS-KSHC18×25□		M25×1.5	25	135	110	6	7	6	23	3	10	30	34.6	153	18	18

KSHJ

KSHY

KSHP

KSHC

Additional Parts

## Order Codes (specifications in inches)

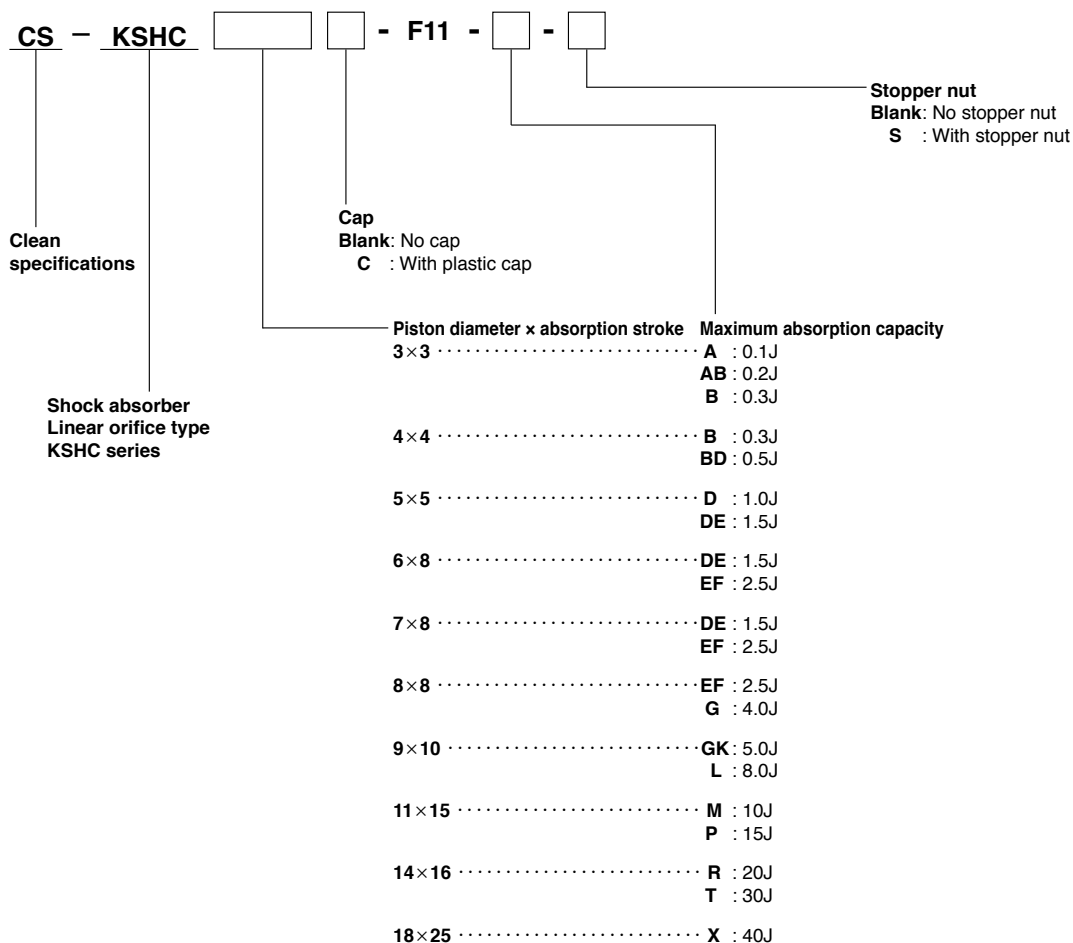

## Mass (specifications in inches)

oz

Model	Main unit <sup>Note1</sup>	Additional mass		
		With plastic cap	Mounting nut (1 ea.)	Stopper nut
CS-KSHC3×3-F11	0.1	0.004	0.01	0.04
CS-KSHC4×4-F11	0.2	0.004	0.04	0.1
CS-KSHC5×5-F11-D,DE	0.4	0.01	0.06	0.2
CS-KSHC6×8-F11	0.7	0.04	0.07	0.4
CS-KSHC7×8-F11	1.0	0.04	0.09	0.4
CS-KSHC8×8-F11	1.3	0.04	0.1	0.5
CS-KSHC9×10-F11	2.2	0.07	0.2	0.7
CS-KSHC11×15-F11	5.1	0.07	0.4	2.5
CS-KSHC18×25-F11	12.7	0.2	1.1	4.8

Calculation example: The mass of CS-KSHC6×8 (with cap and stopper) is  
 $0.7 + 0.04 + 0.4 = 1.14\text{oz}$

Note1: The weight of the main unit includes the weight of 2 mounting nuts.

Note2: CS-KSHC7×8 has only inch specifications.

## Dimensions (in)

● No rod end cap: CS-KSHC3×3, CS-KSHC4×4

● With rod end cap: CS-KSHC3×3C, CS-KSHC4×4C

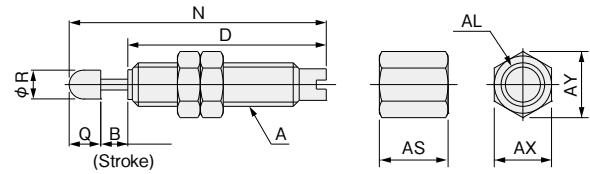
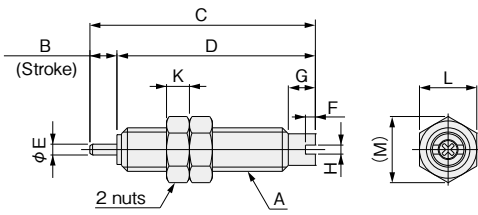

Model	Symbol	A	B	C	D	E	F	G	H	K	L	M	N	Q
CS-KSHC3×3 (C)-F11	#10-32 UNF	0.118	0.984	0.866	0.047	0.043	0.118	0.039	0.1	1/4	0.289	1.122	0.138	
CS-KSHC4×4 (C)-F11	1/4-32 UNEF	0.157	1.319	1.161	0.079	0.039	0.217	0.039	0.1	3/8	0.433	1.476	0.157	

Model	Symbol	R	AL	AS	AX	AY
CS-KSHC3×3 (C)-F11		0.126	#10-32 UNF	0.3	1/4	0.289
CS-KSHC4×4 (C)-F11		0.181	1/4-32 UNEF	0.4	3/8	0.433

● No rod end cap: CS-KSHC□×□

● With rod end cap: CS-KSHC□×□C

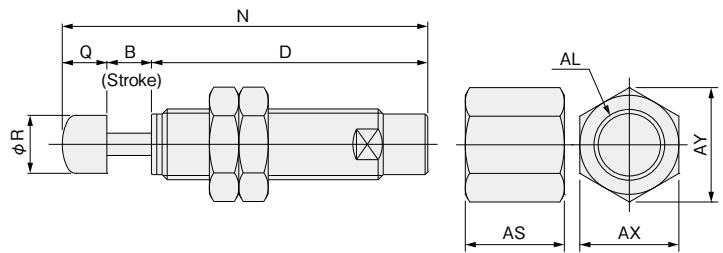
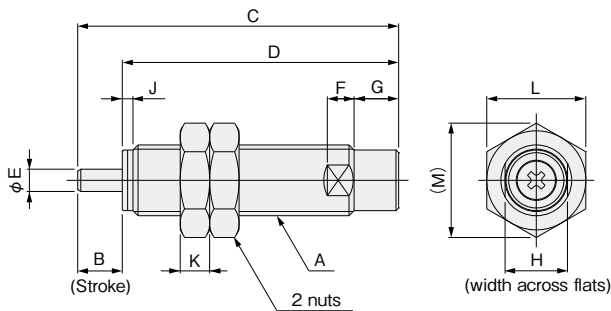

Model	Symbol	A	B	C	D	E	F	G	H	J	K	L	M	N	Q
CS-KSHC5×5 (C)-(-11)-F11	5/16-32 UNEF	0.197	1.417	1.22	0.098	0.118	0.197	0.276	0.047	0.13	7/16	0.505	1.614	0.197	
CS-KSHC6×8 (C)-F11	3/8-32 UNEF	0.315	2.087	1.772	0.118	0.157	0.197	0.354	0.079	0.13	1/2	0.577	2.401	0.315	
CS-KSHC7×8 (C)-F11	7/16-28 UNEF	0.315	2.087	1.772	0.118	0.157	0.197	3/8	0.079	0.15	9/16	0.65	2.401	0.315	
CS-KSHC8×8 (C)-F11	1/2-20 UNF	0.315	2.087	1.772	0.118	0.197	0.217	7/16	0.079	0.15	5/8	0.722	2.48	0.394	
CS-KSHC9×10 (C)-F11	9/16-18 UNF	0.394	2.756	2.362	0.157	0.197	0.217	1/2	0.079	7/32	11/16	0.794	3.15	0.394	
CS-KSHC11×15 (C)-F11	3/4-16 UNF	0.591	3.425	2.835	0.157	0.276	0.236	5/8	0.118	1/4	15/16	1.082	3.819	0.394	
CS-KSHC18×25 (C)-F11	1-12 UNF	0.984	5.315	4.331	0.236	0.276	0.236	0.875	0.118	3/8	1 1/4	1.443	6.024	0.709	

Model	Symbol	R	AL	AS	AX	AY
CS-KSHC5×5 (C)-(-11)-F11		0.256	5/16-32 UNEF	7/16	7/16	0.505
CS-KSHC6×8 (C)-F11		0.315	3/8-32 UNEF	11/16	1/2	0.577
CS-KSHC7×8 (C)-F11		0.315	7/16-28 UNEF	11/16	9/16	0.65
CS-KSHC8×8 (C)-F11		0.394	1/2-20 UNF	11/16	5/8	0.722
CS-KSHC9×10 (C)-F11		0.433	9/16-18 UNF	3/4	11/16	0.794
CS-KSHC11×15 (C)-F11		0.433	3/4-16 UNF	1 1/2	15/16	1.082
CS-KSHC18×25 (C)-F11		0.709	1-12 UNF	1 1/2	1 1/4	1.443

KSHJ

KSHY

KSHP

KSHC

Additional Parts

# About the evaluation of cleanliness (shock absorber KSHC series)

Currently, methods for evaluating the degree of cleanliness of shock absorbers are not defined by JIS or other standards. Because of this, Koganei devises its own independent measurement methods for cleanliness and does evaluations accordingly.

## ● Measurement method

1. We measure particles in the clean bench (Figure 1) without activating the shock absorber for measurements and the load driving cylinder in the clean bench (background measurement).<sup>Note</sup>

Note: Under the background measurement conditions, the number of particles measures zero.

2. We start driving a load to activate the shock absorber under the measurement conditions, and then measure the particles.

## ● Measurement conditions

- Load impact speed : 300mm/s
- Shock absorber operating frequency: 30cycle/min<sup>Note</sup>
- Particle measurement time : 1 minute
- Suction rate : 1cf/min
- Measured particles : 0.1μm or greater

For reference, a graph of actual values is shown in Figure 2. The number of particles is the average value of the test samples. Also, the smaller the angle of eccentricity when mounting the shock absorber, the lower the number of particles is likely to be. We recommend mounting the shock absorber so that its angle of eccentricity to the workpiece is as small as possible.

Note1: The number of particles is based on 30 operation cycles. When using the shock absorbers, the customer's evaluation should be based on the customer's own operation frequency.

2: FED-STD Class 1 equivalent.

3: The numbers of particles in the graph are actual values measured under Koganei standards, and are not intended to be guaranteed values.

## ● Outline of particle measuring device

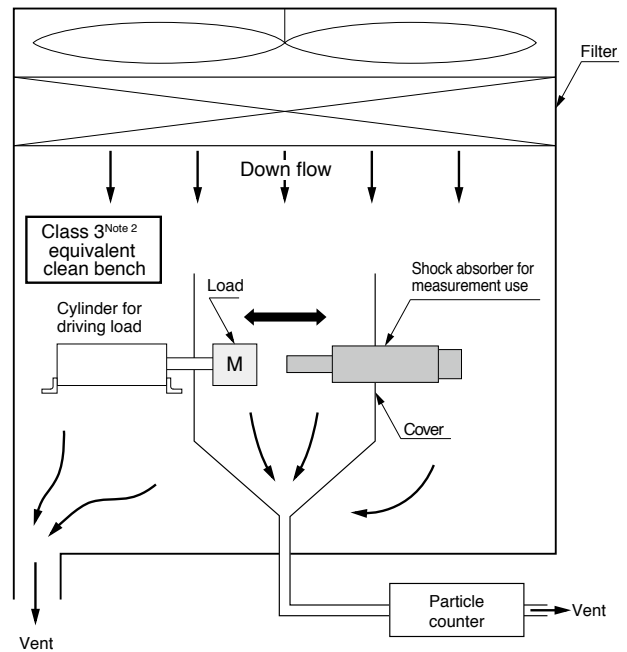

Figure 1

## ● Number of particles (measured value)<sup>Note 3</sup>

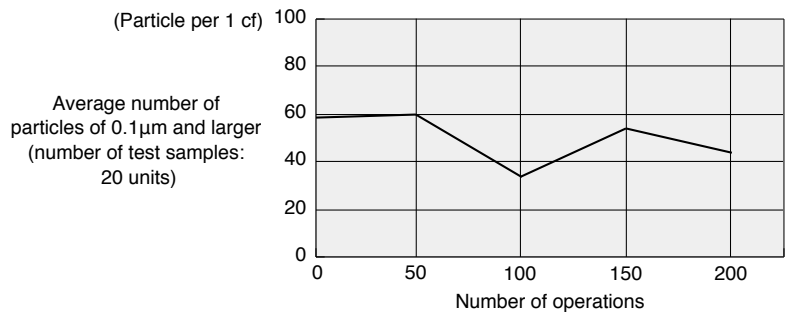

Figure 2

(Ten-thousand cycles)

1cf = 28.3 ℓ



## Dimensions of Additional Parts (mm)

### ● Mounting nut: N-KSH-□-□

### N-KSH-M45 (for KSHJ45)

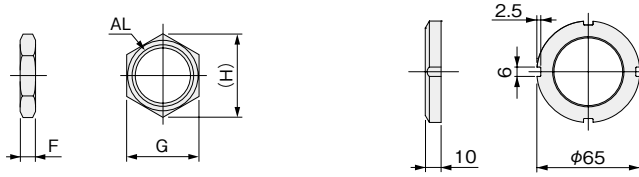

Symbol Model	AL	F	G	H	Applicable shock absorbers			
					KSHJ	KSHY	KSHP	CS-KSHC
N-KSH-M4	M4×0.5	2	5.5	6.4	KSHJ4	—	—	CS-KSHC3
N-KSH-M6	M6×0.75	2	8	9.2	KSHJ6	KSHY6	KSHP6	CS-KSHC4
N-KSH-M8	M8×0.75	2	10	11.5	KSHJ8(-01,02)	KSHY8(-01,02)	KSHP8	CS-KSHC5
N-KSH-M8-11	M8×1	3	10	11.5	KSHJ8(-11,12)	KSHY8(-11,12)	KSHP8-11	CS-KSHC5-11
N-KSH-M10	M10×1	3	12	13.9	KSHJ10	KSHY10	KSHP10	CS-KSHC6
N-KSH-M12	M12×1	4	14	16.2	KSHJ12	KSHY12	KSHP12	CS-KSHC8
N-KSH-M14	M14×1.5	5	17	19.6	KSHJ14	KSHY14	KSHP14	CS-KSHC9
N-KSH-M16	M16×1.5	7	19	21.9	KSHJ16	KSHY16	KSHP16	CS-KSHC11
N-KSH-M18	M18×1.5	8	21	24.2	KSHJ18	—	KSHP18	—
N-KSH-M20	M20×1.5	8	24	27.7	KSHJ20	KSHY20	KSHP20	CS-KSHC14
N-KSH-M22	M22×1.5	9	27	31.2	KSHJ22	—	—	—
N-KSH-M25	M25×1.5	10	30	34.6	KSHJ25-01	—	KSHP25	CS-KSHC18
N-KSH-M25-11	M25×2	10	30	34.6	KSHJ25(-11,12)	—	—	—
N-KSH-M27	M27×1.5	10	36	41.6	KSHJ27(-01,02)	—	—	—
N-KSH-M27-11	M27×3	12	36	41.6	KSHJ27(-11,12)	—	—	—
N-KSH-M30	M30×1.5	10	36	41.6	KSHJ30	—	KSHP30	—
N-KSH-M33	M33×1.5	10	41	47.3	KSHJ33	—	—	—
N-KSH-M36	M36×1.5	15	46	53.1	KSHJ36	—	KSHP36	—
N-KSH-M42	M42×1.5	15	50	57.7	KSHJ42	—	KSHP42	—
N-KSH-M48	M48×2	15	55	63.5	KSHJ48	—	—	—

### ● Stopper nut: S-KSH-□-□ (-2)

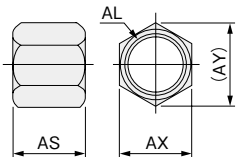

Symbol Model	AL	AS	AX	AY	Applicable shock absorbers			
					KSHJ	KSHY	KSHP	CS-KSHC
S-KSH-M4	M4×0.5	7.5	5.5	6.4	KSHJ4	—	—	CS-KSHC3
S-KSH-M6	M6×0.75	7	8	9.2	KSHJ6	—	KSHP6	CS-KSHC4
S-KSH-M6-L	M6×0.75	10	8	9.2	—	KSHY6	—	—
S-KSH-M8	M8×0.75	11	10	11.5	KSHJ8(-01,02)	KSHY8(-01,02)	KSHP8	CS-KSHC5
S-KSH-M8-11	M8×1	11	10	11.5	KSHJ8(-11,12)	KSHY8(-11,12)	KSHP6-11	CS-KSHC5-11
S-KSH-M10	M10×1	17	12	13.9	KSHJ10	KSHY10	KSHP10	CS-KSHC6
S-KSH-M12	M12×1	17	14	16.2	KSHJ12	KSHY12	KSHP12	CS-KSHC8
S-KSH-M14	M14×1.5	18	17	19.6	KSHJ14	KSHY14	KSHP14	CS-KSHC9
S-KSH-M16	M16×1.5	30	19	21.9	KSHJ16	KSHY16	KSHP16	CS-KSHC11
S-KSH-M18	M18×1.5	35	21	24.2	KSHJ18	—	KSHP18	—
S-KSH-M20	M20×1.5	35	24	27.7	KSHJ20	KSHY20	KSHP20	CS-KSHC14
S-KSH-M22	M22×1.5	40	27	31.2	KSHJ22	—	—	—
S-KSH-M25	M25×1.5	40	30	34.6	KSHJ25-01	—	KSHP25	CS-KSHC18
S-KSH-M25-11	M25×2	40	30	34.6	KSHJ25(-11,12)	—	—	—
S-KSH-M27	M27×1.5	40	36	41.6	KSHJ27(-01,02)	—	—	—
S-KSH-M27-11	M27×3	40	36	41.6	KSHJ27(-11,12)	—	—	—
S-KSH-M30	M30×1.5	40	36	41.6	KSHJ30	—	KSHP30	—
S-KSH-M33	M33×1.5	40	41	47.3	KSHJ33	—	—	—
S-KSH-M36	M36×1.5	50	46	53.1	KSHJ36	—	KSHP36	—
S-KSH-M42	M42×1.5	50	50	57.7	KSHJ42	—	KSHP42	—
S-KSH-M45	M45×1.5	60	55	63.5	KSHJ45	—	—	—
S-KSH-M48	M48×2	60	55	63.5	KSHJ48	—	—	—

## Dimensions of Additional Parts (mm)

### ●Side mounting bracket: 2-KSH-□-□ (-2)

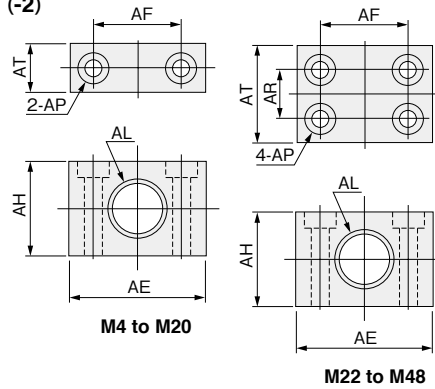

Symbol Model	AE	AF	AH	AL	AP	AR	AT	Applicable shock absorbers			
								KSHJ	KSHY	KSHP	CS-KSHC
2-KSH-M4	18	12	8	M4×0.5	φ 3.4, φ 6.5 Counter bore depth3.3	—	8	KSHJ4	—	—	CS-KSHC3
2-KSH-M6	18	12	10	M6×0.75	φ 3.4, φ 6.5 Counter bore depth3.3	—	8	KSHJ6	KSHY6	KSHP6	CS-KSHC4
2-KSH-M8	19	13	13	M8×0.75	φ 3.4, φ 6.5 Counter bore depth3.3	—	9	KSHJ8(-01,02)	KSHY8(-01,02)	KSHP8	CS-KSHC5
2-KSH-M8-11	19	13	13	M8×1	φ 3.4, φ 6.5 Counter bore depth3.3	—	9	KSHJ8(-11,12)	KSHY8(-11,12)	KSHP8-11	CS-KSHC5-11
2-KSH-M10	22	14	14	M10×1	φ 3.4, φ 6.5 Counter bore depth3.3	—	9	KSHJ10	KSHY10	KSHP10	CS-KSHC6
2-KSH-M12	25	16	18	M12×1	φ 3.4, φ 6.5 Counter bore depth3.3	—	9	KSHJ12	KSHY12	KSHP12	CS-KSHC8
2-KSH-M14	34	22	22	M14×1.5	φ 4.5, φ 8 Counter bore depth4.5	—	10	KSHJ14	KSHY14	KSHP14	CS-KSHC9
2-KSH-M16	38	25	25	M16×1.5	φ 4.5, φ 8 Counter bore depth4.5	—	12	KSHJ16	KSHY16	KSHP16	CS-KSHC11
2-KSH-M18	50	34	30	M18×1.5	φ 6.5, φ 11 Counter bore depth6.5	—	12	KSHJ18	—	KSHP18	—
2-KSH-M20	50	34	30	M20×1.5	φ 9, φ 14 Counter bore depth8.5	—	16	KSHJ20	KSHY20	KSHP20	CS-KSHC14
2-KSH-M22	60	44	35	M22×1.5	φ 9, φ 14 Counter bore depth8.5	19	35	KSHJ22	—	—	—
2-KSH-M25	60	44	35	M25×1.5	φ 9, φ 14 Counter bore depth8.5	19	35	KSHJ25-01	—	KSHP25	CS-KSHC18
2-KSH-M25-11	60	44	35	M25×2	φ 9, φ 14 Counter bore depth8.5	19	35	KSHJ25(-11,12)	—	—	—
2-KSH-M27	60	44	44	M27×1.5	φ 9, φ 14 Counter bore depth8.5	19	35	KSHJ27(-01,02)	—	—	—
2-KSH-M27-11	60	44	44	M27×3	φ 9, φ 14 Counter bore depth8.5	19	35	KSHJ27(-11,12)	—	—	—
2-KSH-M30	60	44	46	M30×1.5	φ 9, φ 14 Counter bore depth8.5	19	35	KSHJ30	—	KSHP30	—
2-KSH-M33	100	70	62	M33×1.5	φ 18, φ 26 Counter bore depth18	50	80	KSHJ33	—	—	—
2-KSH-M36	100	70	62	M36×1.5	φ 18, φ 26 Counter bore depth18	50	80	KSHJ36	—	KSHP36	—
2-KSH-M42	100	70	62	M42×1.5	φ 18, φ 26 Counter bore depth18	50	80	KSHJ42	—	KSHP42	—
2-KSH-M45	120	85	70	M45×1.5	φ 22, φ 32 Counter bore depth22	45	80	KSHJ45	—	—	—
2-KSH-M48	120	85	70	M48×2	φ 22, φ 32 Counter bore depth22	45	80	KSHJ48	—	—	—

MEMO

Horizontal dashed lines for writing.

KSHJ

KSHY

KSHP

KSHC

Additional Parts

# Limited Warranty

KOGANEI CORP. warrants its products to be free from defects in material and workmanship subject to the following provisions.

**Warranty Period** The warranty period is 180 days from the date of delivery.

**Koganei Responsibility** If a defect in material or workmanship is found during the warranty period, KOGANEI CORP. will replace any part proved defective under normal use free of charge and will provide the service necessary to replace such a part.

**Limitations**

- This warranty is in lieu of all other warranties, expressed or implied, and is limited to the original cost of the product and shall not include any transportation fee, the cost of installation or any liability for direct, indirect or consequential damage or delay resulting from the defects.

- KOGANEI CORP. shall in no way be liable or responsible for injuries or damage to persons or property arising out of the use or operation of the manufacturer's product.

- This warranty shall be void if the engineered safety devices are removed, made inoperative or not periodically checked for proper functioning.

- Any operation beyond the rated capacity, any improper use or application, or any improper installation of the product, or any substitution upon it with parts not furnished or approved by KOGANEI CORP., shall void this warranty.

- This warranty covers only such items supplied by KOGANEI CORP. The products of other manufacturers are covered only by such warranties made by those original manufacturers, even though such items may have been included as the components.

The specifications are subject to change without notice.

URL <http://www.koganei.co.jp>

E-mail: [overseas@koganei.co.jp](mailto:overseas@koganei.co.jp)



## KOGANEI CORPORATION

### OVERSEAS DEPARTMENT

3-11-28, Midori-cho, Koganei City, Tokyo 184-8533, Japan  
Tel: 81-42-383-7271 Fax: 81-42-383-7276

### KOGANEI INTERNATIONAL AMERICA, INC.

39300 Civic Center Dr., Suite 280, Fremont, CA 94538, U.S.A.  
Tel: 1-510-744-1626 Fax: 1-510-744-1676

### SHANGHAI KOGANEI INTERNATIONAL TRADING CORPORATION

Room 2606-2607, Tongda Venture Building No.1, Lane 600, Tianshan Road,  
Shanghai, 200051, China  
Tel: 86-21-6145-7313 Fax: 86-21-6145-7323

### TAIWAN KOGANEI TRADING CO., LTD.

Rm. 2, 13F., No88, Sec. 2, Zhongxiao E. Rd., Zhongzheng Dist., Taipei City 100,  
Taiwan (ROC)  
Tel: 886-2-2393-2717 Fax: 886-2-2393-2719

### KOGANEI KOREA CO., LTD.

KT&G Cosmo Bldg., 3F, 40-13, Maesanno 2-ga, Paldal-gu, Suwon-si, Gyeonggi-do,  
442-847, Korea  
Tel: 82-31-246-0414 Fax: 82-31-246-0415

### KOGANEI (THAILAND) CO., LTD.

3300/90, Tower B, Elephant Tower, 16th Fl., Phaholyothin Road, Chomphon,  
Chatuchak, Bangkok 10900, Thailand  
Tel: 66-2-937-4250 Fax: 66-2-937-4254

### KOGANEI ASIA PTE. LTD.

12 Arumugam road #03-12, Lion Building B, 409958, Singapore  
Tel: 65-6293-4512 Fax: 65-6293-4513