



Koganei Clean System products provide complete support for the maintenance of a clean environment inside the cleanroom.

Koganei Clean System products meet the needs of the ultra-clean production environment. In everything from actuators and valves to air preparation and auxiliary equipment, anti-corrosion materials processing and other Koganei-developed design concepts serve to prevent particle contamination within the cleanroom. These perfectly designed mechanisms, which resolve even the slightest leaks to the outside during operations, have already won a high level of reliability.

Koganei Cleanliness

There is currently no standard in JIS or elsewhere for methods of evaluating cleanliness for pneumatic equipment in the cleanroom specifications. Therefore, to measure the effects of cleanroom contamination by pneumatic equipment, Koganei has decided to use “number of particles generated per 10 operations,” rather than particle density. Koganei has also developed classifications for application classes in cleanroom, based on JIS and other upper limit density tables, and on the company’s own experience.

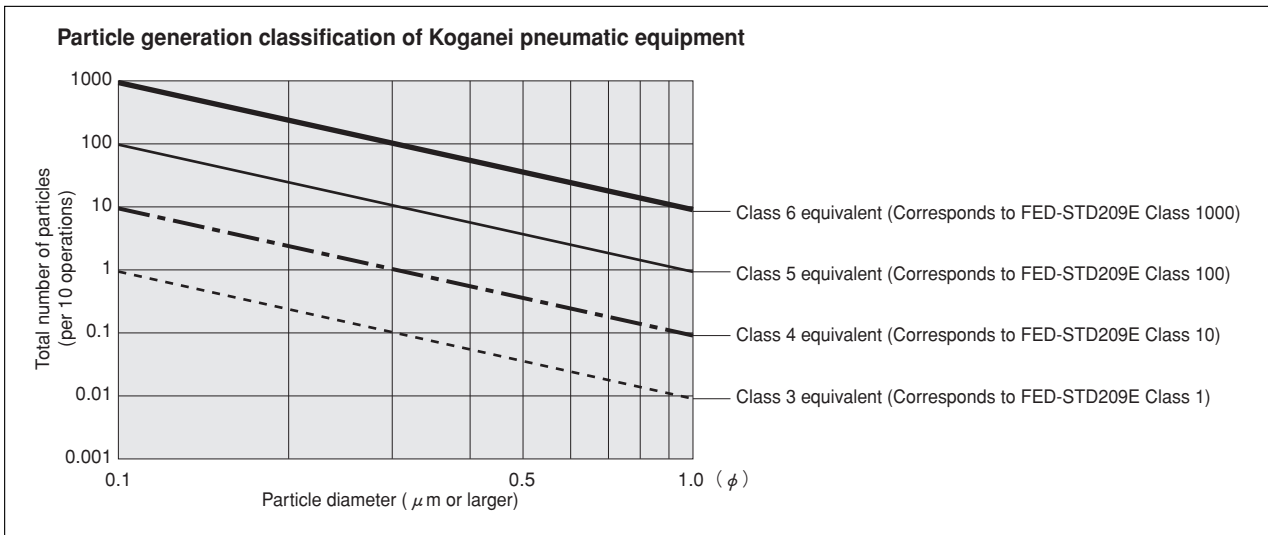

- Remarks:
1. In the above table, product performance in terms of the number of particles generated per 10 operations is expressed as the upper limit of particles corresponding to the equivalent JIS or ISO class.
 2. In the above table, values in the JIS, ISO, and FED-STD upper limit density tables are calculated as upper density per liter.
 3. The classes shown are clean levels as classified in JIS and ISO.

From the above definitions, the Koganei clean level classes can be viewed as the level of average contamination per liter of surrounding air over a period of 10 operations in cleanroom. Air ventilation in cleanrooms is usually faster than 1 cycle per minute, and clean volumetric capacity is usually larger than 1 liter, which should provide a sufficient safety margin in practice.

Caution: The above conclusions are based on an ideal situation in which air ventilation is being implemented. For specific cases where air ventilation is not ensured, caution is needed since the clean classes cannot be maintained.

The clean system diagrams shown here are for Class 5 equivalent products. For Class 4 or Class 3 equivalent products, consult us.

Evaluations of Cleanliness

Koganei has therefore specified its in-house measurement methods, to conduct evaluations on the cleanroom rating.

The number of particles of the Air Cylinder Cleanroom Specification is measured as shown in the method below.

1. Measurement conditions

1-1 Test circuit: Figure 1 (no suction), Figure 2 (with suction)

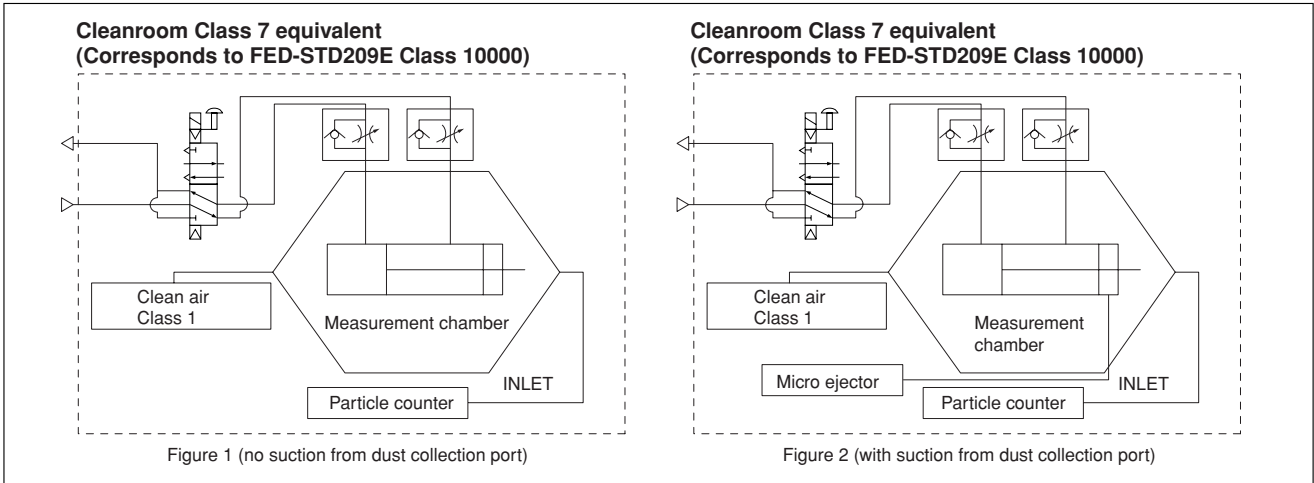

1-2 Operating conditions of tested cylinder

- Operating frequency: 1Hz
- Average speed: 500mm/s [20in./sec.]
- Applied pressure: 0.5MPa [73psi.]
- Suction condition: Microejector ME05, Primary side: 0.5MPa [73psi.] applied, Tube: $\phi 6$ [0.236in.]
- Mounting direction: Vertical
- Chamber volume: 8.3 ℓ [0.293ft.³]

2. Particle counter

- Manufacturer/model: RION/KM20
- Suction flow rate: 28.3 ℓ /min [1ft.³/min.]
- Particle diameter: 0.1 μm , 0.2 μm , 0.3 μm , 0.5 μm , 0.7 μm , 1.0 μm

3. Measurement method

- 3-1 Confirmation of number of particles in the measurement system
Under the conditions in the above 1 and 2, using a particle counter to measure the sample for 9 minutes without operating the measurement sample, and confirmed the measured number of particle is 1 piece or less.
- 3-2 Measurement under operation
Under the conditions in the above 1 and 2, operating the measurement sample for 36 minutes, and measured the total values in the latter half of 18 minutes test.
- 3-3 Reconfirmation
Performed the measurement in 3-1 again, to reconfirm the number of particles in the measurement system.

4. Measurement results

● Cleanroom specification

Jig Cylinder (no suction from dust collection port)

Particle generation over 1 million operations (CS-CDA16 \times 30)

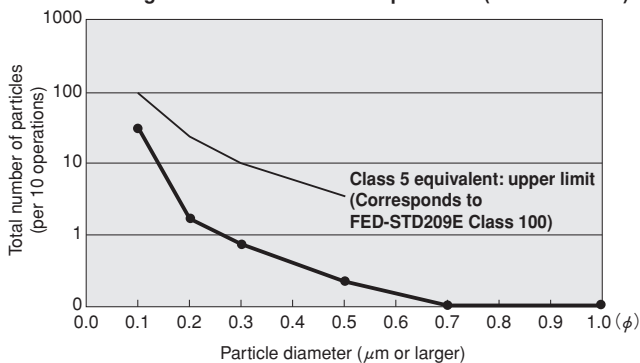

● Cleanroom specification

Slim Cylinder (with suction from dust collection port)

Particle generation over 1 million operations (CS-DA20 \times 100)

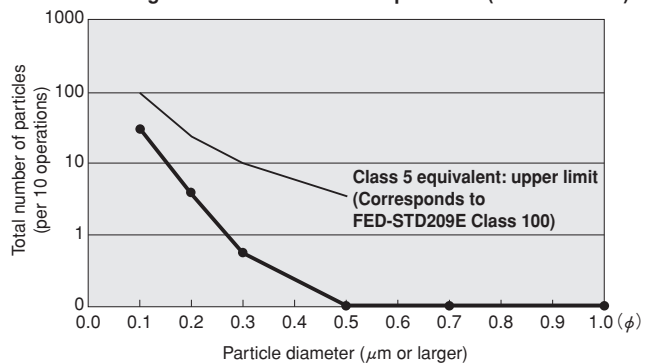

For “safety precautions” listed in the Clean System Product Drawings, see the materials below.

- For actuators, see “Safety Precautions” on p. 45 of the Actuators General Catalog .
- For valves, see “Safety Precautions” on p. 31 of the Valves General Catalog.
- For air treatment and auxiliary equipment, see “Safety Precautions” on p.31 of the General Catalog of Air Treatment, Auxiliary, Vacuum.

KOGANEI CLEAN SYSTEM SOLENOID VALVES JA SERIES



Symbols

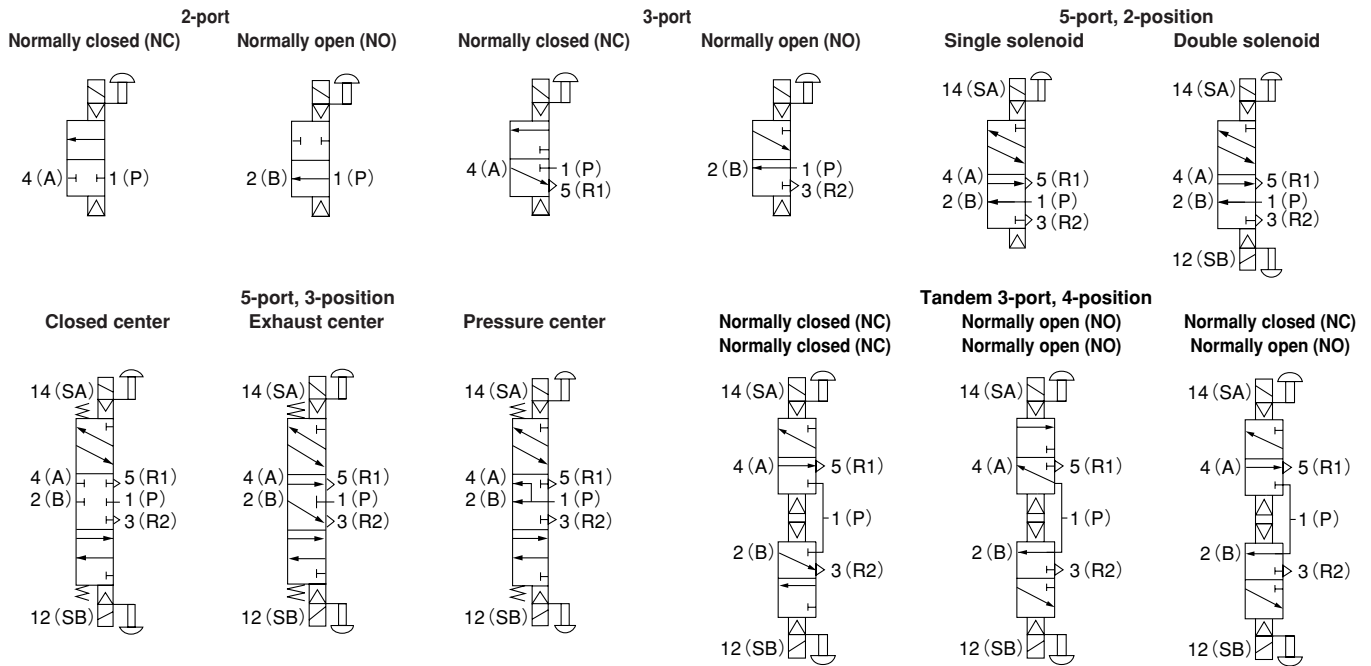

Specifications

Basic Models and Functions

Item	Basic model	CS-JA10□A1 CS-JA10□A2 CS-JA10□A3 CS-JA10□A4	CS-JA10□A5	CS-JA10□A6	CS-JA10□A7 CS-JA10□A8 CS-JA10□A9	CS-JA10□AA CS-JA10□AB CS-JA10□AC
Number of positions		2 positions			3 positions	4 positions
Number of ports		2, 3 ports	5 ports			Tandem 3 ports
Valve function		Single solenoid NC, NO	Single solenoid	Double solenoid	Closed center, Exhaust center, Pressure center	NC/NC, NO/NO, NC/NO

Remark: For the optional specifications and order codes, see p.185.

Port Size

Piping specification	Port	2 (B), 4(A)	1(P)	3, 5(R)
With sub-base		Rc1/8	Rc1/8	Rc1/8
Monoblock manifold		φ 4 or φ 6 fitting	Rc1/8	Rc1/8
Split manifold		φ 4 or φ 6 fitting	φ 8 fitting	φ 8 fitting or muffler

Specifications

Item	Basic model	CS-JA10□A1	CS-JA10□A5	CS-JA10□A6	CS-JA10□A7	CS-JA10□AA
		CS-JA10□A2			CS-JA10□A8	
		CS-JA10□A3			CS-JA10□A9	CS-JA10□AC
		CS-JA10□A4				
Media		Air				
Operation type		Internal pilot type				
Effective area [Cv]	mm ²	3.5 (0.19)			3.4 (0.19)	3.5 (0.19)
Port size ^{Note1}		φ 4 fitting, φ 6 fitting, Rc1/8				
Lubrication		Not required				
Operating pressure range	MPa [psi.]	0.2~0.7 [29~102]				
Proof pressure	MPa [psi.]	1.05 [152]				
Response time (ON/OFF) ^{Note 2}	ms	15/15 (15/20) or below	15 (20) or below	15/25 (15/35) or below	15/20 (15/30) or below	
Maximum operating frequency	Hz	5				
Minimum time to energize for self holding ^{Note3}	ms	—	50	—		
Operating temperature range (atmosphere and media)	°C [°F]	5~50 [41~122]				
Shock resistance	m/s ² {G}	245 [25]				
Mounting direction		Any				

Notes: 1. For details, see the port size on p.181.

2. Values when air pressure is 0.5MPa [73psi.]. Values in parentheses () are for the low-current specification. In addition, the values for the 3-position valves are switching time from neutral position.

3. For double solenoid valve.

Solenoid Specifications

Item	Rated voltage	DC24V (Standard specification)		DC24V (Low current specification)	
Operating voltage range	V	21.6~26.4 (24±10%)		21.6~26.4 (24±10%)	
Standard	Current (when rated voltage is applied) mA(r.m.s)	21		—	
	Power consumption W	0.5		—	
Low current specification	Current (when rated voltage is applied)	Starting mA	—	21	
		Holding mA	—	10.5	
	Power consumption	Starting W	—	0.5	
		Holding W	—	0.25	
Start-up time (standard time)	ms	—		50	
Allowable leakage current	mA	1.0			
Insulation resistance	MΩ	Over 100 (value at DC500V megger)			
Color of LED indicator		14 (SA) : Red, 12(SB) : Green			
Surge suppression (as standard)		Surge absorption transistor		Flywheel diode	

Operating Principles and Major Parts

2-port

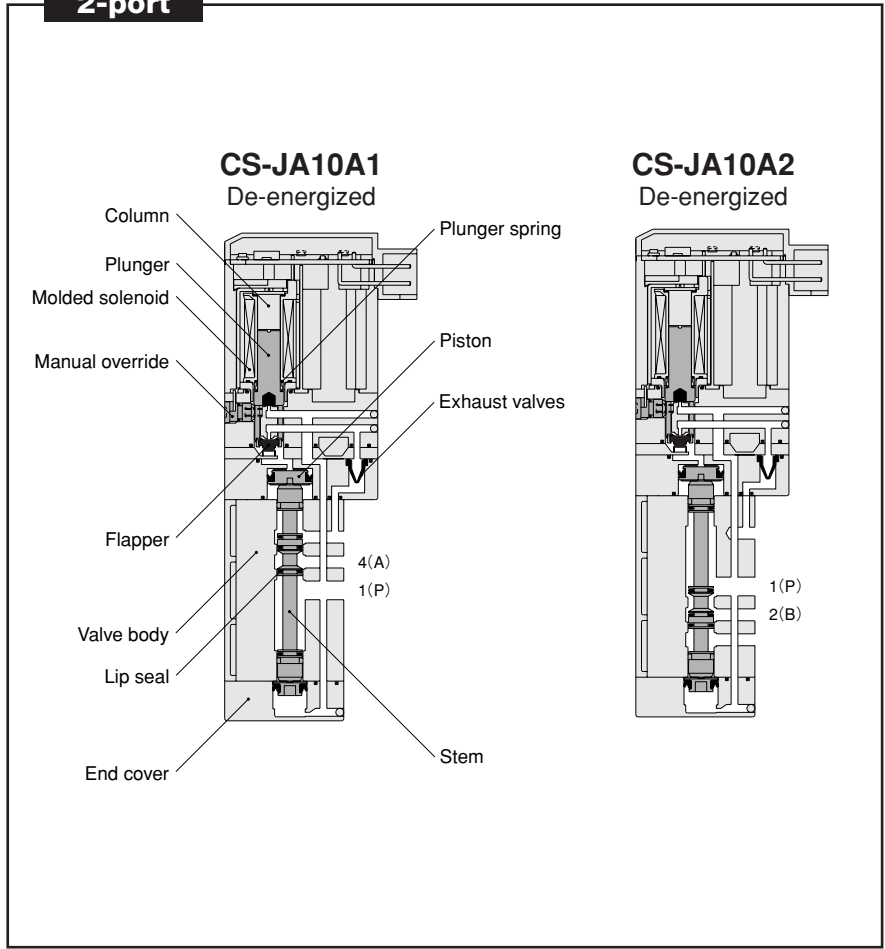

Major Parts and Materials

Parts		Materials
Valve	Body	Aluminum alloy (anodized)
	Stem	Aluminum alloy
	Exhaust valve	
	Lip seal	Synthetic rubber
	Flapper	
	Sub-base	Aluminum alloy (anodized)
	Plunger	Magnetic stainless steel
	Column	
Manifold	End cover	Plastic
	Body	Monoblock Aluminum alloy (anodized)
	Body	Split type Plastic
	Block-off plate	Mild steel (nickel plated)
Seal	Synthetic rubber	

3-port

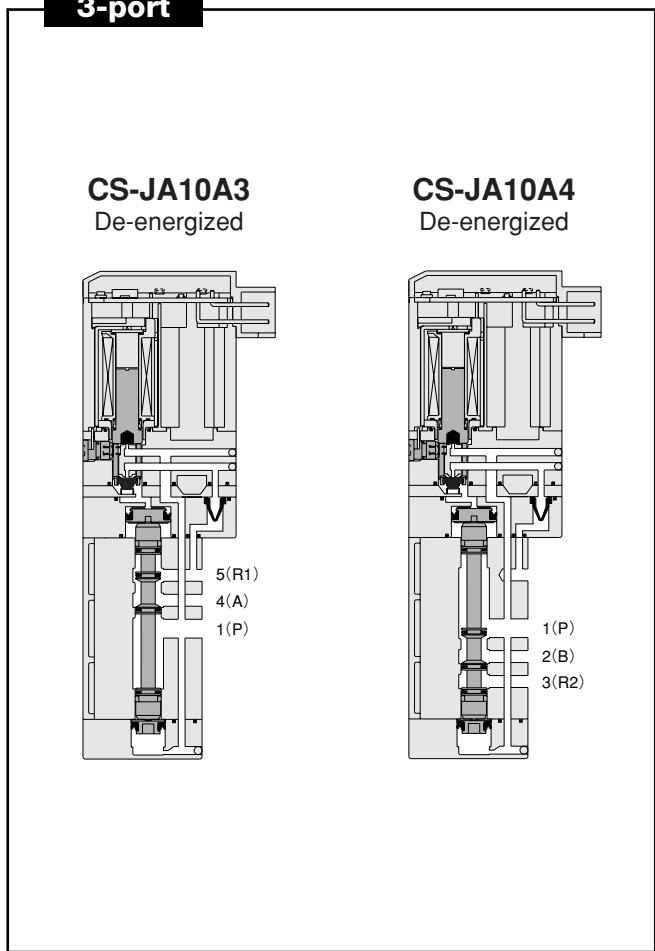

5-port, 2-position

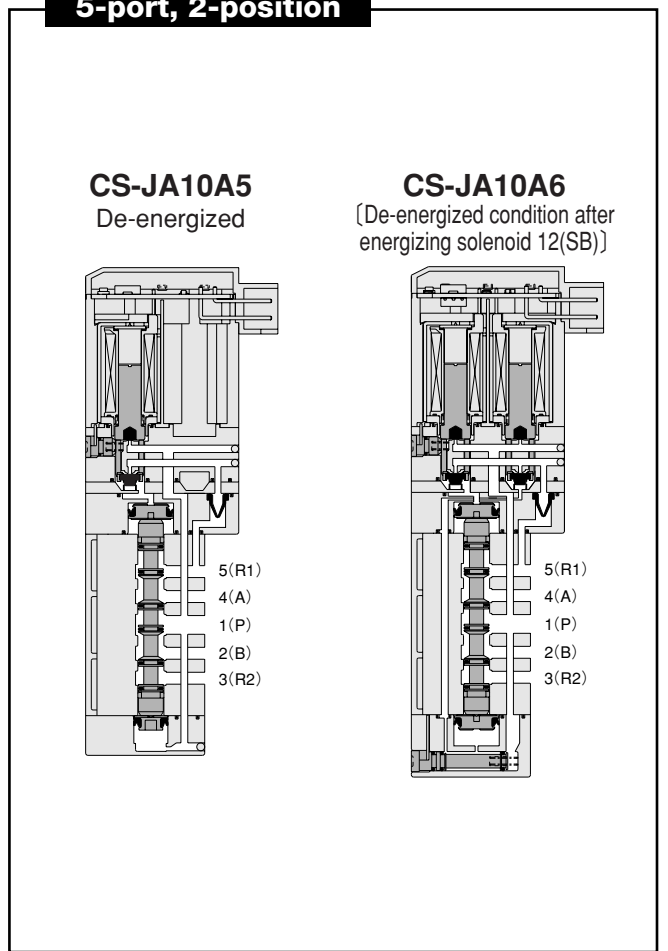

5-port, 3-position

[Both 14 (SA) and 12 (SB) are de-energized]

CS-JA10A7

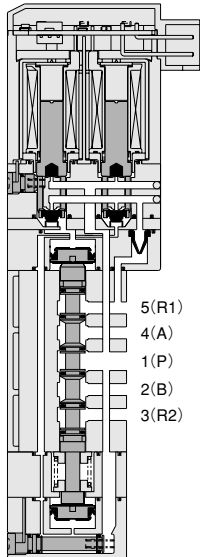

CS-JA10A8

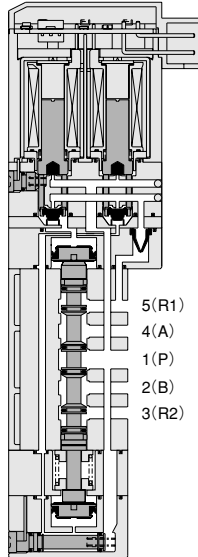

CS-JA10A9

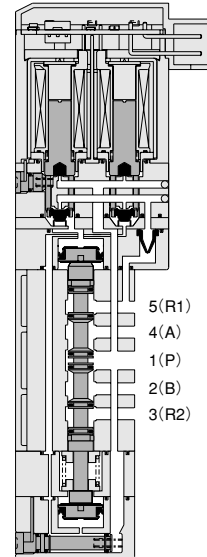

Tandem 3-port, 4-position

[Both 14 (SA) and 12 (SB) are de-energized]

CS-JA10AA

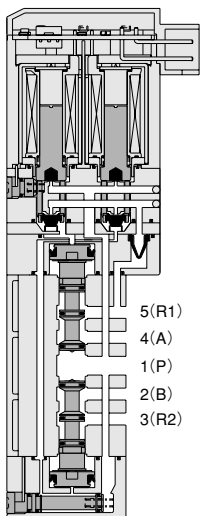

CS-JA10AB

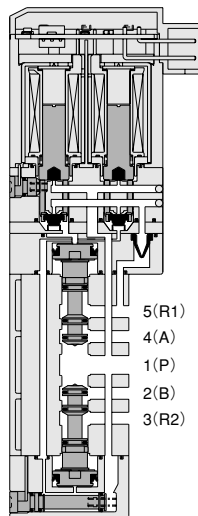

CS-JA10AC

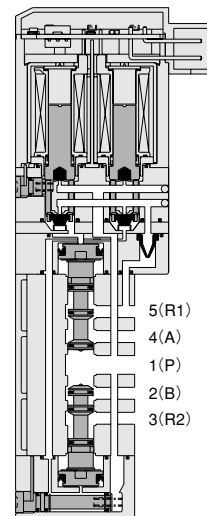

Single Valve Unit Order Codes



Model	Valve specification	Sub-base	Manual override	Wiring specification	Voltage
<p>CS-JA10 Standard type</p> <p>CS-JA10L Low current type</p>	<p>A1: 2-port normally closed</p> <p>A2: 2-port normally open</p> <p>A3: 3-port normally closed</p> <p>A4: 3-port normally open</p> <p>A5: 5-port 2-position, single solenoid</p> <p>A6: 5-port 2-position, double solenoid</p> <p>A7: 3-position, closed center</p> <p>A8: 3-position, exhaust center</p> <p>A9: 3-position, pressure center</p> <p>AA: Tandem 3-port (normally closed & normally closed)</p> <p>AB: Tandem 3-port (normally open & normally open)</p> <p>AC: Tandem 3-port (normally closed & normally open)</p>	<p>Without sub-base^{Note1}</p> <p>Blank</p> <p>With sub-base^{Note2}</p> <p>-25</p>	<p>Manual override</p> <p>Non-locking type</p> <p>Blank</p> <p>Locking protruding type</p> <p>-83</p>	<p>Wiring specification</p> <p>Plug-in</p> <p>S type plug connector Without connector and leads</p> <p>Blank</p> <p>-PN</p> <p>Positive common S type plug connector Lead wire 300mm [11.8in.]</p> <p>-PS</p> <p>Positive common S type plug connector Lead wire 3000mm [118in.]</p> <p>-PS3</p> <p>Negative common S type plug connector Lead wire 300mm [11.8in.]</p> <p>-MS</p> <p>Negative common S type plug connector Lead wire 3000mm [118in.]</p> <p>-MS3</p> <p>Voltage</p> <p>-D4 DC24V</p>	<p>-D4 DC24V</p>
<p>CS-JA10 CS-JA10L</p>	<p>A1 A2 A3 A4 A5 A6 A7 A8 A9 AA AB AC</p>	<p>Blank -25^{Note2}</p>	<p>Blank -83</p>	<p>Blank^{Note2} -PN -PS -PS3 -MS -MS3</p>	<p>-D4</p>

Notes: 1. Cannot be used as a single valve unit. Two manifold mounting screws are provided.
 2. When ordering with a sub-base, the "Blank (plug-in)" cannot be selected as the wiring specification. Select from among -PN, -PS, -PS3, -MS or -MS3.

Additional Parts Order Codes for Single Valve Unit

Parts for single valve unit

CS - JAZ -

Parts content

25 : Sub-base (sub-base and gasket)^{Note 1}

GS1 : Gasket^{Note 2}

Notes: 1. Valve mounting screws are not included.

2. Care should be taken that this gasket is different from the **GS2** gasket for the split manifolds.

Connector-related

CS - JAZ -

Connector specification

CP : Positive common plug connector, lead wire length 300mm [11.8in.]

CP3 : Positive common plug connector, lead wire length 3000mm [118in.]

CPN : Positive common plug connector, without lead wire (short bar and contacts included)

CM : Negative common plug connector, lead wire length 300mm [11.8in.]

CM3 : Negative common plug connector, lead wire length 3000mm [118in.]

CMN : Negative common plug connector, without lead wire (short bar and contacts included)

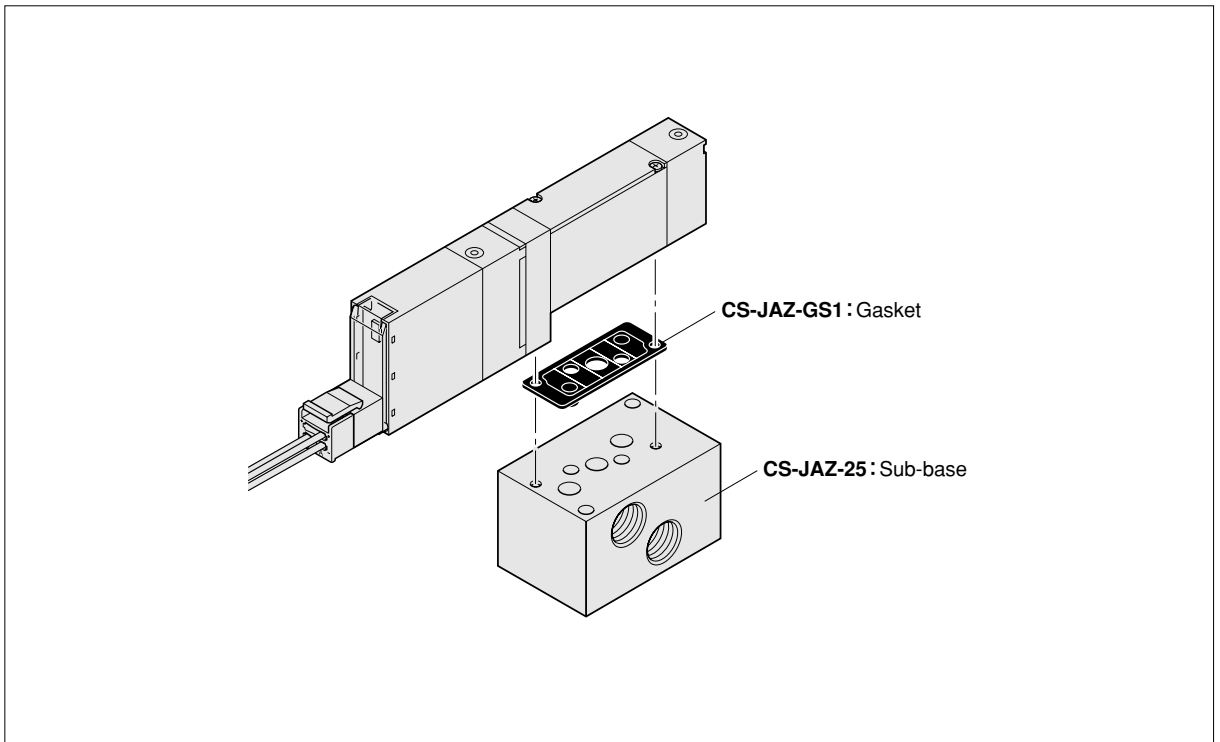

Monoblock Manifold Order Codes

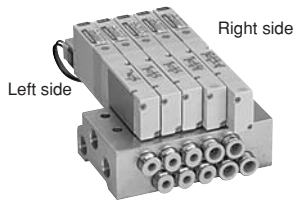

Model

CS-JA10

Standard type

CS-JA10L

Low current type

Valve specification

A1: 2-port normally closed

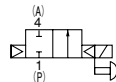

A2: 2-port normally open

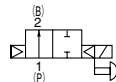

A3: 3-port normally closed

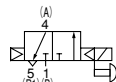

A4: 3-port normally open

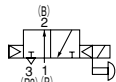

A5: 5-port 2-position, single sol.

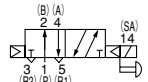

A6: 5-port 2-position, double sol.

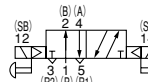

A7: 3-position, closed center

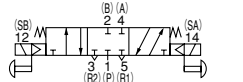

A8: 3-position, exhaust center

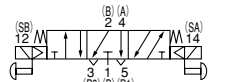

A9: 3-position, pressure center

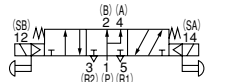

AA: Tandem 3-port (normally closed & normally closed)

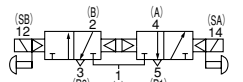

AB: Tandem 3-port (normally open & normally open)

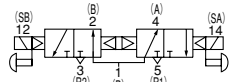

AC: Tandem 3-port (normally closed & normally open)

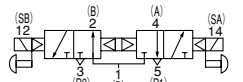

Manual override

Non-locking type

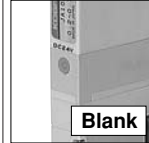

Locking protruding type



Wiring specification

S type plug connector
Without connector and leads

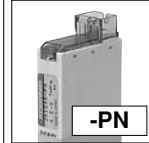

Positive common
S type plug connector
Lead wire 300mm [11.8in.]

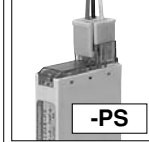

Negative common
S type plug connector
Lead wire 300mm [11.8in.]



Positive common
S type plug connector
Lead wire 3000mm [118in.]



Negative common
S type plug connector
Lead wire 3000mm [118in.]



Positive common pre-wired terminal
S type plug connector
Lead wire 300mm [11.8in.]



Negative common pre-wired terminal
S type plug connector
Lead wire 300mm [11.8in.]



Positive common pre-wired terminal
S type plug connector
Lead wire 3000mm [118in.]



Negative common pre-wired terminal
S type plug connector
Lead wire 3000mm [118in.]



Manifold fitting specification

With ϕ 4 fittings

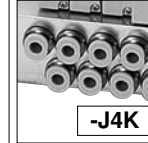

With ϕ 6 fittings



Individual air supply spacer

Without spacer

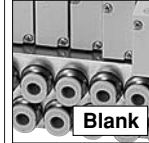

With individual
air supply spacer

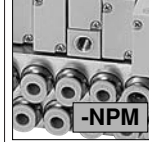

Back pressure prevention valve

Blank

Without back pressure
prevention valve

-E1

With back pressure
prevention valve

Voltage

-D4

DC24V

Model	Number of units	Station	Model	Valve specification	Manual override	Wiring specification	Manifold fitting specification	Back pressure prevention valve	Individual air supply spacer	Voltage									
Manifold model		Mounting valve model																	
CS-JAM	2 ⋮ 20	AJ	stn. 1 ⋮ stn. <input type="checkbox"/> Note	CS-JA10	Blank -83	-PN -PS -PS3 -CPS -CPS3 -MS -MS3 -CMS -CMS3	-J4K -J6K	Blank -E1	Blank -NPM	-D4									
				CS-JA10L															
				JABP (for block-off plate)															

Note: Valve mounting location is from the left, with the solenoid on top, and the 4(A) and 2(B) ports in front.

Additional Parts Order Codes for Monoblock Manifold

Manifold parts

CS - JAZ -

Parts description

- GS1 : Gasket
- E1 : Back pressure prevention valve
(2 pcs. for monoblock type)
- J4K : ϕ 4 fitting (2 pcs. for monoblock type,
and 1 pc. gasket)
- J6K : ϕ 6 fitting (2 pcs. for monoblock type,
and 1 pc. gasket)
- NPM : Individual air supply spacer
(Spacer body, gasket and 2 mounting screws)

Block-off plate (block-off plate and 2 mounting screws)

CS-JABP

Connector-related

CS - JAZ -

Connector specification

- CP : Positive common plug connector, lead wire length 300mm [11.8in.]
- CP3 : Positive common plug connector, lead wire length 3000mm [118in.]
- CPN : Positive common plug connector, without lead wire (short bar and contacts included)
- PA : Positive common A type, plug connector lead wire length 300mm [11.8in.]**
- PA3 : Positive common A type, plug connector lead wire length 3000mm [118in.]**
- PB : Positive common B type, plug connector lead wire length 300mm [11.8in.]**
- PB3 : Positive common B type, plug connector lead wire length 3000mm [118in.]**
- PC : Positive common C type, plug connector lead wire length 300mm [11.8in.]**
- PC3 : Positive common C type, plug connector lead wire length 3000mm [118in.]**
- CM : Negative common plug connector, lead wire length 300mm [11.8in.]
- CM3 : Negative common plug connector, lead wire length 3000mm [118in.]
- CMN : Negative common plug connector, without lead wire (short bar and contacts included)
- MA : Negative common A type, plug connector lead wire length 300mm [11.8in.]**
- MA3 : Negative common A type, plug connector lead wire length 3000mm [118in.]**
- MB : Negative common B type, plug connector lead wire length 300mm [11.8in.]**
- MB3 : Negative common B type, plug connector lead wire length 3000mm [118in.]**
- MC : Negative common C type, plug connector lead wire length 300mm [11.8in.]**
- MC3 : Negative common C type, plug connector lead wire length 3000mm [118in.]**

※ For details, see the Valves General Catalog.

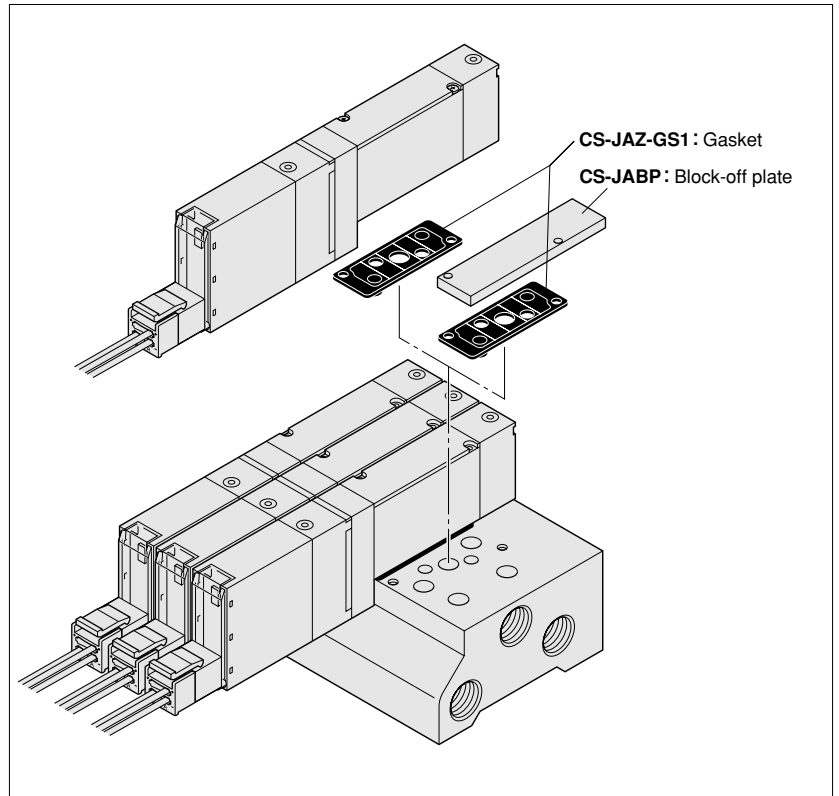

Manifold Order Code Example (6 units of JA series)

CS-JAM6AJ

- stn.1~2 CS-JA10A5-PS-J4K-D4
- stn.3~5 CS-JA10A6-PS-J6K-D4
- stn.6 CS-JABP-J6K

Note: This order code example has no relation to the illustration above.

Precautions for Order Codes

● Order for valves only

Place orders by "Single Valve Unit Order Codes" on p.185.

For common terminal wiring connections, order separately the common connector assemblies listed above.

Split Manifold Non-Plug-in Type Order Codes



Piping block specification (air supply and exhaust)

- JR: 1(P) and 3, 5(R) ports ϕ 8 fitting right-side mounting
- JL: 1(P) and 3, 5(R) ports ϕ 8 fitting left-side mounting
- JD: 1(P) and 3, 5(R) ports ϕ 8 fitting both-side mounting



The photo shows the -JR type.

- MR: 1(P) port ϕ 8 fitting, 3, 5(R) ports built-in muffler right-side mounting
- ML: 1(P) port ϕ 8 fitting, 3, 5(R) ports built-in muffler left-side mounting
- MD: 1(P) port ϕ 8 fitting, 3, 5(R) ports built-in muffler both-side mounting



The photo shows the -MR type.

Model

CS-JA10

Standard type

CS-JA10L

Low current type

Valve specification

- A1:** 2-port normally closed
- A2:** 2-port normally open
- A3:** 3-port normally closed
- A4:** 3-port normally open
- A5:** 5-port 2-position, single sol.
- A6:** 5-port 2-position, double sol.
- A7:** 3-position, closed center
- A8:** 3-position, exhaust center
- A9:** 3-position, pressure center
- AA:** Tandem 3-port (normally closed & normally closed)
- AB:** Tandem 3-port (normally open & normally open)
- AC:** Tandem 3-port (normally closed & normally open)

Model	Number of valve units	Manifold model	
CS-JAM	2 ⋮ 20	NJ	-JR -JL -JD -MR -ML -MD

Manual override

Non-locking type



Blank

Locking protruding type



-83

Wiring specification

S type plug connector
Without connector ass'y



-PN

Positive common
S type plug connector
Lead wire 300mm [11.8in.]



-PS

Negative common
S type plug connector
Lead wire 300mm [11.8in.]

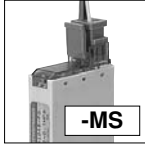

-MS

Positive common
S type plug connector
Lead wire 3000mm [118in.]



-PS3

Negative common
S type plug connector
Lead wire 3000mm [118in.]



-MS3

Positive common
pre-wired terminal
S type plug connector
Lead wire 300mm [11.8in.]

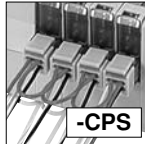

-CPS

Negative common
pre-wired terminal
S type plug connector
Lead wire 300mm [11.8in.]



-CMS

Positive common
pre-wired terminal
S type plug connector
Lead wire 3000mm [118in.]



-CPS3

Negative common
pre-wired terminal
S type plug connector
Lead wire 3000mm [118in.]



-CMS3

Manifold fitting specification

With ϕ 4 fittings

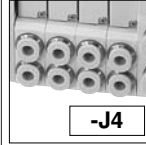

-J4

With ϕ 6 fittings

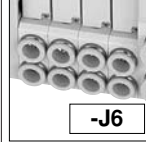

-J6

Individual air supply spacer

Without spacer

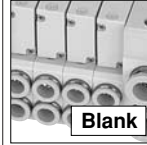

Blank

With individual air supply spacer

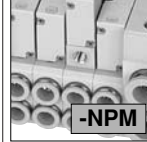

-NPM

Back pressure prevention valve

Blank

Without back pressure prevention valve

-E2

With back pressure prevention valve

Port isolator

Blank : Without port isolator
-S1 : For 1(P) port
-S3 : For 3(R2) and 5(R1) ports
-SA : For 1(P), 3(R2) and 5(R1) ports

Voltage

-D4

DC24V

Station	Model	Valve specification	Manual override	Wiring specification	Manifold fitting specification	Back pressure prevention valve	Individual air supply spacer	Port isolator	Voltage
---------	-------	---------------------	-----------------	----------------------	--------------------------------	--------------------------------	------------------------------	---------------	---------

Mounting valve model

stn. 1 ⋮ stn. □ Note1	CS-JA10 CS-JA10L	A1	Blank -83	-PN	-J4 -J6	Blank -E2	Blank -NPM	Blank -S1 ^{Note2} -S3 ^{Note2} -SA ^{Note2}	-D4
		A2		-PS					
		A3		-PS3					
		A4		-CPS					
		A5		-CPS3					
		A6		-MS					
		A7		-MS3					
		A8		-CMS					
		A9		-CMS3					
		AA							
		AB							
		AC							
JABP (for block-off plate)									

Notes: 1. Valve mounting location is from the left, with the solenoid on top, and the 4(A) and 2(B) ports in front.

2. Port isolators can be installed only when piping blocks are mounted on both sides. In addition, only 1 location for each port isolator can be installed in 1 manifold for -SA, or 1 each port isolator for -S1 and -S3 for a total of 2 locations. When shipping, the designated port isolators are installed between the designated station and the station to its immediate left (the next smaller stn. No.).

Additional Parts Order Codes for Split Manifold Non-Plug-in Type

Manifold parts

CS - JAZ -

Parts description

- GS2** : Gasket (for split type)
- E2** : Back pressure prevention valve (2 pcs. for split type and 1 pc. gasket)
- J4** : 2 pcs. ϕ 4 fittings, and 1 pc. stopper pin
- J6** : 2 pcs. ϕ 6 fittings, and 1 pc. stopper pin
- J8** : 2 pcs. ϕ 8 fittings, and 1 pc. stopper pin
- M** : Muffler for piping block
- NPM** : Individual air supply spacer (spacer body, gasket and 2 mounting screws)
- S1** : Port isolator for 1(P) port
- S3** : Port isolator for 3(R2) and 5(R1) ports
- SA** : Port isolator for 1(P) port, 3(R2) and 5(R1) ports

Block-off plate (block-off plate and 2 mounting screws)

CS - JABP

Piping block assembly

CS - JAZ -

Piping specification

- PJ** : 1(P) and 3, 5(R) ports ϕ 8 fittings
- PM** : 1(P) port ϕ 8 fitting, 3, 5(R) ports built-in mufflers

Connector-related

CS - JAZ -

Connector specification

- CP** :Positive common plug connector, lead wire length 300mm [11.8in.]
- CP3** :Positive common plug connector, lead wire length 3000mm [118in.]
- CPN** :Positive common plug connector, without lead wire (short bar and contacts included)
- PA** :Positive common A type, plug connector lead wire length 300mm [11.8in.]*
- PA3** :Positive common A type, plug connector lead wire length 3000mm [118in.]*
- PB** :Positive common B type, plug connector lead wire length 300mm [11.8in.]*
- PB3** :Positive common B type, plug connector lead wire length 3000mm [118in.]*
- PC** :Positive common C type, plug connector lead wire length 300mm [11.8in.]*
- PC3** :Positive common C type, plug connector lead wire length 3000mm [118in.]*
- CM** :Negative common plug connector, lead wire length 300mm [11.8in.]
- CM3** :Negative common plug connector, lead wire length 3000mm [118in.]
- CMN** :Negative common plug connector, without lead wire (short bar and contacts included)
- MA** :Negative common A type, plug connector lead wire length 300mm [11.8in.]*
- MA3** :Negative common A type, plug connector lead wire length 3000mm [118in.]*
- MB** :Negative common B type, plug connector lead wire length 300mm [11.8in.]*
- MB3** :Negative common B type, plug connector lead wire length 3000mm [118in.]*
- MC** :Negative common C type, plug connector lead wire length 300mm [11.8in.]*
- MC3** :Negative common C type, plug connector lead wire length 3000mm [118in.]*

*For details, see the Valves General Catalog.

End blocks (one set of left and right)

CS - JAZ - E

Valve base assembly (valve base and gasket)

CS - JAZ -

Piping specification

- VJ4** : With ϕ 4 fitting
- VJ6** : With ϕ 6 fitting

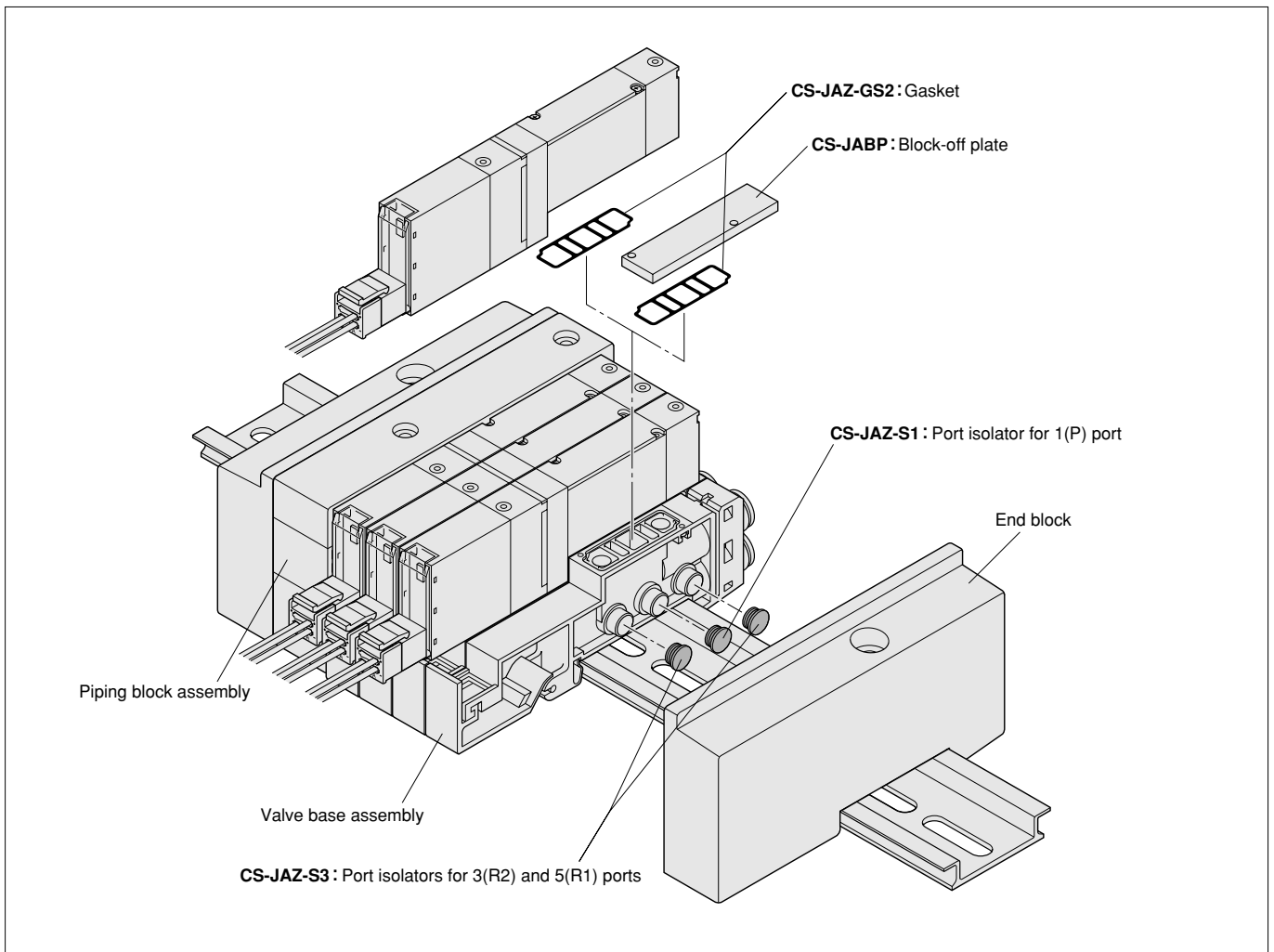

Manifold Order Code Example (6 units of JA series)

CS-JAM6NJ-JR

stn.1~2 CS-JA10A5-PS-J4-D4

stn.3~5 CS-JA10A6-PS-J6-D4

stn.6 CS-JABP-J6

Note: This order code example has no relation to the illustration above.

Precautions for Order Codes

● Order for valves only

Place orders by "Single Valve Unit Order Codes" on p.185.

For wiring specifications, **Blank** (plug-in type valve) cannot be selected.

For common terminal wiring connections, order separately the common connector assemblies listed to the left.

Split Manifold Plug-in Type Order Codes



Piping block specification (air supply and exhaust)

- JR: 1 (P) and 3, 5(R) ports ϕ 8 fitting right-side mounting
- JL: 1 (P) and 3, 5(R) ports ϕ 8 fitting left-side mounting
- JD: 1 (P) and 3, 5(R) ports ϕ 8 fitting both-side mounting



The photo shows the -JR type.

- MR: 1 (P) port ϕ 8 fitting, 3, 5(R) ports built-in muffler, right-side mounting
- ML: 1 (P) port ϕ 8 fitting, 3, 5(R) ports built-in muffler, left-side mounting
- MD: 1 (P) port ϕ 8 fitting, 3, 5(R) ports built-in muffler, both-side mounting



The photo shows the -MR type.

Wiring specification (wiring block)

Flat cable connector (with socket and strain relief)

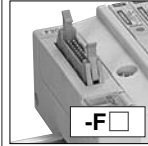

- F200: 20-pin (connector on upper side)
- F201: 20-pin (connector on upper side)
- F260: 26-pin (connector on upper side)

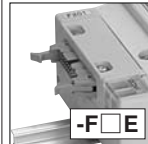

- F200E: 20-pin (connector on side)
- F201E: 20-pin (connector on side)
- F260E: 26-pin (connector on side)

D-sub connector (M2.6 mounting screw)



- D250: 25-pin (connector on upper side)
- D251: 25-pin (connector on upper side)



- D250E: 25-pin (connector on side)
- D251E: 25-pin (connector on side)

※ For details of wiring specification, see the Valves General Catalog.

Wiring connection specification

Blank

Packed wiring : Wiring is made in accordance with the mounted valve specifications.^{Note}

-D

Double wiring : Wiring is always the one for the double solenoid, regardless of the specifications of the mounted valve.^{Note}

Note: The wiring for the block-off plate is normally the one for the double solenoid. However, when -S is designated as the block-off plate wiring specification, the block-off plate wiring of the station is changed to the one for the single solenoid.

Pre-wired common

Blank

Positive common

-CM

Negative common

Voltage

-D4

DC24V

Model	Number of valve units	Piping block specification (air supply and exhaust)	Wiring specification	Wiring connection specification	pre-wired common	Voltage
Manifold model						
CS-JAM	2 ⋮ □ Note1	PJ	-JR -JL -JD -MR -ML -MD	-F200 -F201 -F260 -F200E -F201E -F260E -D250 -D251 -D250E -D251E	Blank -D	Blank -CM
						-D4

Notes: 1. For the maximum number of units, see the table for maximum number of valve units by wiring specification, on p.195.

Model

CS-JA10

Standard type

CS-JA10L

Low current type

Valve specification

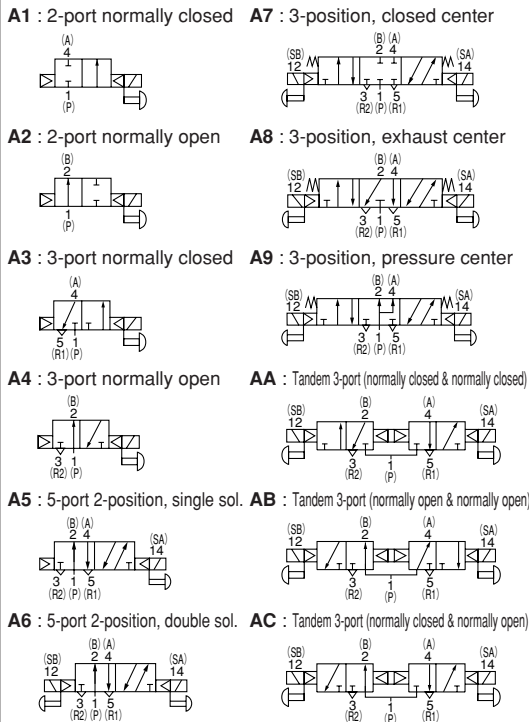

Manual override

Non-locking type

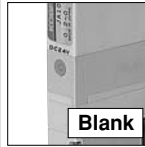

Locking protruding type



Manifold fitting specification

With ϕ 4 fittings

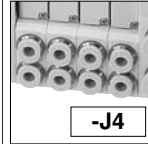

With ϕ 6 fittings

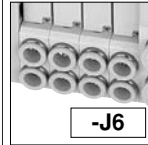

Back pressure prevention valve

Blank

Without back pressure prevention valve

-E2

With back pressure prevention valve

Individual air supply spacer

Without spacer

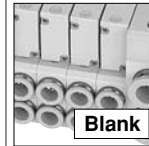

With individual air supply spacer

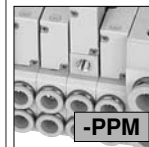

Port isolator

Blank : Without port isolator
-S1 : For 1(P) port
-S3 : For 3(R2) and 5(R1) ports
-SA : For 1(P), 3(R2) and 5(R1) ports

Block-off plate wiring specification

Blank

Wiring is always the one for the double solenoid.

-S

When **-S** is designated, the block-off plate wiring of the station is changed to the one for the single solenoid.

Voltage

-D4

DC24V

Station	Model	Valve specification	Manual override	Manifold fitting specification	Back pressure prevention valve	Individual air supply spacer	Port isolator	Block-off plate wiring specification	Voltage
---------	-------	---------------------	-----------------	--------------------------------	--------------------------------	------------------------------	---------------	--------------------------------------	---------

Mounting valve model

stn. 1 ⋮ stn. □ Note2	CS-JA10 CS-JA10L	A1 A2 A3 A4 A5 A6 A7 A8 A9 AA AB AC	Blank -83	-J4 -J6	Blank -E2	Blank -PPM	Blank -S1 ^{Note3} -S3 ^{Note3} -SA ^{Note3}	Blank -D4
	JABPP (for block-off plate)		Blank -S					

Notes: 2. Valve mounting location is from the left, with the solenoid on top, and the 4(A) and 2(B) ports in front.

3. Port isolators can be installed only when piping blocks are mounted on both sides. In addition, only 1 location of each port isolator can be installed in 1 manifold for **-SA**, or 1 each port isolator for **-S1** and **-S3**, for a total of 2 locations. When shipping, the designated port isolators are installed between the designated station and the station to its immediate left (the next smaller stn. No.).

Additional Parts Order Codes for Split Manifold Plug-in Type

Manifold parts

CS - JAZ -

Parts description

- GS2 : Gasket (for split type)
- E2 : Back pressure prevention valve (2 pcs. for split type, and 1 pc. gasket)
- J4 : 2 pcs. ϕ 4 fittings, and 1 pc. stopper pin
- J6 : 2 pcs. ϕ 6 fittings, and 1 pc. stopper pin
- J8 : 2 pcs. ϕ 8 fittings, and 1 pc. stopper pin
- M : Muffler for piping block
- PPM : Individual air supply spacer (spacer body, gasket, 2 mounting screws, and connector ass'y)
- S1 : Port isolator for 1(P) port
- S3 : Port isolator for 3(R2) and 5(R1) ports
- SA : Port isolator for 1(P) port, 3(R2) and 5(R1) ports

Block-off plate (block-off plate, 2 mounting screws, and plug)

CS - JABPP

Piping block assembly

CS - JAZ -

Piping specification

- PJ : 1(P) and 3, 5(R) ports ϕ 8 fittings
- PM : 1(P) port ϕ 8 fitting, 3, 5(R) ports built-in mufflers

Wiring block assembly (one set)

CS - JAZ - - -

Voltage
D4 : DC24V

Pre-wired common
Blank : Positive common
CM : Negative common

- Wiring specification**
- F200 : Flat cable connector
 - F201 : Flat cable connector
 - F260 : Flat cable connector
 - D250 : D-sub connector
 - D251 : D-sub connector

End blocks (one set of left and right)

CS - JAZ - EP

Valve base assembly (valve base, gasket, lead wire and plug-in connector)

CS - JAZ - - -

Pre-wired common
Blank : Positive common
CM : Negative common

Wiring specification
D : For D-sub connector
F : For flat cable connector

Piping specification
VJ4 : With ϕ 4 fitting
VJ6 : With ϕ 6 fitting

Table for maximum number of valve units by wiring specification

		Maximum number of units	
		Wiring connection specification	
Wiring specification	Max. outputs	Packed wiring (Blank)	Double wiring (-D)
F200 <input type="checkbox"/> Flat cable (20P)	16	Varies depending on the mounted number of single solenoids, double solenoids and block-off plates. The number of controllable solenoids should be the maximum number of outputs to the left or less.	8 units
F201 <input type="checkbox"/> Flat cable (20P)	16		8 units
F260 <input type="checkbox"/> Flat cable (26P)	20		10 units
D250 <input type="checkbox"/> D-sub connector (25P)	16		8 units
D251 <input type="checkbox"/> D-sub connector (25P)	20		10 units

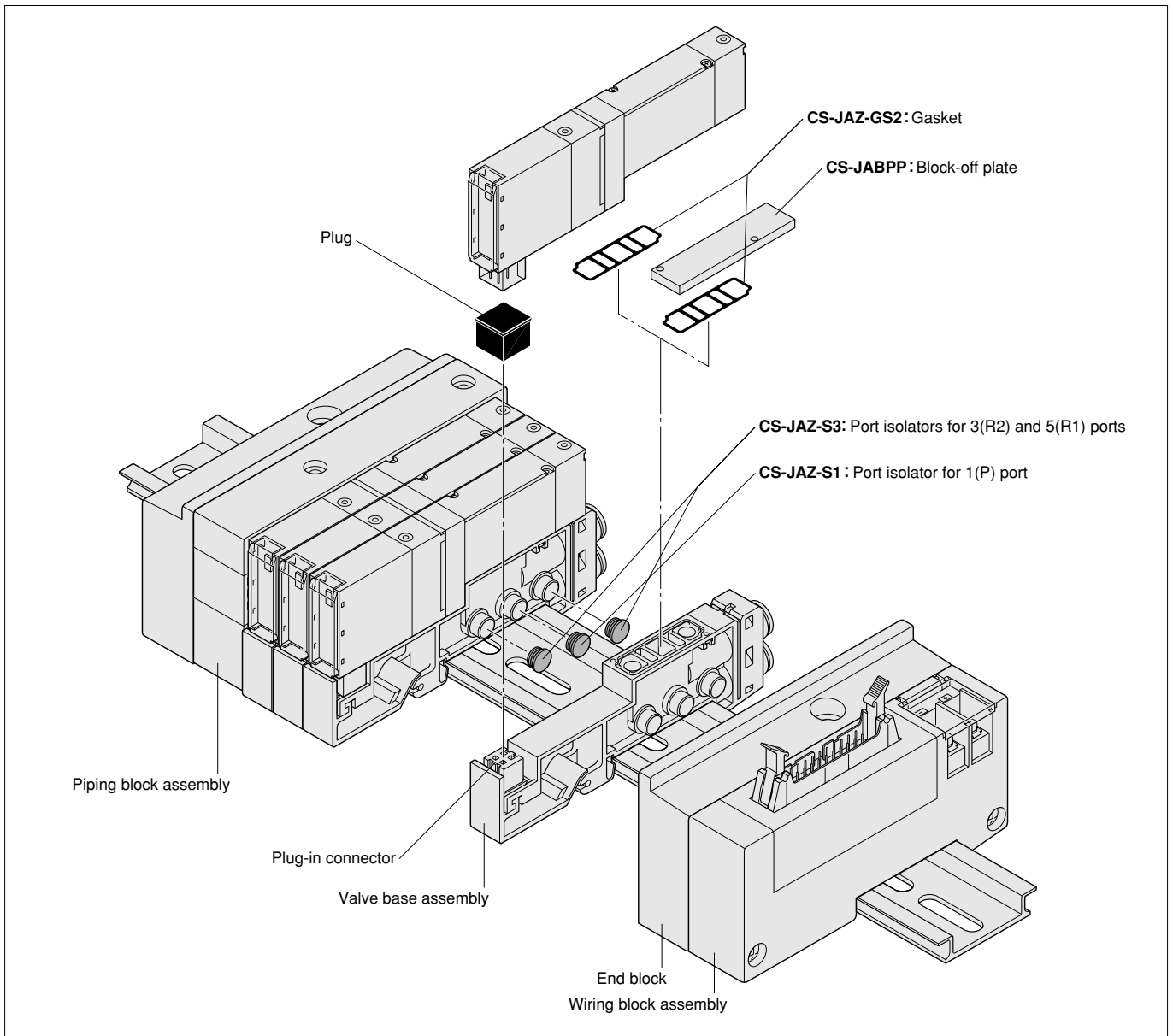

Manifold Order Code Example (8 units of JA series)

CS-JAM8PJ-JR-F201-D4

stn.1~4 CS-JA10A5-J4-D4

stn.5~7 CS-JA10A6-J6-D4

stn.8 CS-JABPP-J6

Note: This order code example has no relation to the illustration above.

Precautions for Order Codes

● Order for valves only

Place orders by "Single Valve Unit Order Codes" on p.185.

The wiring specification, however, is available on the **Blank** (plug-in type) only.

● Wiring connection specification

Blank (packed wiring) : Wiring is made in accordance with the mounted valve specifications.

-D (double wiring) : Wiring is always for the double solenoid, regardless of the mounted valve specifications.

Note: The wiring for the block-off plate is normally the one for the double solenoid. However, when **-S** is designated as the block-off plate wiring specification, the block-off plate wiring of the station is changed to the one for the single solenoid.

Serial Transmission Type Order Codes



Serial transmission block specification

※ These are serial transmission block specifications compatible with each system.



For details, see the Valves General Catalog.

- A1 : For Omron CompoBus/S (16 outputs)
- B1 : For Mitsubishi Electric CC-Link (16 outputs)
- B3 : For Mitsubishi Electric CC-Link (32 outputs)
- D1 : For DeviceNet (CompoBus/D)
- F1 : For SUNX S-LINK V (16 outputs)

Wiring connection specification

Blank

Packed wiring : Wiring is made in accordance with the mounted valve specifications.^{Note}

-D

Double wiring : Wiring is always the one for the double solenoid, regardless of the specifications of the mounted valve.^{Note}

Note: The wiring for the block-off plate is normally the one for the double solenoid. However, when -S is designated as the block-off plate wiring specification, the block-off plate wiring of the station is changed to the one for the single solenoid.

Piping block specification (air supply and exhaust)

- JR** : 1(P) and 3, 5(R) ports ϕ 8 fitting right-side mounting
- JL** : 1(P) and 3, 5(R) ports ϕ 8 fitting left-side mounting
- JD** : 1(P) and 3, 5(R) ports ϕ 8 fitting both-side mounting



The photo shows the -JR type.

- MR** : 1(P) port ϕ 8 fitting, 3, 5(R) ports built-in muffler right-side mounting
- ML** : 1(P) port ϕ 8 fitting, 3, 5(R) ports built-in muffler left-side mounting
- MD** : 1(P) port ϕ 8 fitting, 3, 5(R) ports built-in muffler both-side mounting



The photo shows the -MR type.

Model	Number of valve units	Piping block specification (air supply and exhaust)	Serial transmission block specification	Wiring connection specification
Manifold model				
CS-JAM	2 ⋮ □ Note1	SJ	-JR -JL -JD -MR -ML -MD	-A1 -B1 -B3 -D1 -F1 Blank -D

Notes: 1. For the maximum number of units, see the table for maximum number of valve units by serial transmission block specification, on p.199.

Model

CS-JA10

Standard type

CS-JA10L

Low current type

Valve specification

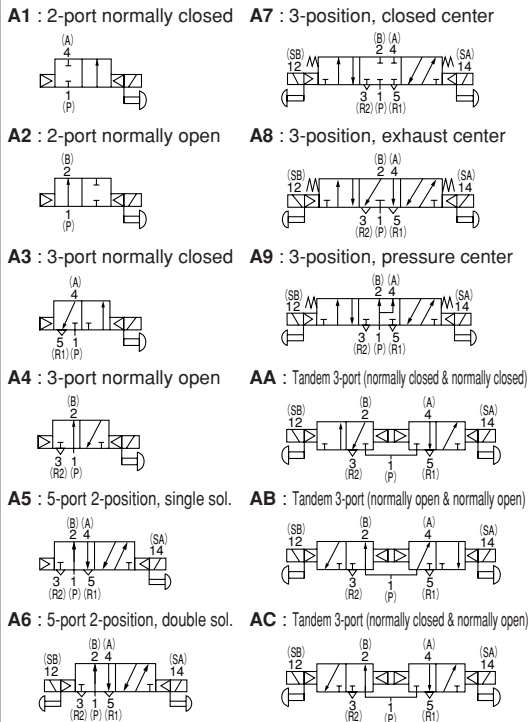

Manual override

Non-locking type

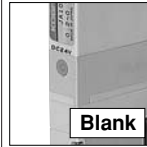

Locking protruding type

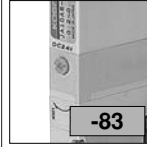

Manifold fitting specification

With ϕ 4 fittings

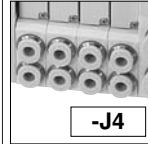

With ϕ 6 fittings

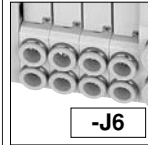

Back pressure prevention valve

Blank

Without back pressure prevention valve

-E2

With back pressure prevention valve

Individual air supply spacer

Without spacer

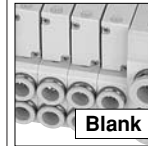

With individual air supply spacer

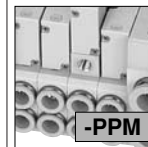

Port isolator

Blank : Without port isolator
-S1 : For 1(P) port
-S3 : For 3(R2) and 5(R1) ports
-SA : For 1(P), 3(R2) and 5(R1) ports

Block-off plate wiring specification

Blank

Wiring is always the one for the double solenoid.

-S

When **-S** is designated, the block-off plate wiring of the station is changed to the one for the single solenoid.

Voltage

-D4

DC24V

Station	Model	Valve specification	Manual override	Manifold fitting specification	Back pressure prevention valve	Individual air supply spacer	Port isolator	Block-off plate wiring specification	Voltage
---------	-------	---------------------	-----------------	--------------------------------	--------------------------------	------------------------------	---------------	--------------------------------------	---------

Mounting valve model

stn. 1 ⋮ stn. □ Note2	CS-JA10 CS-JA10L	A1 A2 A3 A4 A5 A6 A7 A8 A9 AA AB AC	Blank -83	-J4 -J6	Blank -E2	Blank -PPM	Blank -S1 ^{Note3} -S3 ^{Note3} -SA ^{Note3}	Blank -D4
	CS-JABPP (for block-off plate)						Blank -S	

Notes: 2. Valve mounting location is from the left, with the solenoid on top, and the 4(A) and 2(B) ports in front.

3. Port isolators can be installed only when piping blocks are mounted on both sides. In addition, only 1 location of each port isolator can be installed in 1 manifold for **-SA**, or 1 each port isolator for **-S1** and **-S3**, for a total of 2 locations. When shipping, the designated port isolators are installed between the designated station and the station to its immediate left (the next smaller stn. No.).

Additional Parts Order Codes for Serial Transmission Type

Manifold parts

CS - JAZ -

Parts description

- GS2 : Gasket (for split type)
- E2 : Back pressure prevention valve (2 pcs. for split type, and 1 pc. gasket)
- J4 : 2 pcs. ϕ 4 fittings, and 1 pc. stopper pin
- J6 : 2 pcs. ϕ 6 fittings, and 1 pc. stopper pin
- J8 : 2 pcs. ϕ 8 fittings, and 1 pc. stopper pin
- M : Muffler for piping block
- PPM : Individual air supply spacer (spacer body, gasket, 2 mounting screws, and connector ass'y)
- S1 : Port isolator for 1(P) port
- S3 : Port isolator for (R2) and 5(R1) ports
- SA : Port isolator for 1(P) port, 3(R2) and 5(R1) ports

Block-off plate (block-off plate, 2 mounting screws, and plug)

CS - JABPP

End blocks (one set of left and right)

CS - JAZ - EP

Valve base assembly (valve base, gasket, lead wire and plug-in connector)

CS - JAZ - - F

Piping specification

- VJ4 : With ϕ 4 fitting
- VJ6 : With ϕ 6 fitting

Piping block assembly

CS - JAZ -

Piping specification

- PJ : 1(P) and 3, 5(R) ports ϕ 8 fittings
- PM : 1(P) port ϕ 8 fitting, 3, 5(R) ports built-in mufflers

Serial transmission block (single unit)

CS - YS5

Options

- Blank: For replacement of JA Series serial transmission block
 - U : With flat cable (general purpose type) ^{Note} compatible with F201
- Note: For general purpose type, see the Valves General Catalog.

Serial transmission block specification

- A1 : For Omron CompoBus/S (16 outputs)
- B1 : For Mitsubishi Electric CC-Link (16 outputs)
- B3 : For Mitsubishi Electric CC-Link (32 outputs)
- D1 : For DeviceNet (CompoBus/D)
- F1 : For SUNX S-LINK V (16 outputs)

Table for maximum number of valve units by serial transmission block specification

Transmission block specification		Maximum number of units	
		Wiring connection specification	
	Max. outputs	Packed wiring (Blank)	Double wiring (-D)
A1 : For Omron CompoBus/S (16 outputs)	16	Varies depending on the mounted number of single solenoids, double solenoids and block-off plates. The number of controllable solenoids should be the maximum number of outputs to the left or less.	8 units
B1 : For Mitsubishi Electric CC-Link (16 outputs)	16		8 units
B3 : For Mitsubishi Electric CC-Link (32 outputs)	32		16 units
D1 : For DeviceNet (CompoBus/D)	16		8 units
F1 : For SUNX S-LINK V (16 outputs)	16		8 units

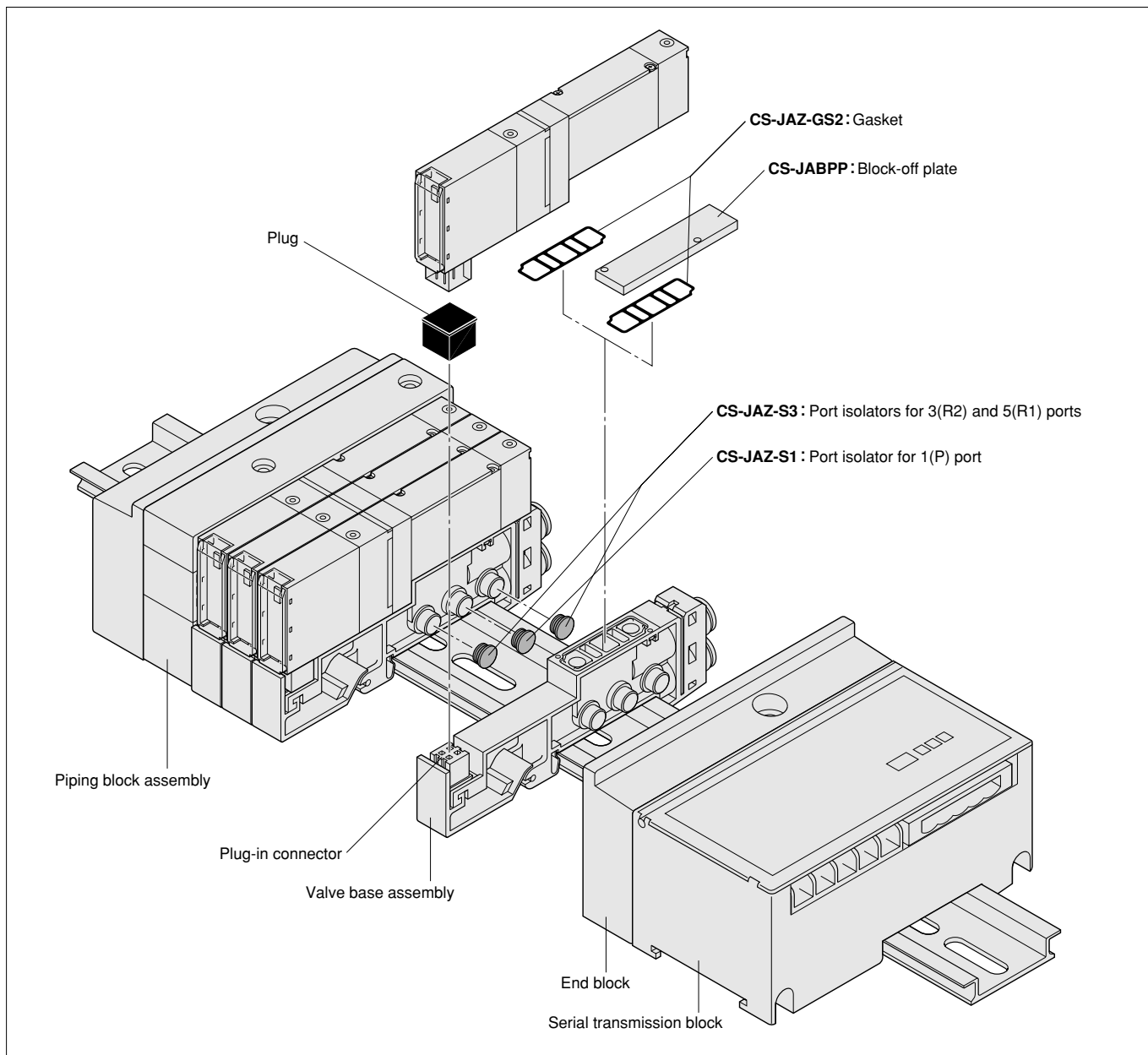

Manifold Order Code Example (8 units of JA series)

CS-JAM8SJ-JR-A1

stn.1~4 CS-JA10A5-J4-D4

stn.5~7 CS-JA10A6-J6-D4

stn.8 CS-JABPP-J6

Note: This order code example has no relation to the illustration above.

Precautions for Order Codes

● Order for valves only

Place orders by "Single Valve Unit Order Codes" on p.185.

The wiring specification, however, is compatible with the **Blank** (plug-in type) only.

● Wiring connection specification

Blank (packed wiring) : Wiring is made in accordance with the mounted valve specifications.

-D (double wiring) : Wiring is always for the double solenoid, regardless of the mounted valve specifications.

Note: The wiring for the block-off plate is normally the one for the double solenoid. However, when **-S** is designated as the block-off plate wiring specification, the block-off plate wiring of the station is changed to the one for the single solenoid.

Dimensions of JA Series Solenoid Valve mm [in.]

2-, 3-port, single solenoid

CS-JA10 □ **A1** - □ -PS

CS-JA10 □ **A2** - □ -PS

CS-JA10 □ **A3** - □ -PS

CS-JA10 □ **A4** - □ -PS

S type plug connector

Caution:

A1 : For 2-port normally closed type, plugged 2(B)

A2 : For 2-port normally open type, plugged 4(A)

A3 : For 3-port normally closed type, plugged 2(B)

A4 : For 3-port normally open type, plugged 4(A)

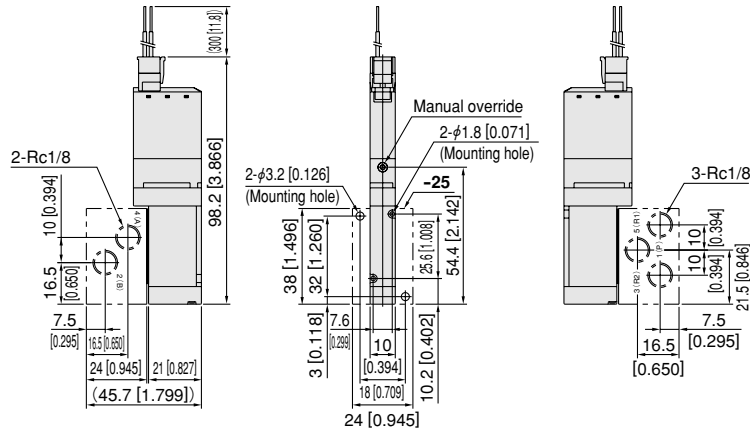

5-port, single solenoid

CS-JA10 □ **A5** - □ -PS

S type plug connector

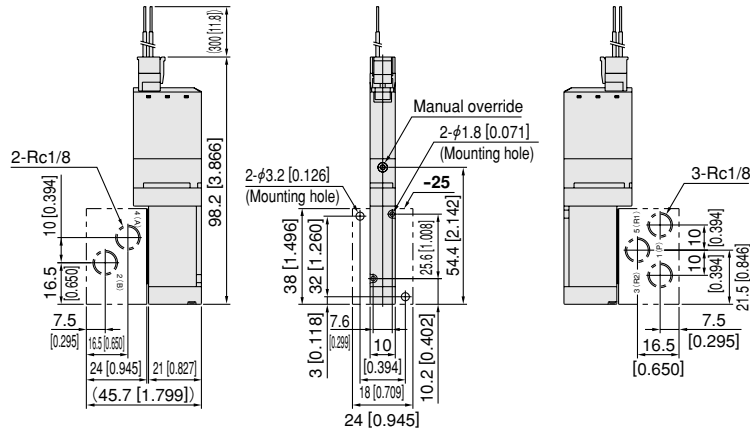

5-port, double solenoid

CS-JA10 □ **A6** - □ -PS

S type plug connector

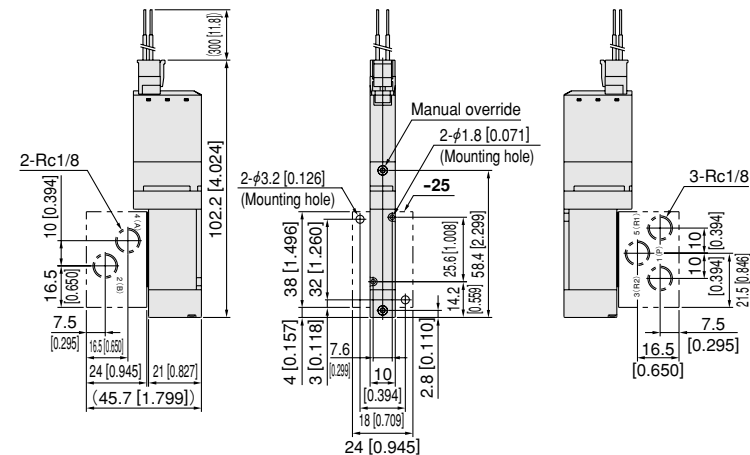

Options

● Locking protruding type manual override : -83

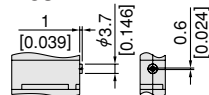

For single solenoid

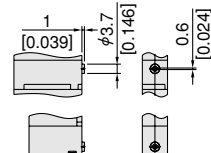

For double solenoid

Dimensions of JA Series Solenoid Valve mm [in.]

5-port, 3-position

CS-JA10 □ **A7**-□-PS

CS-JA10 □ **A8**-□-PS

CS-JA10 □ **A9**-□-PS

S type plug connector

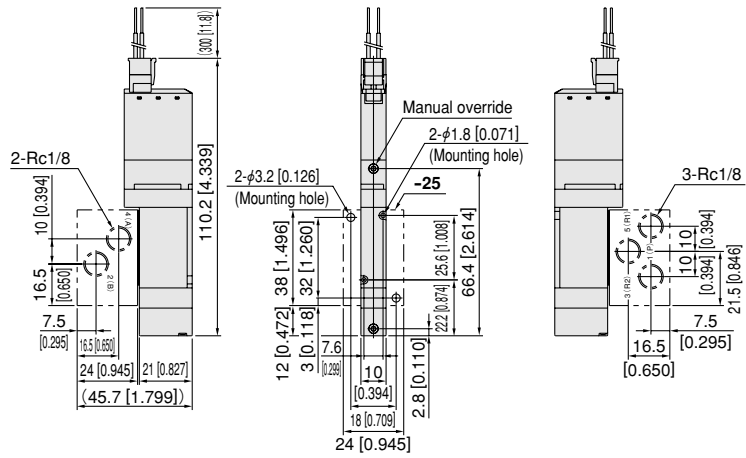

Tandem 3-port, 4-position

CS-JA10 □ **AA**-□-PS

CS-JA10 □ **AB**-□-PS

CS-JA10 □ **AC**-□-PS

S type plug connector

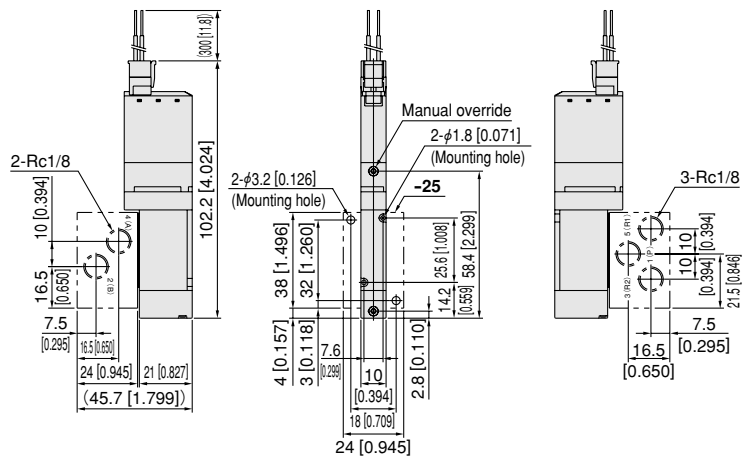

Option

● Locking protruding type manual override : **-83**

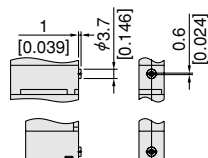

Dimensions of JA Series Monoblock Manifold mm [in.]

CS-JAM AJ

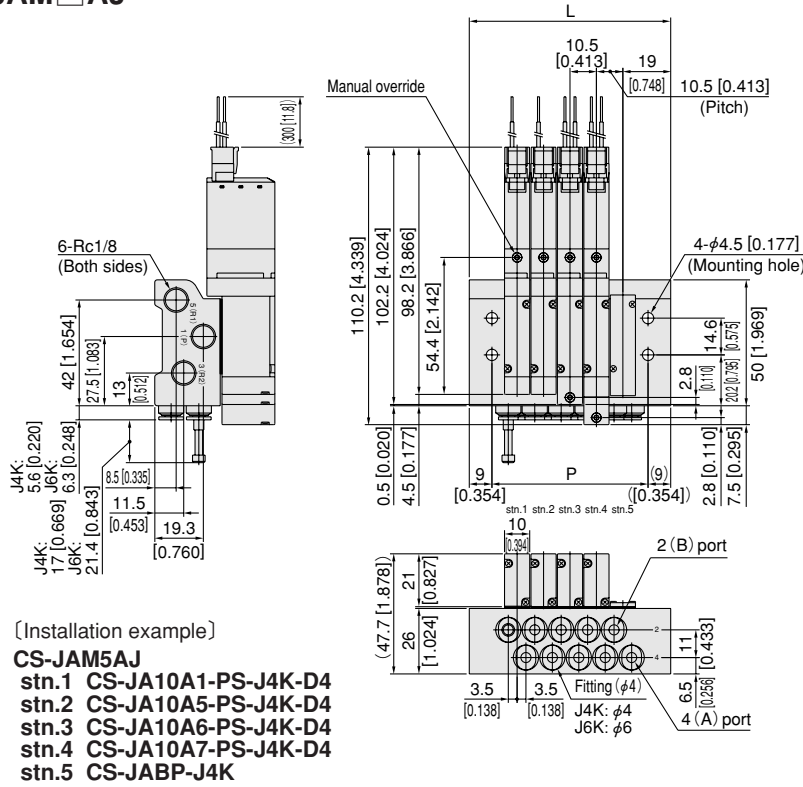

Unit dimensions

No. of units	L	P
2	48.5 [1.909]	30.5 [1.201]
3	59.0 [2.323]	41.0 [1.614]
4	69.5 [2.736]	51.5 [2.028]
5	80.0 [3.150]	62.0 [2.441]
6	90.5 [3.563]	72.5 [2.854]
7	101.0 [3.976]	83.0 [3.268]
8	111.5 [4.390]	93.5 [3.681]
9	122.0 [4.803]	104.0 [4.094]
10	132.5 [5.217]	114.5 [4.508]
11	143.0 [5.630]	125.0 [4.921]
12	153.5 [6.043]	135.5 [5.335]
13	164.0 [6.457]	146.0 [5.748]
14	174.5 [6.870]	156.5 [6.161]
15	185.0 [7.283]	167.0 [6.575]
16	195.5 [7.697]	177.5 [6.988]
17	206.0 [8.110]	188.0 [7.402]
18	216.5 [8.524]	198.5 [7.815]
19	227.0 [8.937]	209.0 [8.228]
20	237.5 [9.350]	219.5 [8.642]

Dimensions of JA Series Split Manifold Non-Plug-in Type mm [in.]

CS-JAM NJ

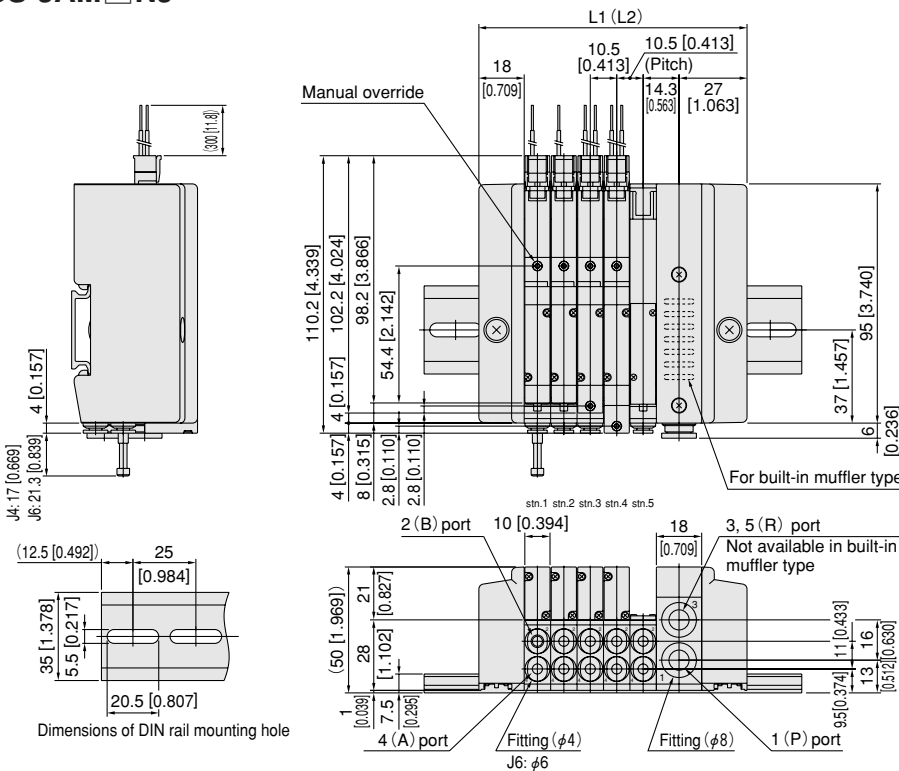

Unit dimensions

Number of units	L1	DIN rail length	L2 ^{Note}	DIN rail length ^{Note}
2	75.0 [2.953]	125 [4.921]	93.0 [3.661]	125 [4.921]
3	85.5 [3.366]	125 [4.921]	103.5 [4.075]	150 [5.906]
4	96.0 [3.780]	125 [4.921]	114.0 [4.488]	150 [5.906]
5	106.5 [4.193]	150 [5.906]	124.5 [4.902]	175 [6.890]
6	117.0 [4.606]	150 [5.906]	135.0 [5.315]	175 [6.890]
7	127.5 [5.020]	175 [6.890]	145.5 [5.728]	175 [6.890]
8	138.0 [5.433]	175 [6.890]	156.0 [6.142]	200 [7.874]
9	148.5 [5.846]	200 [7.874]	166.5 [6.555]	200 [7.874]
10	159.0 [6.260]	200 [7.874]	177.0 [6.969]	225 [8.858]
11	169.5 [6.673]	200 [7.874]	187.5 [7.382]	225 [8.858]
12	180.0 [7.087]	225 [8.858]	198.0 [7.795]	250 [9.843]
13	190.5 [7.500]	225 [8.858]	208.5 [8.209]	250 [9.843]
14	201.0 [7.913]	250 [9.843]	219.0 [8.622]	250 [9.843]
15	211.5 [8.327]	250 [9.843]	229.5 [9.035]	275 [10.827]
16	222.0 [8.740]	275 [10.827]	240.0 [9.449]	275 [10.827]
17	232.5 [9.154]	275 [10.827]	250.5 [9.862]	300 [11.811]
18	243.0 [9.567]	275 [10.827]	261.0 [10.276]	300 [11.811]
19	253.5 [9.980]	300 [11.811]	271.5 [10.689]	325 [12.795]
20	264.0 [10.394]	300 [11.811]	282.0 [11.102]	325 [12.795]

Note : When using 2 piping blocks.

Dimensions of JA Series Split Manifold Plug-in Type mm [in.]

CS-JAM□PJ

Flat cable connector 20-pin
Connector on upper side specification

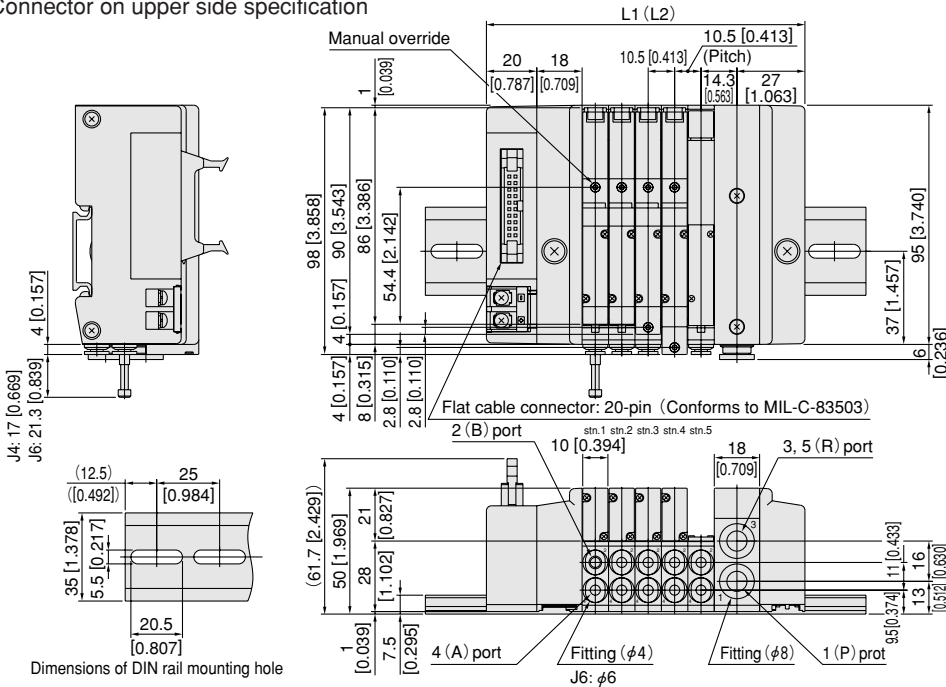

(Installation example)

- CS-JAM5PJ-JR-F20□-D4**
- stn.1 CS-JA10A1-J4-D4
- stn.2 CS-JA10A5-J4-D4
- stn.3 CS-JA10A6-J4-D4
- stn.4 CS-JA10A7-J4-D4
- stn.5 CS-JABPP-J4

Unit dimensions

Number of units	L1	DIN rail length	L2 ^{Note}	DIN rail length ^{Note}
2	95.0 [3.740]	150 [5.906]	113.0 [4.449]	175 [6.890]
3	105.5 [4.154]	175 [6.890]	123.5 [4.862]	175 [6.890]
4	116.0 [4.567]	175 [6.890]	134.0 [5.276]	200 [7.874]
5	126.5 [4.980]	175 [6.890]	144.5 [5.689]	200 [7.874]
6	137.0 [5.394]	200 [7.874]	155.0 [6.102]	200 [7.874]
7	147.5 [5.807]	200 [7.874]	165.5 [6.516]	225 [8.858]
8	158.0 [6.220]	225 [8.858]	176.0 [6.929]	225 [8.858]
9	168.5 [6.634]	225 [8.858]	186.5 [7.343]	250 [9.843]
10	179.0 [7.047]	225 [8.858]	197.0 [7.756]	250 [9.843]
11	189.5 [7.461]	250 [9.843]	207.5 [8.169]	275 [10.827]
12	200.0 [7.874]	250 [9.843]	218.0 [8.583]	275 [10.827]
13	210.5 [8.287]	275 [10.827]	228.5 [8.996]	275 [10.827]
14	221.0 [8.701]	275 [10.827]	239.0 [9.409]	300 [11.811]
15	231.5 [9.114]	300 [11.811]	249.5 [9.823]	300 [11.811]
16	242.0 [9.528]	300 [11.811]	260.0 [10.236]	325 [12.795]

Note : When using 2 piping blocks.

CS-JAM□PJ

Flat cable connector 20-pin
Connector on side specification

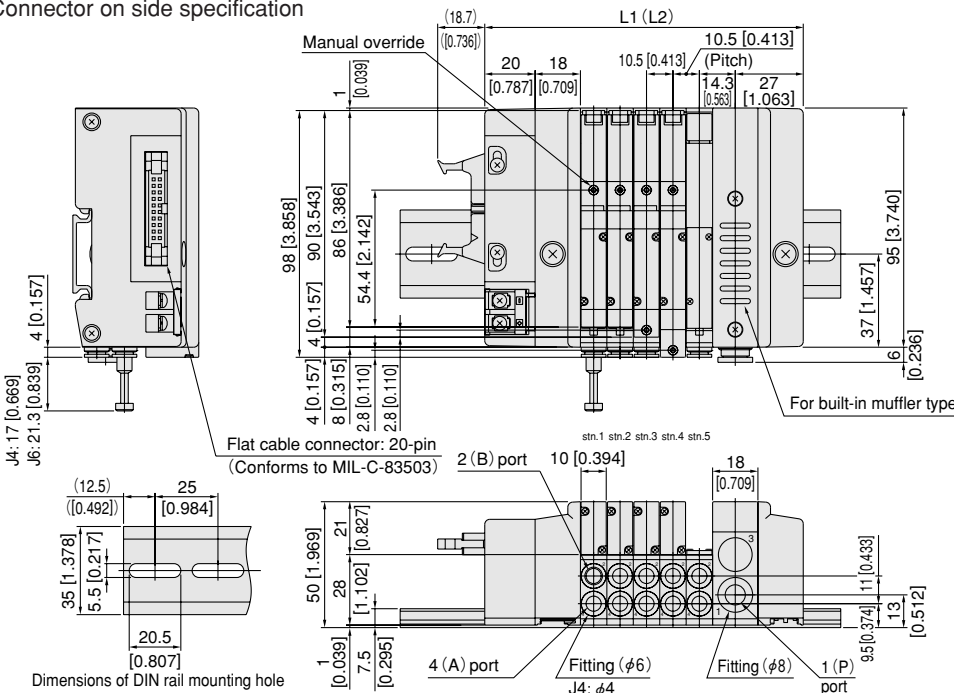

(Installation example)

- CS-JAM5PJ-MR-F20□-E-D4**
- stn.1 CS-JA10A1-J6-D4
- stn.2 CS-JA10A5-J6-D4
- stn.3 CS-JA10A6-J6-D4
- stn.4 CS-JA10A7-J6-D4
- stn.5 CS-JABPP-J6

Unit dimensions

Number of units	L1	DIN rail length	L2 ^{Note}	DIN rail length ^{Note}
2	95.0 [3.740]	150 [5.906]	113.0 [4.449]	175 [6.890]
3	105.5 [4.154]	175 [6.890]	123.5 [4.862]	175 [6.890]
4	116.0 [4.567]	175 [6.890]	134.0 [5.276]	200 [7.874]
5	126.5 [4.980]	175 [6.890]	144.5 [5.689]	200 [7.874]
6	137.0 [5.394]	200 [7.874]	155.0 [6.102]	200 [7.874]
7	147.5 [5.807]	200 [7.874]	165.5 [6.516]	225 [8.858]
8	158.0 [6.220]	225 [8.858]	176.0 [6.929]	225 [8.858]
9	168.5 [6.634]	225 [8.858]	186.5 [7.343]	250 [9.843]
10	179.0 [7.047]	225 [8.858]	197.0 [7.756]	250 [9.843]
11	189.5 [7.461]	250 [9.843]	207.5 [8.169]	275 [10.827]
12	200.0 [7.874]	250 [9.843]	218.0 [8.583]	275 [10.827]
13	210.5 [8.287]	275 [10.827]	228.5 [8.996]	275 [10.827]
14	221.0 [8.701]	275 [10.827]	239.0 [9.409]	300 [11.811]
15	231.5 [9.114]	300 [11.811]	249.5 [9.823]	300 [11.811]
16	242.0 [9.528]	300 [11.811]	260.0 [10.236]	325 [12.795]

Note : When using 2 piping blocks.

Dimensions of JA Series Split Manifold Plug-in Type mm [in.]

CS-JAM□PJ

Flat cable connector 26-pin
Connector on upper side specification

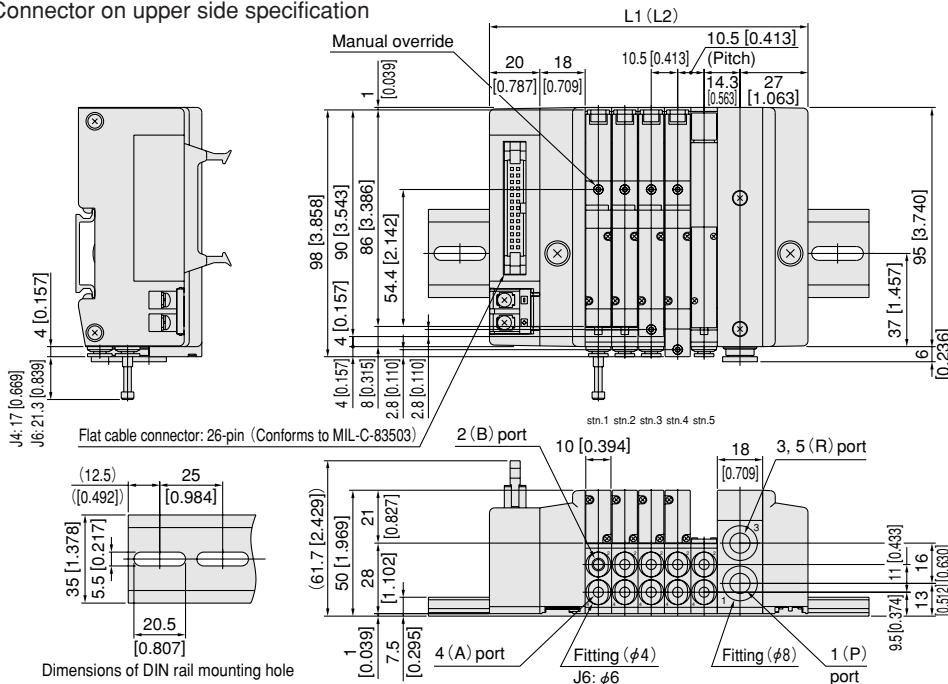

Dimensions of DIN rail mounting hole

[Installation example]

CS-JAM5PJ-JR-F260-D4
 stn.1 CS-JA10A1-J4-D4
 stn.2 CS-JA10A5-J4-D4
 stn.3 CS-JA10A6-J4-D4
 stn.4 CS-JA10A7-J4-D4
 stn.5 CS-JABPP-J4

Unit dimensions

Number of units	L1	DIN rail length	L2 ^{Note}	DIN rail length ^{Note}
2	95.0 [3.740]	150 [5.906]	113.0 [4.449]	175 [6.890]
3	105.5 [4.154]	175 [6.890]	123.5 [4.862]	175 [6.890]
4	116.0 [4.567]	175 [6.890]	134.0 [5.276]	200 [7.874]
5	126.5 [4.980]	175 [6.890]	144.5 [5.689]	200 [7.874]
6	137.0 [5.394]	200 [7.874]	155.0 [6.102]	200 [7.874]
7	147.5 [5.807]	200 [7.874]	165.5 [6.516]	225 [8.858]
8	158.0 [6.220]	225 [8.858]	176.0 [6.929]	225 [8.858]
9	168.5 [6.634]	225 [8.858]	186.5 [7.343]	250 [9.843]
10	179.0 [7.047]	225 [8.858]	197.0 [7.756]	250 [9.843]
11	189.5 [7.461]	250 [9.843]	207.5 [8.169]	275 [10.827]
12	200.0 [7.874]	250 [9.843]	218.0 [8.583]	275 [10.827]
13	210.5 [8.287]	275 [10.827]	228.5 [8.996]	275 [10.827]
14	221.0 [8.701]	275 [10.827]	239.0 [9.409]	300 [11.811]
15	231.5 [9.114]	300 [11.811]	249.5 [9.823]	300 [11.811]
16	242.0 [9.528]	300 [11.811]	260.0 [10.236]	325 [12.795]
17	252.5 [9.941]	300 [11.811]	270.5 [10.650]	325 [12.795]
18	263.0 [10.354]	325 [12.795]	281.0 [11.063]	350 [13.780]
19	273.5 [10.768]	325 [12.795]	291.5 [11.476]	350 [13.780]
20	284.0 [11.181]	350 [13.780]	302.0 [11.890]	350 [13.780]

Note : When using 2 piping blocks.

CS-JAM□PJ

Flat cable connector 26-pin
Connector on side specification

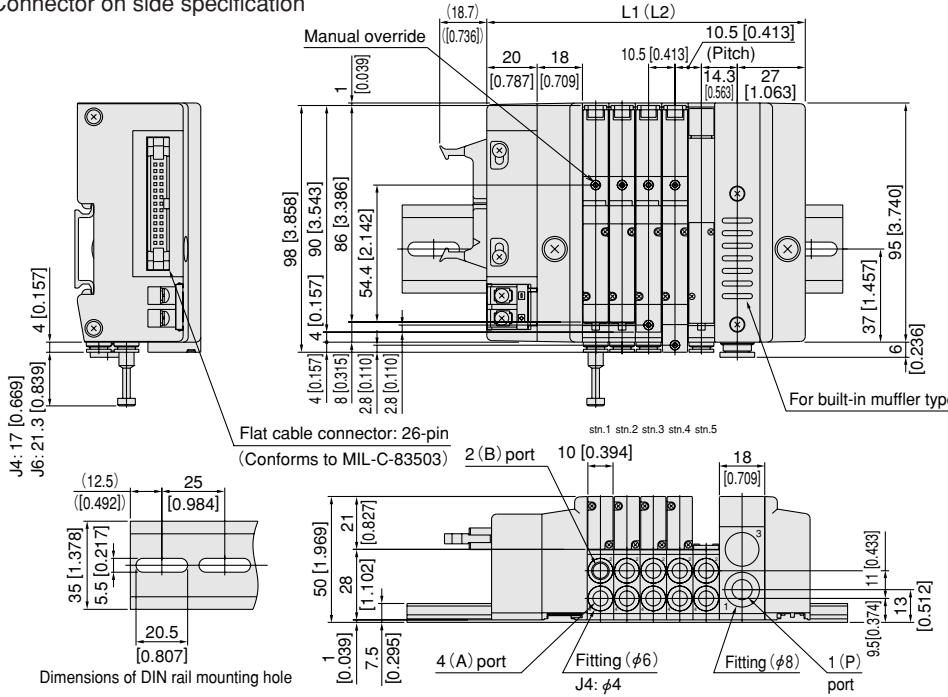

Dimensions of DIN rail mounting hole

[Installation example]

CS-JAM5PJ-MR-F260E-D4
 stn.1 CS-JA10A1-J6-D4
 stn.2 CS-JA10A5-J6-D4
 stn.3 CS-JA10A6-J6-D4
 stn.4 CS-JA10A7-J6-D4
 stn.5 CS-JABPP-J6

Unit dimensions

Number of units	L1	DIN rail length	L2 ^{Note}	DIN rail length ^{Note}
2	95.0 [3.740]	150 [5.906]	113.0 [4.449]	175 [6.890]
3	105.5 [4.154]	175 [6.890]	123.5 [4.862]	175 [6.890]
4	116.0 [4.567]	175 [6.890]	134.0 [5.276]	200 [7.874]
5	126.5 [4.980]	175 [6.890]	144.5 [5.689]	200 [7.874]
6	137.0 [5.394]	200 [7.874]	155.0 [6.102]	200 [7.874]
7	147.5 [5.807]	200 [7.874]	165.5 [6.516]	225 [8.858]
8	158.0 [6.220]	225 [8.858]	176.0 [6.929]	225 [8.858]
9	168.5 [6.634]	225 [8.858]	186.5 [7.343]	250 [9.843]
10	179.0 [7.047]	225 [8.858]	197.0 [7.756]	250 [9.843]
11	189.5 [7.461]	250 [9.843]	207.5 [8.169]	275 [10.827]
12	200.0 [7.874]	250 [9.843]	218.0 [8.583]	275 [10.827]
13	210.5 [8.287]	275 [10.827]	228.5 [8.996]	275 [10.827]
14	221.0 [8.701]	275 [10.827]	239.0 [9.409]	300 [11.811]
15	231.5 [9.114]	300 [11.811]	249.5 [9.823]	300 [11.811]
16	242.0 [9.528]	300 [11.811]	260.0 [10.236]	325 [12.795]
17	252.5 [9.941]	300 [11.811]	270.5 [10.650]	325 [12.795]
18	263.0 [10.354]	325 [12.795]	281.0 [11.063]	350 [13.780]
19	273.5 [10.768]	325 [12.795]	291.5 [11.476]	350 [13.780]
20	284.0 [11.181]	350 [13.780]	302.0 [11.890]	350 [13.780]

Note : When using 2 piping blocks.

Dimensions of JA Series Split Manifold Plug-in Type mm [in.]

CS-JAM□PJ

D-sub connector 25-pin
Connector on upper side specification

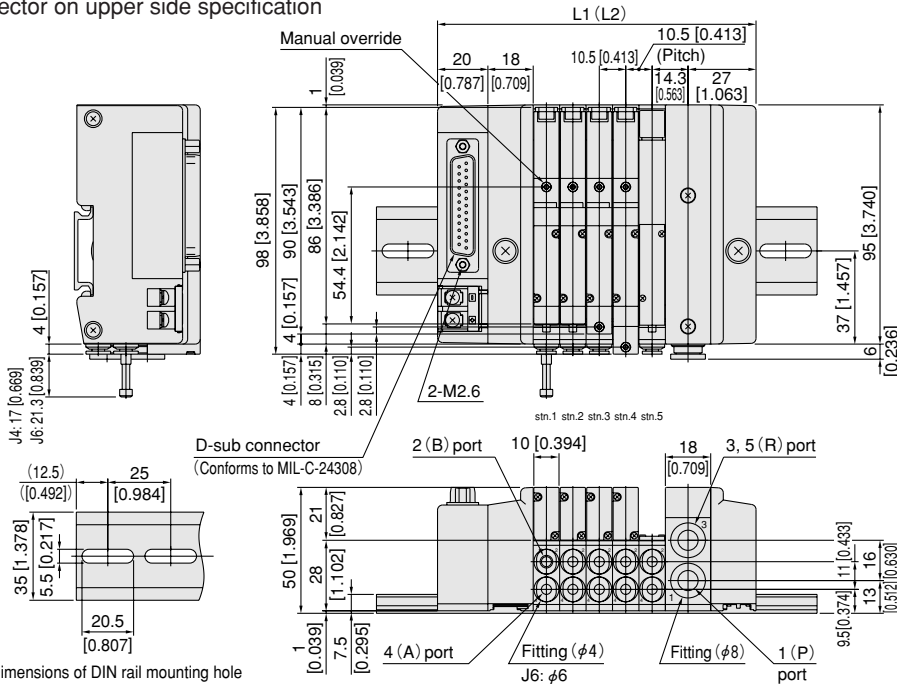

Dimensions of DIN rail mounting hole

[Installation example]

- CS-JAM5PJ-JR-D25□-D4**
- stn.1 CS-JA10A1-J4-D4
- stn.2 CS-JA10A5-J4-D4
- stn.3 CS-JA10A6-J4-D4
- stn.4 CS-JA10A7-J4-D4
- stn.5 CS-JABPP-J4

Unit dimensions

Number of units	L1	DIN rail length	L2 ^{Note}	DIN rail length ^{Note}
2	95.0 [3.740]	150 [5.906]	113.0 [4.449]	175 [6.890]
3	105.5 [4.154]	175 [6.890]	123.5 [4.862]	175 [6.890]
4	116.0 [4.567]	175 [6.890]	134.0 [5.276]	200 [7.874]
5	126.5 [4.980]	175 [6.890]	144.5 [5.689]	200 [7.874]
6	137.0 [5.394]	200 [7.874]	155.0 [6.102]	200 [7.874]
7	147.5 [5.807]	200 [7.874]	165.5 [6.516]	225 [8.858]
8	158.0 [6.220]	225 [8.858]	176.0 [6.929]	225 [8.858]
9	168.5 [6.634]	225 [8.858]	186.5 [7.343]	250 [9.843]
10	179.0 [7.047]	225 [8.858]	197.0 [7.756]	250 [9.843]
11	189.5 [7.461]	250 [9.843]	207.5 [8.169]	275 [10.827]
12	200.0 [7.874]	250 [9.843]	218.0 [8.583]	275 [10.827]
13	210.5 [8.287]	275 [10.827]	228.5 [8.996]	275 [10.827]
14	221.0 [8.701]	275 [10.827]	239.0 [9.409]	300 [11.811]
15	231.5 [9.114]	300 [11.811]	249.5 [9.823]	300 [11.811]
16	242.0 [9.528]	300 [11.811]	260.0 [10.236]	325 [12.795]
17	252.5 [9.941]	300 [11.811]	270.5 [10.650]	325 [12.795]
18	263.0 [10.354]	325 [12.795]	281.0 [11.063]	350 [13.780]
19	273.5 [10.768]	325 [12.795]	291.5 [11.476]	350 [13.780]
20	284.0 [11.181]	350 [13.780]	302.0 [11.890]	350 [13.780]

Note : When using 2 piping blocks.

CS-JAM□PJ

D-sub connector 25-pin
Connector on side specification

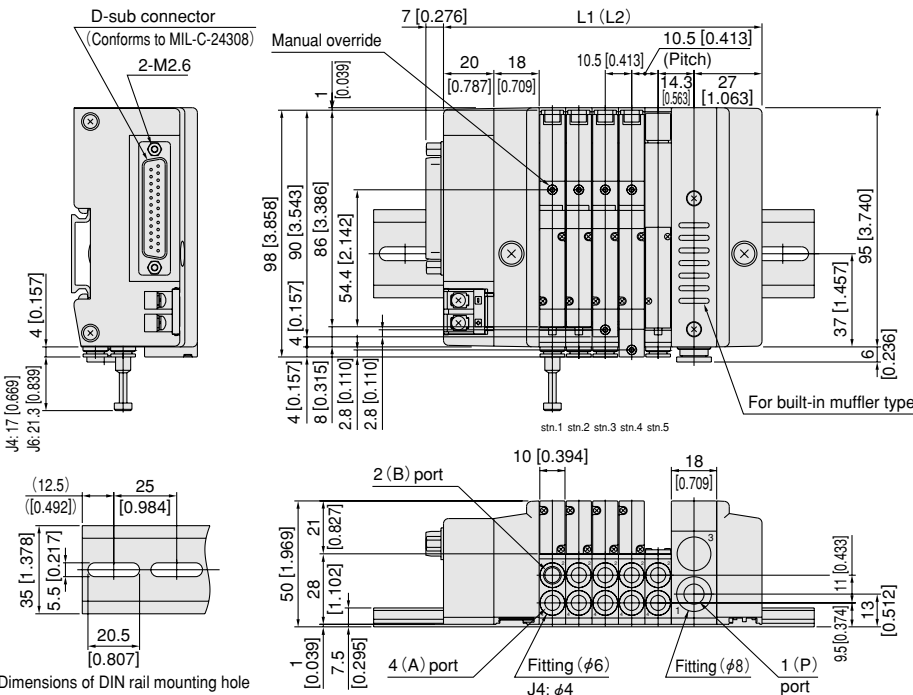

Dimensions of DIN rail mounting hole

[Installation example]

- CS-JAM5PJ-MR-D25□-E-D4**
- stn.1 CS-JA10A1-J6-D4
- stn.2 CS-JA10A5-J6-D4
- stn.3 CS-JA10A6-J6-D4
- stn.4 CS-JA10A7-J6-D4
- stn.5 CS-JABPP-J6

Unit dimensions

Number of units	L1	DIN rail length	L2 ^{Note}	DIN rail length ^{Note}
2	95.0 [3.740]	150 [5.906]	113.0 [4.449]	175 [6.890]
3	105.5 [4.154]	175 [6.890]	123.5 [4.862]	175 [6.890]
4	116.0 [4.567]	175 [6.890]	134.0 [5.276]	200 [7.874]
5	126.5 [4.980]	175 [6.890]	144.5 [5.689]	200 [7.874]
6	137.0 [5.394]	200 [7.874]	155.0 [6.102]	200 [7.874]
7	147.5 [5.807]	200 [7.874]	165.5 [6.516]	225 [8.858]
8	158.0 [6.220]	225 [8.858]	176.0 [6.929]	225 [8.858]
9	168.5 [6.634]	225 [8.858]	186.5 [7.343]	250 [9.843]
10	179.0 [7.047]	225 [8.858]	197.0 [7.756]	250 [9.843]
11	189.5 [7.461]	250 [9.843]	207.5 [8.169]	275 [10.827]
12	200.0 [7.874]	250 [9.843]	218.0 [8.583]	275 [10.827]
13	210.5 [8.287]	275 [10.827]	228.5 [8.996]	275 [10.827]
14	221.0 [8.701]	275 [10.827]	239.0 [9.409]	300 [11.811]
15	231.5 [9.114]	300 [11.811]	249.5 [9.823]	300 [11.811]
16	242.0 [9.528]	300 [11.811]	260.0 [10.236]	325 [12.795]
17	252.5 [9.941]	300 [11.811]	270.5 [10.650]	325 [12.795]
18	263.0 [10.354]	325 [12.795]	281.0 [11.063]	350 [13.780]
19	273.5 [10.768]	325 [12.795]	291.5 [11.476]	350 [13.780]
20	284.0 [11.181]	350 [13.780]	302.0 [11.890]	350 [13.780]

Note : When using 2 piping blocks.

Dimensions of JA Series Serial Transmission Type mm [in.]

CS-JAM□SJ

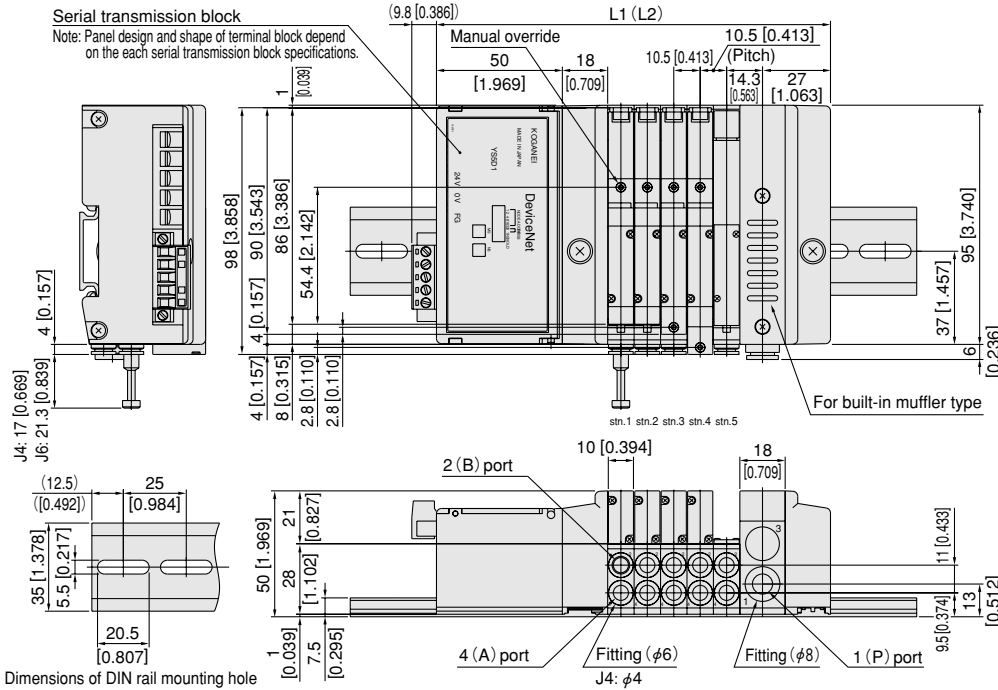

[Installation example]

- CS-JAM5SJ-MR-D1**
- stn.1 CS-JA10A1-J6-D4
- stn.2 CS-JA10A5-J6-D4
- stn.3 CS-JA10A6-J6-D4
- stn.4 CS-JA10A7-J6-D4
- stn.5 CS-JABPP-J6

Unit dimensions

Number of units	L1	DIN rail length	L2 ^{Note}	DIN rail length ^{Note}
2	125.0 [4.921]	175 [6.890]	143.0 [5.630]	200 [7.874]
3	135.5 [5.335]	200 [7.874]	153.5 [6.043]	200 [7.874]
4	146.0 [5.748]	200 [7.874]	164.0 [6.457]	225 [8.858]
5	156.5 [6.161]	225 [8.858]	174.5 [6.870]	225 [8.858]
6	167.0 [6.575]	225 [8.858]	185.0 [7.283]	250 [9.843]
7	177.5 [6.988]	225 [8.858]	195.5 [7.697]	250 [9.843]
8	188.0 [7.402]	250 [9.843]	206.0 [8.110]	275 [10.827]
9	198.5 [7.815]	250 [9.843]	216.5 [8.524]	275 [10.827]
10	209.0 [8.228]	275 [10.827]	227.0 [8.937]	275 [10.827]
11	219.5 [8.642]	275 [10.827]	237.5 [9.350]	300 [11.811]
12	230.0 [9.055]	275 [10.827]	248.0 [9.764]	300 [11.811]
13	240.5 [9.469]	300 [11.811]	258.5 [10.177]	325 [12.795]
14	251.0 [9.882]	300 [11.811]	269.0 [10.591]	325 [12.795]
15	261.5 [10.295]	325 [12.795]	279.5 [11.004]	325 [12.795]
16	272.0 [10.709]	325 [12.795]	290.0 [11.417]	350 [13.780]

Note : When using 2 piping blocks.