

Vacuum Pump Unit EVP03 Series



- External air supply is unnecessary due to a built-in pump
- Air blow function for workpiece release is available as standard feature
- RS485 communication is equipped as standard
- Wide variation of pads and robot adapters
- Can install directly to Koganei's Electric Auto Hand Changer without a robot adapter
- Can be mounted on a small robots due to reduced size and weight

Vacuum Pump Unit EVP03 Series

The EVP03 Series is a suction transport device that has integrated a pressure and vacuum pump, a pressure sensor, and a switching valve.

4 types of robot adapters and several vacuum pads are available, which allows you to select the most suitable combination for your robot and workpieces to be transferred.

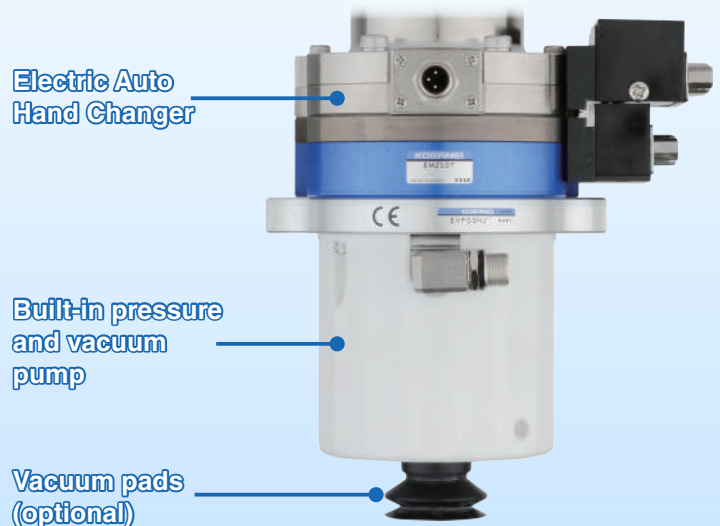

■ External air source and piping is unnecessary due to the built-in pump.

Contributes to carbon neutrality with airless operation!

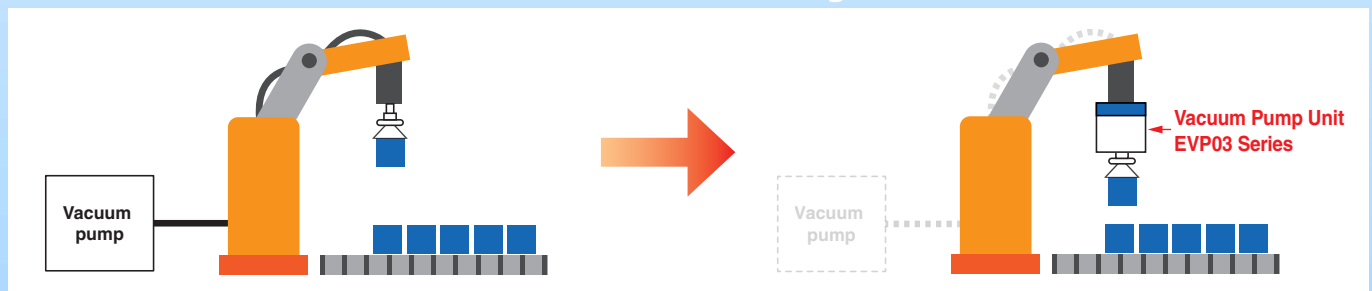

■ Equipped with an air blow function for workpiece release, which uses a built-in pressure and vacuum pump.

Shorten transfer operation time with reliable and speedy workpiece release!!

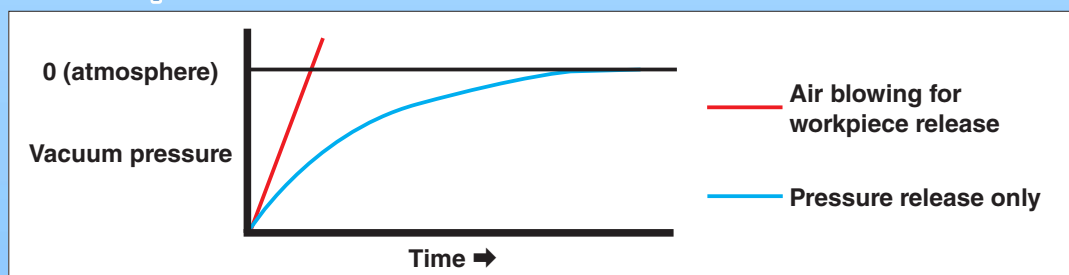

■ Possible to hold vacuum pressure while the workpiece is being sucked. The pump will stop while the vacuum pressure is being maintained, enabling energy saving.

■ Equipped with a control function that enables the workpiece to be sucked or released with an external signal only.

Also, RS485 communication is supported,
realizing IoT workpiece transfer!!

Simple lamp indication of the operation status

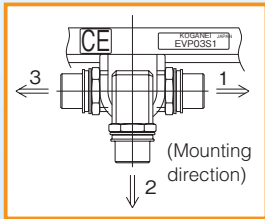

The connector direction can be selected according to the cable routing direction.

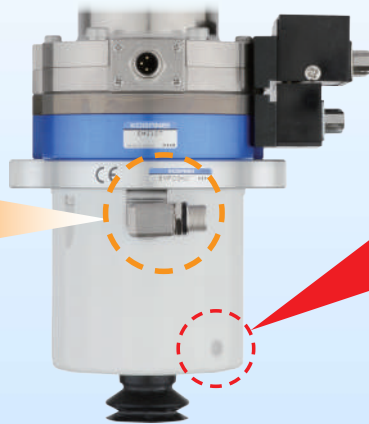

Wide variation of vacuum pads and robot adapters

For vacuum pads, the standard type and bellows type are available. Also, an extension joint with filter is available as an option.



Vacuum pads



Vacuum pads (Bellows type)



Vacuum pads + Extension joint with filter



Extension joint with filter

4 types of robot adapters available

- ISO standard flange 1 (pitch diameter: $\phi 25$ [0.984])
- ISO standard flange 2 (pitch diameter: $\phi 31.5$ [1.240])
- ISO standard flange 3 (pitch diameter: $\phi 40$ [1.575])
- ISO standard flange 4 (pitch diameter: $\phi 50$ [1.969])

* The electric hand changer type (EVP03MJ) is not provided with a robot adapter.
(The unit is assembled directly to the tool side of the electric auto hand changer.)
* For details on the ISO standards, refer to ISO 9409-1 and JIS B 8436.

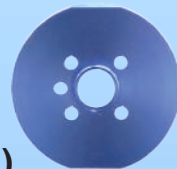

Flange 1

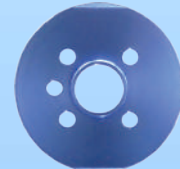

Flange 2

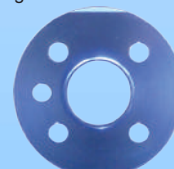

Flange 3

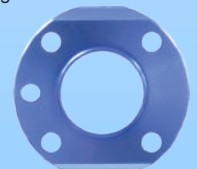

Flange 4

Can be mounted on a small robots due to reduced size and weight

(Examples of usage)

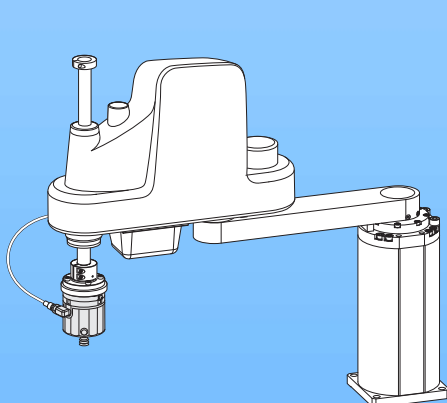

SCARA robot

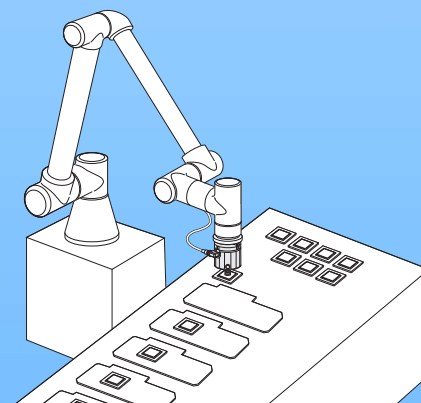

Collaborative robot

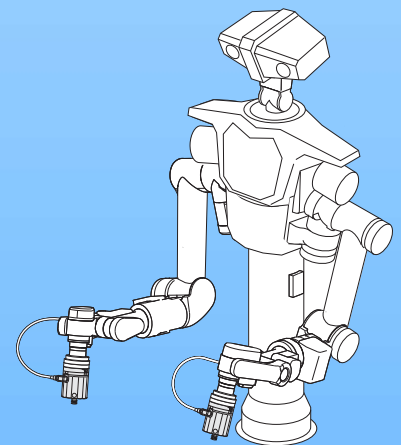





Double-arm robot

Before selecting and using an appropriate product, please read all the safety precautions carefully to ensure proper product use. The safety precautions described below are intended to help you use the product safely and correctly and to prevent injury to you or other people and damage to property.

Always adhere to ISO4414 (Pneumatic fluid power - General rules and safety requirements for systems and their components), JIS B 8370 (Pneumatic fluid power- General rules and safety requirements for systems and their components), JIS B 8433 (Robots and robotic devices- Safety requirements for industrial robots), and other safety regulations.

The directions are classified according to the degree of potential danger or damage as DANGER, WARNING, CAUTION, and ATTENTION.

 DANGER	Indicates situations that can be clearly predicted as dangerous. Death or serious injury may result if the situation is not avoided. It could also result in damage or destruction of assets.
 WARNING	Indicates situations that, while not immediately dangerous, could become dangerous. Death or serious injury may result if the situation is not avoided. It could also result in damage or destruction of assets.
 CAUTION	Indicates situations that, while not immediately dangerous, could become dangerous. Minor or semi-serious injury may result if the situation is not avoided. It could also result in damage or destruction of assets.
 ATTENTION	Indicates no risk of injury, but gives points that should be observed for proper use of the product.

- This product was designed and manufactured as a part for use in general industrial machinery.
- Before selecting or handling equipment, a system designer or other person with sufficient knowledge and experience should first read the "Safety Precautions", "Catalog", "Owner's Manual" and other documentation. Handling errors create dangerous situations.
- The customer is responsible for all verification and decisions concerning the compatibility of this product with the customer's system.
- After reading the "Owner's Manual", catalog, and other documentation, store them in a location where they are easily available for reference by users of this product.
- Whenever transferring or lending the product to another person, always attach the instruction manual, and other information to the product where they are easily visible in order to ensure that the new user can use the product safely and properly.
- The danger, warning and caution items listed in these safety precautions do not cover all possible contingencies. Read the catalog and instruction manual carefully, and always keep safety first.

 **DANGER**

- Do not use the product for the purposes listed below:
 1. Medical equipment related to maintenance or management of human life or health
 2. Machines or equipment designed for the purpose of moving or transporting people
 3. Critical safety components in mechanical devices
 This product has not been planned or designed for purposes that require high levels of safety. Using the product in any of the ways described above creates the risk of loss of human life.
- Do not use the product in locations with dangerous substances such as flammable or ignitable substances. This product is not explosion-proof. There is a risk of ignition and fire.
- When mounting the product, always make sure it is firmly supported and secured (including the workpiece). If the product tips over, drops, or malfunctions, there is a risk of personal injury.
- Users of pacemakers or other similar medical devices should maintain a distance of at least 1 m [3.280 ft] from the product. Getting too close to the product creates the risk of malfunction of a pacemaker due to the strong magnet built in the product.
- Never modify the product. Doing so can cause malfunctions and create the risk of personal injury, electric shock, fire, etc.
- Never inappropriately disassemble/assemble or repair the basic structure, performance, or functions of the product. Doing so may cause injury, electric shock, fire, etc.
- Do not splash water on the product. Splashing water on the product, washing the product, or using the product under water may cause abnormal operation leading to injury, electric shock, fire, etc.
- While the product is operating, avoid touching it with your hands or otherwise approaching too close. Also while the product is operating, do not attempt to adjust internal or attached mechanisms (such as attaching/detaching connectors for wires, adjusting pressure switches, disconnecting tubes or sealed plugs, or adjusting the installation position of the product). If the product drops or malfunctions, there is a risk of personal injury.

 **WARNING**

- Koganei products can be used under a variety of conditions. Therefore, the person responsible for system design must fully evaluate the products to determine compatibility with the system. The designer who determines the suitability of the system is responsible for guarantying the desired performance and safety of the system. Study and evaluate the latest catalogs, technical documents, and specifications sufficiently to configure a system that assures safety and reliability, such as by using fail-safes that anticipate possible device malfunctions.
- Do not use the product in excess of its specification range. Using the product outside of its specified range could result in product breakdowns, stop of functions, or damage. It could also drastically reduce the operating life.
- Do not touch terminals with the power on. Doing so creates the risk of electric shock and abnormal operation.
- Do not allow the product to be thrown into fire. Doing so creates the risk of the product exploding or the release of toxic gases.
- Do not sit, stand, or place objects on the product. Doing so creates the risk of injury due to tripping or the product tipping over or falling, resulting in product damage and abnormal, erratic, or runaway operation.
- Design equipment, as well as safety circuits, so that people are not injured and equipment is not damaged if there is an emergency stop, power outage, or other system abnormality that stops the machinery.
- If using the product in the locations listed below, implement adequate shielding measures. Failure to implement these measures may lead to erratic operation that could cause equipment damage or personal injury.
 1. Locations subject to large electric current or magnetic fields
 2. Locations subject to noise due to static electricity, etc.
 3. Locations with the possibility of exposure to radiation

- Before installing the product to the equipment, be sure to check that the mounting, wiring, and operation commands are correct. Using the product without checking them could result in injury or equipment damage by coming in contact with moving parts.
- Before supplying electricity to the product and before starting operation, always conduct a safety check of the area where the equipment is operating. Unintentional supply of electricity creates the risk of electric shock or injury due to contact with moving parts.
- Before performing any kind of wiring work, be sure to turn off the electric power. Failure to do so creates the risk of electric shock.
- Correctly apply the rated voltage to the product. Applying the wrong voltage will make it impossible to obtain the rated function, and create the risk of damage to and burnout of the product.
- Do not allow lead wires and other cords to become damaged. Allowing a cord to become damaged, bent excessively, pulled, rolled up, placed under heavy objects, or squeezed between two objects creates the risk of current leaks or defective continuity that can lead to fire, electric shock, or abnormal operation.
- If abnormal noise occurs or vibrations are excessive, immediately stop operations. Continued use in this condition may result in abnormal operation or runaway operation due to product damage or destruction.
- Do not connect or disconnect connectors while the power is turned on. Also, never apply unnecessary force to connectors. Doing so creates the risk of personal injury, device damage, and electric shock due to abnormal machine operation.
- Always check the catalog and other reference materials for correct product wiring and piping. Improper wiring or piping creates the risk of abnormal operation.
- If the product is not used for long periods (over 30 days), it is possible that the sliding parts may have become stuck leading to slow operation or sudden movements, possibly resulting in injury. Check for proper operation a minimum of once every 30 days.
- Do not use the main unit cable in locations near power lines through which large electric currents flow or that are subject to strong magnetic fields or surges. Doing so could result in unintended operation.
- The product may generate surge voltages or electromagnetic waves even while it is off, adversely affecting the operation of peripheral equipment. Use anti-surge solenoids and equip electrical circuits with protection against surges and electromagnetic waves.
- Do not use the product near the ocean, in direct sunlight, near mercury vapor lamps, or near equipment that generates ozone. Deterioration of rubber parts caused by ozone may reduce performance and functions, or stop functions. (except for ozone-resistant products)
- Do not use media other than the ones listed in the specification table. Using a medium not listed in the specification table could lead to a short-term stoppage of functions, sudden degradation in performance, or reduced operating life.
- When the product has been idle for over 48 hours or has been in storage, the sliding parts may have become stuck, leading to operating delays or sudden movements at initial operation. Before initial operation, always run a test to check that operations are normal.
- After completing wiring work, check to make sure that all connections are correct before turning on the power.

- Do not use the product in locations subject to direct sunlight (ultraviolet radiation); in locations subjected to high temperature or humidity; in locations where dust, salt, or iron particles are present; or in locations with media and/or an ambient atmosphere that includes organic solvents, phosphate ester type hydraulic oil, sulfur dioxide gas, chlorine gas, acids, etc. Doing so could lead to stoppage of functions within a short period, a sudden degradation in performance, or reduced operating life. For information about materials, see materials of major parts.
- Be sure to completely cut off the power before doing any work, such as maintenance inspections, repairs, or replacing parts, on the product.

CAUTION

- When mounting the product, leave room for adequate working space around it. Failure to do so will make it more difficult to conduct daily inspections or maintenance, which could eventually lead to system shutdown or damage to the product.
- Do not use the product in environments that contain corrosive gases, combustible gases, flammable liquids, etc. It could lead to a decrease in strength due to rust, or to a risk of the motor igniting or exploding.
- Do not scratch, dent, or deform the product by climbing on it, using it as a step, or placing objects on top of it. Doing so could result in operations stopping or performance falling due to the product being damaged or broken.
- The product does not have a filter or filtration device in it. When using the product, install an extension joint with filter (EVPF-M5) as necessary.
- When doing installation or adjustment work, clearly display work-in-progress signs so that the electric power supply is not turned on unintentionally. Unintentional supply of electricity creates the risk of injury due to sudden operation or electric shock.
- Do not bring any magnetic media or magnetic data within 1 m [3.280 ft] of the product while the power is on. Doing so creates the risk of damage to data on the magnetic medium due to magnetism.
- The achievable vacuum pressure may not be reached if the product is used at a high altitude or due to atmospheric pressure variation. In this case, adjust the [External output ON pressure] setting to an achievable vacuum pressure by using the service software, etc.
- Do not continue suction (vacuum) or forced vacuum break (positive pressure) operation for 10 minutes or more. Also, after continuous operation for a certain time, do not start another operation until that time has elapsed. If the product temperature exceeds 57°C [135°F], a high temperature alarm is issued, and the product cannot be used until the product has cooled down sufficiently. The alarm is reset when the power is turned OFF.
- Be careful that positive pressure is not supplied from the suction port of the product. There is a risk of damage to the vacuum gauge or vacuum pump.
- Do not subject the ends of the main unit cable to excessive force.
- Do not fasten the main unit cable connectors so they are subject to bending moment.
- This product is not completely air-leak-free. Designs should take into consideration the capacity and retention time required for vacuum retention, etc.

ATTENTION

- When considering using the product for applications that demand extreme safety, such as aviation facilities, combustion equipment, leisure equipment, safety devices, or in other ways predicted to greatly affect assets or human lives, or in situations or environments not described in the Catalog or Owner's Manual, etc., take sufficient safety precautions, such as by allowing ample rating and performance margins for the application and by implementing adequate safety measures, such as fail-safes. Also, be sure to consult us about such applications.
- Isolate the operating components of machinery, such as with protective covers, so there is no direct contact with people.
- Do not configure controls so that workpieces fall if there is a power outage.
Configure measures to prevent workpieces from falling in case the equipment has a power outage or emergency stop.
- Use the product at an ambient temperature between 5 to 40°C [41 to 104°F]. When incorporating the product into your equipment, make sure that the ambient temperature is between 5 to 40°C [41 to 104°F].
- Wear protective gloves, safety glasses, safety shoes, and other protective clothing as necessary to be safe when handling the product.
- Always conduct daily inspections and confirm that all requisite system functions are satisfied to prevent accidents from happening.
- When the product can no longer be used or is no longer necessary, dispose of it appropriately as industrial waste.
- Pneumatic equipment can exhibit degraded performance and functions over its operating life. Always conduct daily inspections on pneumatic equipment and confirm that all requisite system functions are satisfied to prevent accidents from happening.
- For inquiries about the product, consult your nearest Koganei sales office or the Overseas Department. The addresses and telephone numbers are shown on the back cover of this catalog.

Other precautions

- Always observe the following items.
 1. When using this product in a pneumatic system, use only genuine Koganei parts or compatible parts (recommended parts).
Use only genuine Koganei parts or compatible parts (recommended parts) to do maintenance or repairs.
Use only specified procedures and methods.
 2. Never inappropriately disassemble or assemble the product in relation to its basic construction, performance, or functions.

Koganei bears no responsibility if these safety precautions are not fully observed.

Warranty and disclaimer
1. Warranty period

The warranty period of Koganei products is one year from the date of delivery.

* Some products have a two-year warranty period. For details, contact the nearest Koganei sales office or Overseas Department.

2. Warranty scope and disclaimer

- (1) If a failure attributable to Koganei is found in a product purchased from Koganei or an authorized retailer/dealer during the warranty period, Koganei will repair or replace it free of charge. For some products, a service life, such as the number of operations, may be specified in their warranty periods. For details, contact the nearest Koganei sales office or the Overseas Department.
- (2) The Koganei product warranty covers that product alone. Consequently, Koganei is not responsible for any incidental damage (including costs incurred for the repair and replacement of the product) attributable to any failure of the Koganei product, decrease in function, or decrease in performance.
- (3) Koganei is not responsible for any losses or for any damages to other machinery caused by breakdown, loss of function, or loss of performance of Koganei products.
- (4) Koganei is not responsible for any losses due to use or storage of the product in a way that is outside of the product specifications prescribed in Koganei catalogs and instruction manuals, and/or due to actions that violate the mounting, installation, adjustment, maintenance or other safety precautions.
- (5) Koganei is not responsible for any losses caused by breakdown of the product due to factors outside the responsibility of Koganei, including but not limited to fire, natural disaster, the actions of third parties, and intentional actions or errors by the purchaser.



General precautions

Mounting

1. Follow the instructions below to securely mount the product on a robot, etc. Tighten the bolts to the tightening torques shown to the right.

1. Loosen brackets ① and remove robot adapter ④.
2. Attach knock pin ③ to the robot.
3. Fasten robot adapter ④ with bolts ②.
4. Fasten the product with brackets ①.

At this time, tighten the brackets to a tightening torque of 0.49 N·m [4.337 in·lbf].

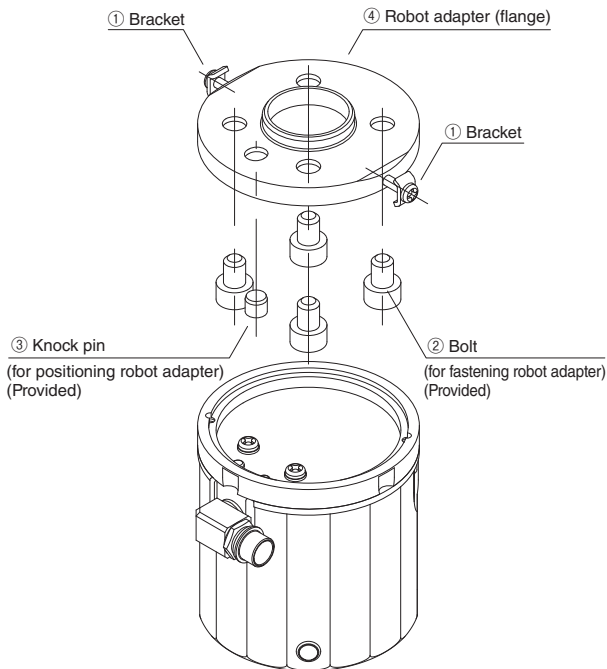

* EVP03MJ (for Electric Auto Hand Changer) is not provided with a robot adapter. Install EVP03MJ directly to the tool side of the electric auto hand changer by using the attached bolts and pins.

● EVP03MJ

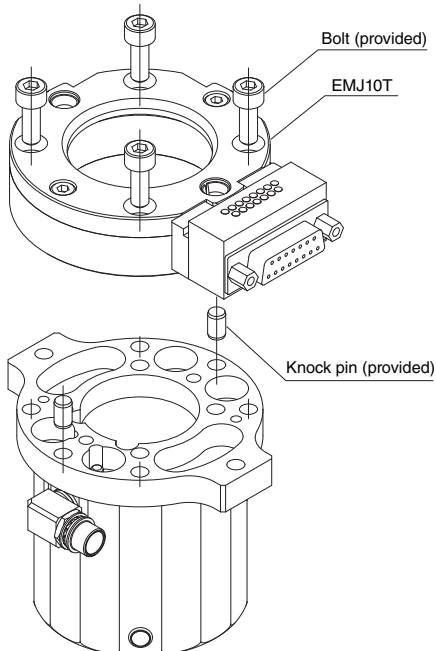

● Tightening torque for bolts

Bolt size	Tightening torque N·m [in·lbf]
M4	1.5 [13.277]
M5	3.0 [26.553]
M6	5.2 [46.025]

2. Do not subject the product directly to strong impact or vibration.
3. Avoid use in locations and environments like those described below, which can result in damage to internal valves or other parts.
 - Locations directly exposed to dripping water or oil
 - Environments in which condensation forms on the product
 - Locations directly exposed to cuttings or dust
 - Locations exposed to salt, corrosive gasses, or electroconductive powders
4. Before installing piping to the product, thoroughly flush the inside of the pipes (with compressed air). Cuttings, sealing tape, or rust produced while doing piping work that gets inside the product could cause air leaks or reduced performance.
5. Periodically replace or clean the extension joint with filter (Order code: **EVPF-M5**), which is an additional part.
6. Do not excessively twist or apply strong tensile force to the cables and connectors. Also, always carry the product by its body, and do not apply excessive force to the cables.

Handling Instructions and Precautions (Vacuum Pump Unit)



General precautions

Wiring

1. Dedicated cables are provided with the product. The terminal positions of the cables, wiring colors, and items are shown below.

● Cable terminal positions

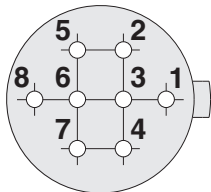

No.	Name	Sheath color	Description
1	24V	Red	Power supply
2	0V	Black	Power supply
3	SW	Brown	Output signal Threshold reached
4	VAC	Blue	Input signal 1
5	BLW	Green	Input signal 2
6	0V	Yellow	RS485 communication 0V
7	A	White	RS485 communication A
8	B	Orange	RS485 communication B

2. After finishing wiring, check that the connections are correct.
 3. Do not allow a current of 75 mA or more to flow at output signal No. 3. An alarm is issued by the overcurrent protection circuit. The alarm is reset when the power is turned OFF.

* To prevent the inclusion of noise or surges, use as short a cable as possible. (Recommended cable length: Less than 30 m [98.400 ft]) For protection against lightning surges, take measures on your equipment side.

Direction of cable

For the cable direction, you can select the longitudinal direction (one type) or lateral direction (three types). This cannot be changed after purchase. Be sure to select this when you order.

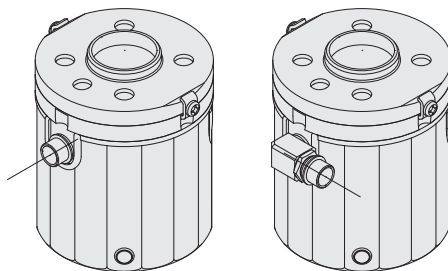

Blank: Pull out longitudinally 1: Pull out rightward

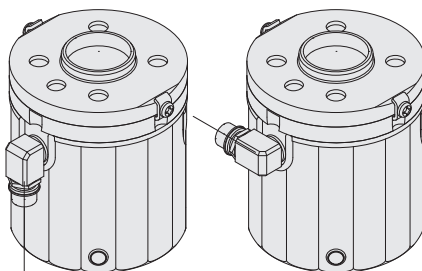

2: Pull out downward 3: Pull out leftward



Piping

Piping

1. Connect the vacuum pads and other parts to the suction port.
2. Use tubing with an interior diameter that cannot be constricted. A small diameter means the flow and pressure become insufficient, which reduces the achievable vacuum and lengthens the time to achieve it, resulting in reduced performance.
3. The larger internal volume the tube has, the longer it takes to reach the achievable vacuum.
4. When using a quick joint, tighten it to a torque of 1.0 to 1.6 N·m [8.851 to 14.162 in·lbf].

Troubleshooting

Symptom	Major causes	Remedies
Power does not turn on	Power was not be turned on Improper wiring	Check that the power is turned on. Check that the wiring is correct.
Red lamp is lit	Internal temperature is high (Threshold is exceeded)	Turn off the power and wait until the internal temperature drops.
Red lamp blinks	Overcurrent of external output	Turn off the power and check the wiring and loads.
Green lamp blinks	Input signal OFF not detected	Turn off input signal 1 and input signal 2.
No vacuum is generated after vacuum signal is turned on	Input signal 1 is not turned on Improper wiring	Check that input signal 1 is turned on. Check that the wiring is correct.
No positive pressure is generated after positive pressure signal is turned on	Input signal 2 is not turned on Improper wiring	Check that input signal 2 is turned on. Check that the wiring is correct.
Vacuum pressure does not reach external output ON pressure	High altitude Unstable atmospheric pressure	Adjust the external output ON pressure to an achievable vacuum pressure.
No external signal is input after vacuum pressure has reached external output ON pressure	Improperly set external output ON pressure Improper wiring	Check that the set value is correct. Check that the wiring is correct.
External signal is output before vacuum pressure reaches external output ON pressure	Improperly set external output ON pressure	Check that the set value is correct.

Other precautions

1. This product assumes that the workpiece is sucked with vacuum pads. Avoid subjecting the product directly to a large force, such as striking the workpiece against the vacuum pad.
2. The set conditions are written and stored in the built-in flash memory. Note that the flash memory reaches the end of life when it is overwritten 10,000 times.

Handling Instructions and Precautions (Vacuum Pump Unit)



Vacuum pads

Storage

1. The vacuum pads (including the rubber of the pads) use various types of rubber. Rubber degenerates when exposed to direct sunlight, oil, water, or ozone. Before use, store them indoors and keep them sealed in their polyethylene bags.
2. Set the storage temperature to room temperature.
3. As a guideline, the storage period is 2 years from manufacture.

Product

The outside circumference of the rubber of the pads may be uneven, due to the rubber mold, but this does not affect performance.

Mounting and replacing pad rubber

The method to change the pad rubber varies, either "Screw-on type" or "Insert type", depending on the size of the pads.

<Screw-on type>

The compatible pad sizes are KP10 to 20, PA10 to 20, PB10 to 20, and TB10 to 25. To mount the pads, gradually screw in the mounting screw, then after the pad rubber and the mounting screw come together, tighten the mounting screw another half turn (180 degrees).

<Insert type>

The compatible pad sizes are KP2 to 8, PA2 to 8, PB2 to 8, TB6 to 8, and TC5 to 19. To mount the pads, first mount the mounting screws (tightening torque of 1.47 N·m [13.011 in·lbf]), then attach the pads.

General precautions

1. If the pads are being used to press a workpiece, do not apply extreme force. Doing so causes the pads to deform, crack, and wear more quickly, so set the position within the range of pad deformation.
2. If the workpiece is swiveled, the screws of the extension joint with filter and the mounting screws of the pad rubber may loosen and come off, so design a system with leeway for this. Also, suctioning a workpiece with a skewed center of gravity takes particular care, so check that carefully.
3. Because the vacuum pads are made of rubber, increasing the number of suction/release operations on the workpiece causes wear, or sticking to the workpiece or sticking to the pads. If harmful scratches, wear, or cracks occur on the pads, promptly replace them.
4. The maximum payload of the extension joint with filter is 3 kg [6.615 lb].

Tightening torque

When installing the extension joint with filter, tighten it to the tightening torque shown below.

Model	Screw size	Tightening torque N·m [in·lbf]
EVPF-M5	M5x0.8	1.6 [14.162]

Supportable suction angle

If the suction surface is on a workpiece with a slanted surface, then you can use a bellows pad that can suction at an angle of about 5°, but this is just a reference value because it varies depending on the workpiece and usage conditions.

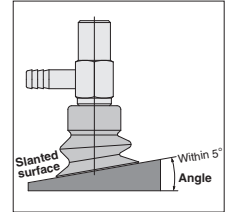

Vacuum Pump Unit

EVP03 Series



Specifications

● Basic specifications of main unit

Standard model		EVP03S1	EVP03S2	EVP03S3	EVP03S4	EVP03MJ
General	Item					
	Maximum payload	kg [lb]	3 [6.615]			
	Motor		Brushed motor			
	Power supply voltage	VDC	24±10%			
	Power consumption	W	5			
	Medium		Air			
	Achieved vacuum pressure	kPa [inHg]	-60 [-17.724] ^{Note 1}			
	Maximum suction flow rate	L/min (ANR) [ft ³ /min (SCFM)]	1 [0.035]			
	Operating temperature range	°C [°F]	5 to 40 [41 to 104]			
	Allowable bending moment	N·m [in·lbf]	0.9 [7.966]			
	Allowable torsional moment	N·m [in·lbf]	1.6 [14.162]			
	Withstand voltage		1 minute at 500 VAC			
	Insulation resistance		At 500 VDC megger, then 100 MΩ or higher			
	Shock resistance	m/s ² [G]	392.3 [40]			
	Surface material		Housing: PA2000 Top panel and flange mechanical interface: Aluminum			
Mass (w/o option, not including accessories)	kg [oz]	195 [6.88]		200 [7.05]	210 [7.41]	
Standards		CE				
Noise	dB	67				
IP protection grade		IP20				
Piping	Quantity	1				
	Piping size	M5 female thread depth 5				
Wiring	Cable specifications	Heat-resistant, oil-resistant, low-friction insulated plastic sheathed cable				
	No. of conductors	8 conductors				
	Wiring size	Conductor: AWG26 (0.15 mm ² [0.0002 in ²]) Outside diameter φ0.51 mm [0.020 in.] Insulator: Outside diameter φ0.91 mm [0.036 in.]				
	Connector pin assignment	See Table 1 on page ⑩.				
Minimum bending radius	mm [in.]	40 [1.575]				
External output	Number of outputs	1				
	Output type	NPN open collector				
	Applied voltage	V Max	30			
	Applied current	mA Max	50			
	Internal voltage drop	V Max	0.3 (at 5 mA)			
	Output mode		Hysteresis mode			
External input	Functions	External output ON, external output OFF				
	Lamp indication	See Table 2 on page ⑩.				
	Number of inputs	2				
Communication	Functions	See Table 3 on page ⑩.				
	Communication standard	RS485				
	Communication speed	bps	115200			
	Communication protocol	Modbus-RTU				
	Address setting	Not required				
Daisy-chain connection	Not supported					
Functions	External output ON/OFF pressure setting, vacuum retention value setting, achieved vacuum value setting, zero compensation of pressure					

Note 1: At standard atmospheric pressure (1013 hPa [0.029 inHg])

Connector pin assignment

[Table 1]

No.	Name	Sheath color	Description
1	24V	Red	Power supply
2	0V	Black	Power supply
3	SW	Brown	Output signal Threshold reached
4	VAC	Blue	Input signal 1
5	BLW	Green	Input signal 2
6	0V	Yellow	RS485 communication 0V
7	A	White	RS485 communication A
8	B	Orange	RS485 communication B

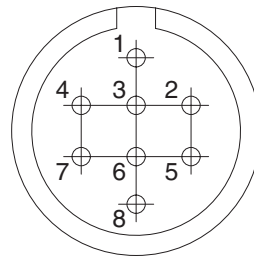

Lamp indication

[Table 2]

Status	Color	Indication	Description
Power OFF	-	Not lit	
Input signal OFF not detected	Green	Blinking	When external signal has been selected in mode selection
Standby	Green	Lit	
Suctioning (output signal OFF)	Light blue	Lit	
Suctioning (output signal ON)	Dark blue	Lit	
Forced vacuum break (positive pressure)	Purple	Lit	
Pressure released	Yellow	Lit	
High temperature alarm	Red	Lit	
Output overcurrent alarm	Red	Blinking	Forced output OFF for output protection

External input function

[Table 3]

Command	Input signal 1	Input signal 2
Standby	OFF	OFF
Suction (vacuum)	ON	OFF
Forced vacuum break (positive pressure)	OFF	ON
Pressure released	ON	ON

Factory default settings of pressure

Command	Factory default setting	Setting range ^{Note 1}
External output ON pressure	-50 kPa [-14.770 inHg]	-40 to -60 kPa [-11.816 to -17.724 inHg]
External output OFF pressure	-5 kPa [-1.477 inHg]	-5 to -10 kPa [-1.477 to -2.954 inHg]
Vacuum retention value ^{Note 2}	7 kPa [2.068 inHg]	7 to 10 kPa [2.068 to 2.954 inHg]
Achieved vacuum value ^{Note 3}	0 kPa [0 inHg]	0 to 5 kPa [0 to 1.477 inHg]

Notes 1: To change the settings, an optionally available USB-RS485 converter (EVPH1 or EVPH1-N) and dedicated setup software are required. The dedicate setup software is available from Koganei's website.

2: When the pressure drops by the vacuum retention value from the external output ON pressure, the vacuum pump is restarted.
Example: When the external output ON pressure and vacuum retention value are set to -50 kPa [-14.770 inHg] and 7 kPa [2.068 inHg], respectively

When the pressure value drops to -43 kPa [-12.702 inHg], the vacuum pump is restarted.

3: This setting is for compensation in case of vacuum overshoot in relation to the external output ON pressure due to the external output ON pressure, secondary-side volume, and other conditions.

Air pressure circuit diagram

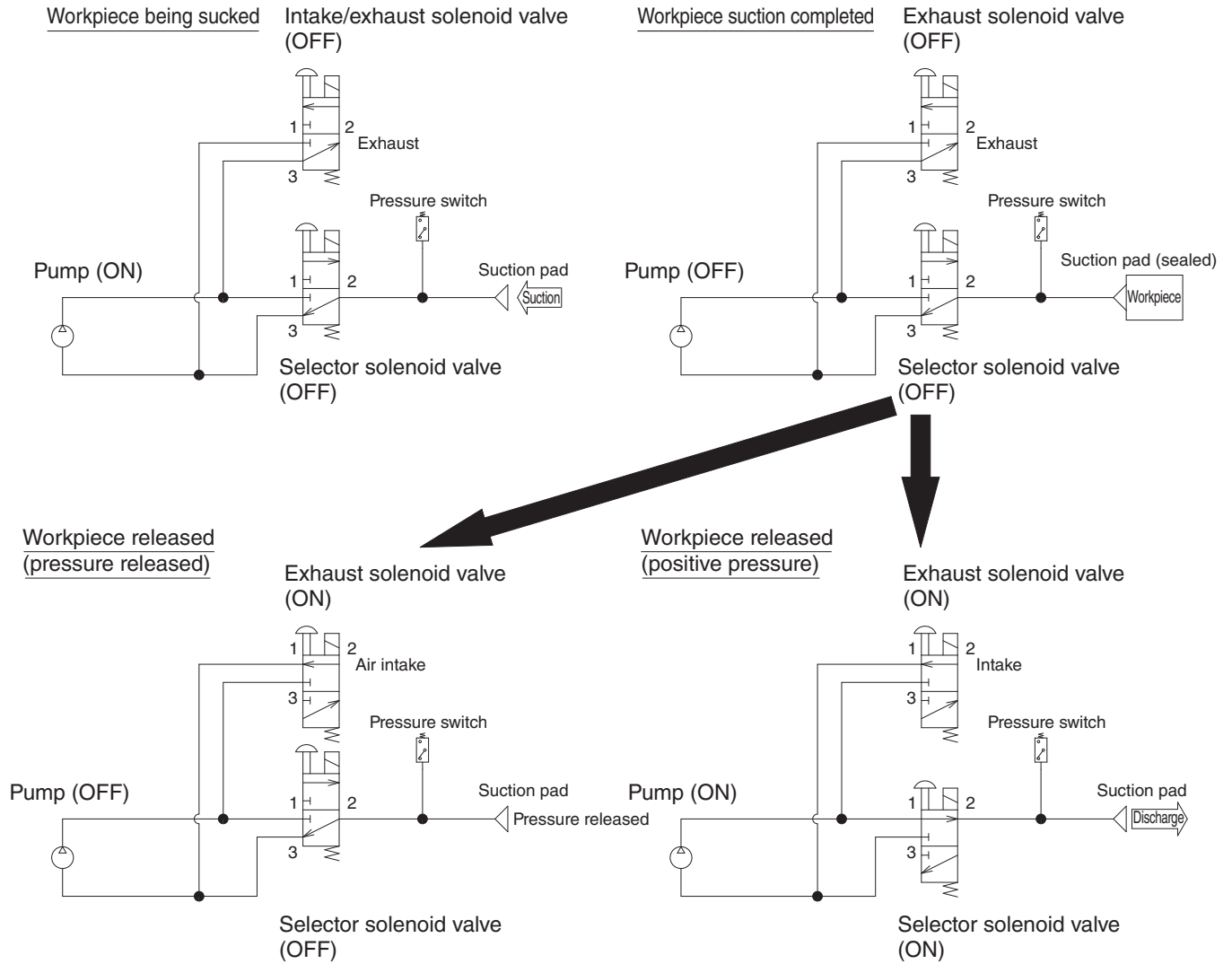

Order codes

● Vacuum pump unit model

EVP 03 - - - -

Pad material^{Note 3}
N : NBR (KP, TB, and TC)
 Conductive NBR (PA)
 Halogen-coated NBR (PB)
S : Silicone (KP, TB, and TC)
 Conductive silicone (PA)
U : Urethane (KP)
 Conductive urethane (PA)
F : Fluorine (KP)
LF : Fluorine for suction marks (KP)

Pad diameter^{Note 3}
 See Table 4.

Pad type^{Note 2}
Blank : No vacuum pads
KP : Standard type
PA : Conductive type
PB : Halogen-coated type
TB : Bellows type 1.5 folds
TC : Bellows type 2.5 folds

Mesh filter^{Note 2}
Blank : None
F : Extension joint with filter
 * 50-mesh filter
 (filter mesh size 330 μm)

Power/control cable length^{Note 2}
Blank : No cable
015L : 150 mm [5.906 in.]
025L : 250 mm [9.843 in.]
3L : 3,000 mm [118.1 in.]
5L : 5,000 mm [196.9 in.]

Connector direction^{Note 4}
Blank : Straight
1 : Pull out in direction 1
2 : Pull out in direction 2
3 : Pull out in direction 3

Mounting flange shape^{Note 1}
S1 : For mounting ISO standard flange 1, pitch diameter 25 [0.984]
S2 : For mounting ISO standard flange 2, pitch diameter 31.5 [1.240]
S3 : For mounting ISO standard flange 3, pitch diameter 40 [1.575]
S4 : For mounting ISO standard flange 4, pitch diameter 50 [1.969]
MJ : For mounting auto hand changers EMJ3T and EMJ10T^{Note 5}

Notes 1: Mounting flange: For S1, S2, S3, and S4, hex socket bolts (4 pcs.) and knock pin (1 pc.) are provided. For MJ, hex socket bolts (4 pcs.) and two different types of knock pins (2 pcs. per type) are provided.
 2: Attached at the time of shipment if selected
 3: Unselectable if "No pads"
 4: See the dimensional drawing below for the connector direction.
 5: Cannot be installed directly to the following types of EMJ3T and EMJ10T:
 EMJ3T-R1,-R2,-R3
 EMJ10T-R1,-R3

Vacuum Pump Unit
 EVP03 Series

[Table 4: Combination of pad types and pad diameters]

mm [in.]

Type	Pad diameter											
	2 [0.079]	3.5 [0.138]	5 [0.197]	6 [0.236]	7 [0.276]	8 [0.315]	9 [0.354]	10 [0.394]	15 [0.591]	19 [0.748]	20 [0.787]	25 [0.984]
KP	○	○	-	○	-	○	-	○	○	-	○	-
PA	○	○	-	○	-	○	-	○	○	-	○	-
PB	○	○	-	○	-	○	-	○	○	-	○	-
TB	-	-	-	○	-	○	-	○	○	-	○	○
TC	-	-	○	-	○	-	○	-	○	○	-	-

Additional parts

● Cable

EVPKBA -

Cable length

- 015L : 150 mm [5.906 in.]
- 025L : 250 mm [9.843 in.]
- 3L : 3,000 mm [118.1 in.]
- 5L : 5,000 mm [196.9 in.]

● Communication cable (USB-RS485 converter)

EVPH1 -

Supplied cable

- Blank : USB (mini-B) male ↔ USB (A) male 900 mm [35.433 in.]
- N : No supplied cable

● Extension joint with filter

50-mesh filter (filter mesh size 330 µm)

EVPF - M5

● Connecting fitting set

IBZR8Z-KN



2 pcs. per set

● Vacuum pads + Mounting screws set

KPZ -

Pad type

- KP : Standard type
- PA : Conductive type
- PB : Halogen-coated type
- TB : Bellows type 1.5 folds
- TC : Bellows type 2.5 folds

Pad diameter
See Table 5.

Pad material

- N : NBR (KP, TB, and TC)
Conductive NBR (PA)
Halogen-coated NBR (PB)
- S : Silicone (KP, TB, and TC)
Conductive silicone (PA)
- U : Urethane (KP)
Conductive urethane (PA)
- F : Fluorine (KP)
- LF : Fluorine for suction marks (KP)

● Vacuum pad model (w/o mounting screws)

KP - -

Pad type

- Blank : Standard type
- A : Conductive type
- B : Halogen-coated type
- TB : Bellows type 1.5 folds
- TC : Bellows type 2.5 folds

Pad diameter
See Table 5.

Pad material

- N : NBR (KP, KPTB, and KPTC)
Conductive NBR (KPA)
Halogen-coated NBR (KPB)
- S : Silicone (KP, KPTB, and KPTC)
Conductive silicone (KPA)
- U : Urethane (KP)
Conductive urethane (KPA)
- F : Fluorine (KP)
- LF : Fluorine for suction marks (KP)

[Table 5: Combination of pad types and pad diameters]

mm [in.]

Type	Pad diameter											
	2 [0.079]	3.5 [0.138]	5 [0.197]	6 [0.236]	7 [0.276]	8 [0.315]	9 [0.354]	10 [0.394]	15 [0.591]	19 [0.748]	20 [0.787]	25 [0.984]
KP	○	○	-	○	-	○	-	○	○	-	○	-
PA (KPA)	○	○	-	○	-	○	-	○	○	-	○	-
PB (KPB)	○	○	-	○	-	○	-	○	○	-	○	-
TB (KPTB)	-	-	-	○	-	○	-	○	○	-	○	○
TC (KPTC)	-	-	○	-	○	-	○	-	○	○	-	-

Remarks: The types in parentheses indicate vacuum pads without mounting screws.

Theoretical lifting force

N [lbf]

Pad diameter mm [in.]	Pad area cm ² [in ²]	Vacuum kPa [inHg]				
		-60 [-17.724]	-55 [-16.247]	-50 [-14.770]	-45 [-13.293]	-40 [-11.816]
2 [0.079]	0.049 [0.00008]	0.294 [0.066]	0.270 [0.061]	0.245 [0.055]	0.221 [0.050]	0.196 [0.044]
3.5 [0.138]	0.096 [0.00014]	0.576 [0.129]	0.528 [0.119]	0.480 [0.108]	0.432 [0.097]	0.384 [0.086]
5 [0.197]	0.196 [0.00030]	1.176 [0.264]	1.078 [0.242]	0.980 [0.220]	0.882 [0.198]	0.784 [0.176]
6 [0.236]	0.283 [0.00044]	1.698 [0.382]	1.557 [0.350]	1.415 [0.318]	1.274 [0.286]	1.132 [0.254]
7 [0.276]	0.385 [0.00060]	2.310 [0.519]	2.118 [0.476]	1.925 [0.433]	1.733 [0.390]	1.540 [0.346]
8 [0.315]	0.503 [0.00078]	3.018 [0.678]	2.767 [0.622]	2.515 [0.565]	2.264 [0.509]	2.012 [0.452]
9 [0.354]	0.636 [0.00099]	3.816 [0.858]	3.498 [0.786]	3.180 [0.715]	2.862 [0.643]	2.544 [0.572]
10 [0.394]	0.785 [0.00122]	4.710 [1.059]	4.318 [0.971]	3.925 [0.882]	3.533 [0.794]	3.140 [0.706]
15 [0.591]	1.767 [0.00274]	10.602 [2.383]	9.719 [2.185]	8.835 [1.986]	7.952 [1.788]	7.068 [1.589]
19 [0.748]	2.835 [0.00439]	17.010 [3.824]	15.593 [3.505]	14.175 [3.187]	12.758 [2.868]	11.340 [2.549]
20 [0.787]	3.142 [0.00487]	18.852 [4.238]	17.281 [3.885]	15.710 [3.532]	14.139 [3.178]	12.568 [2.825]
25 [0.984]	4.909 [0.00761]	29.454 [6.621]	27.000 [6.070]	24.545 [5.518]	22.091 [4.966]	19.636 [4.414]

Remarks: Set the safety factor of each pad type in consideration of the following magnifications:

- Standard type, conductive type, and halogen-coated type
- Bellows type: (1.5 folds/2.5 folds)

Note: The values in this table are calculated values.

- Horizontal lifting: ×2 or more
- Vertical lifting: ×4 or more
- Horizontal lifting: ×10 or more
- Vertical lifting: Not permitted

Material and compatibility of pad rubber

For details on the material and compatibility (e.g., mechanical and electrical properties) of pad rubber, see the vacuum pad catalogs at Koganei's website.
For use, give sufficient consideration to these conditions.

EVP03S1 (For mounting ISO standard flange 1, pitch diameter 25 [0.984])

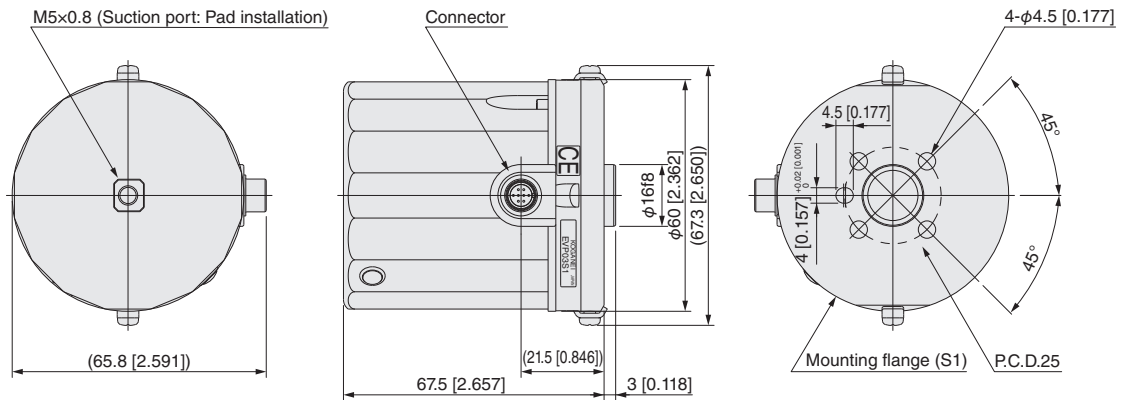

* Hex socket bolts M4x6 (4 pcs.) and Knock pin Type B 4x6 (1 pc.) are provided.

Note) Do not change the connector direction. Doing so may result in damage.

Connector pin assignment

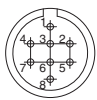

Pin location

No.	Item
1	Power supply (24 V)
2	Power supply (0 V)
3	Output signal (threshold reached)
4	Input signal 1
5	Input signal 2
6	RS485 (0 V)
7	RS485 (A)
8	RS485 (B)

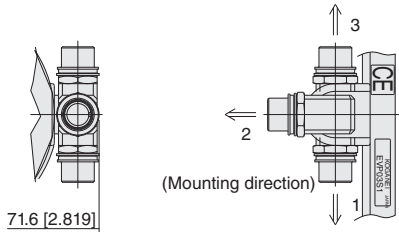

Connector direction: When code 1 to 3 is selected

EVP03S2 (For mounting ISO standard flange 2, pitch diameter 31.5 [1.240])

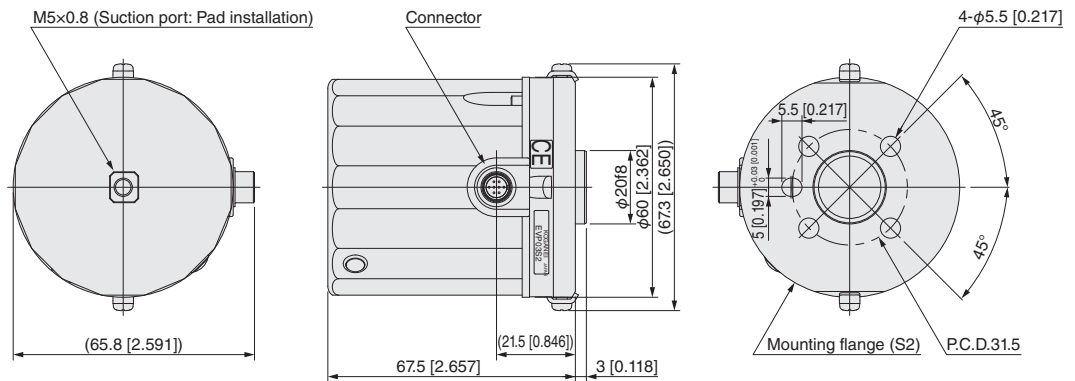

* Hex socket bolts M5x6 (4 pcs.) and Knock pin Type B 5x6 (1 pc.) are provided.

Note) Do not change the connector direction. Doing so may result in damage.

Connector pin assignment



Pin location

No.	Item
1	Power supply (24 V)
2	Power supply (0 V)
3	Output signal (threshold reached)
4	Input signal 1
5	Input signal 2
6	RS485 (0 V)
7	RS485 (A)
8	RS485 (B)

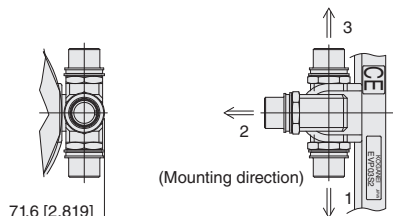

Connector direction: When code 1 to 3 is selected

EVP03S3 (For mounting ISO standard flange 3, pitch diameter 40 [1.575])

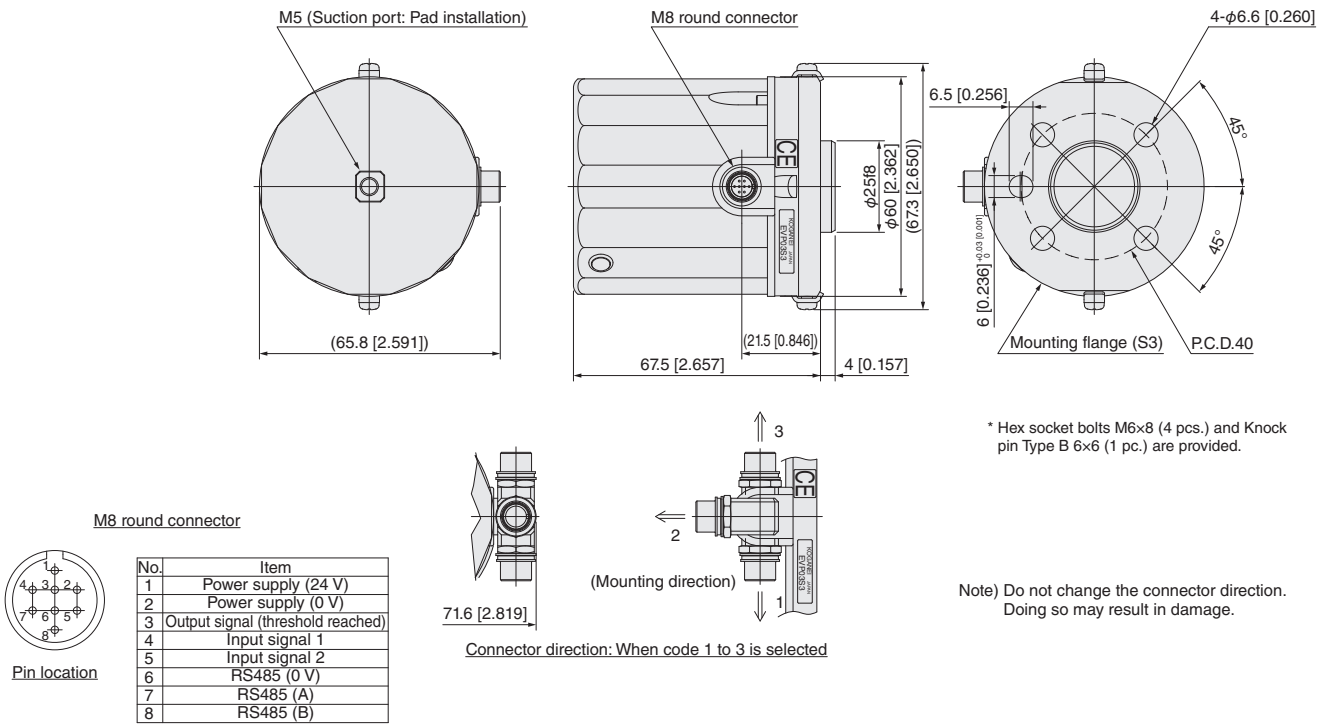

EVP03S4 (For mounting ISO standard flange 4, pitch diameter 50 [1.969])

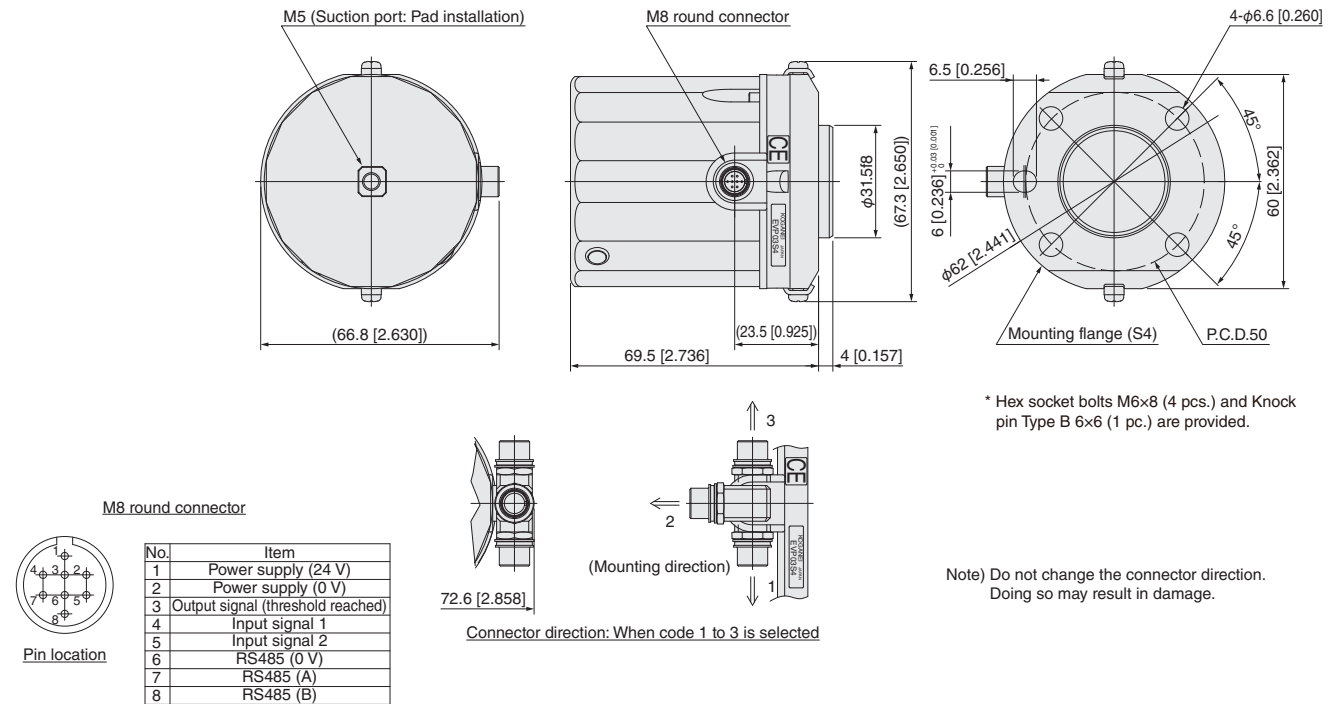

EVP03MJ (For mounting Electric Auto Hand Changer EMJ3T/ EMJ10T)

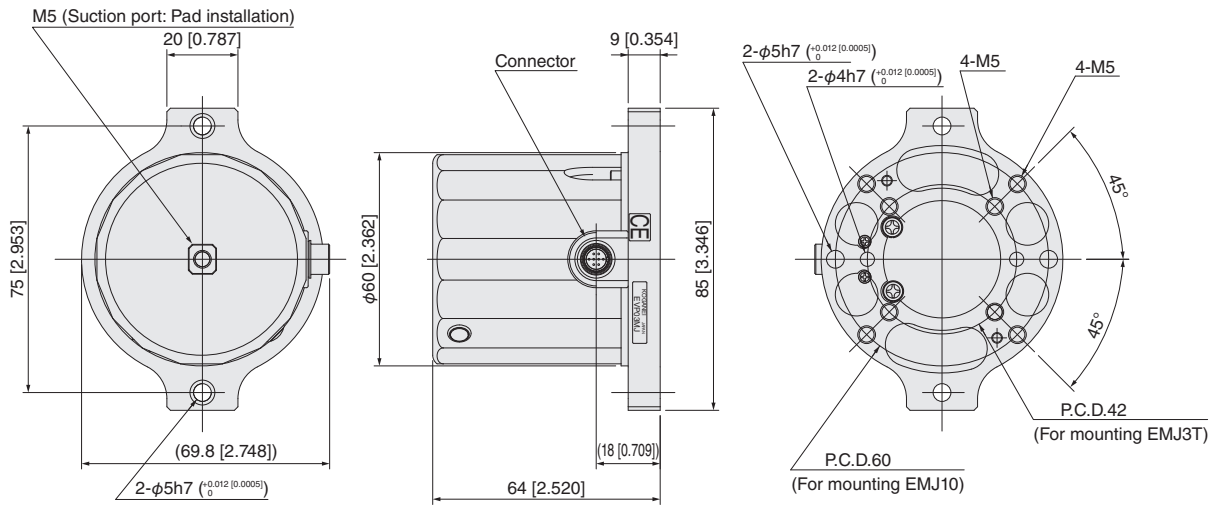

Connector pin assignment

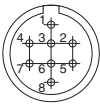

Pin location

No.	Item
1	Power supply (24 V)
2	Power supply (0 V)
3	Output signal (threshold reached)
4	Input signal 1
5	Input signal 2
6	RS485 (0 V)
7	RS485 (A)
8	RS485 (B)

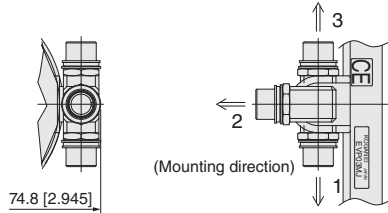

Connector direction: When code 1 to 3 is selected

* Hex socket bolts M5×14 (4 pcs.), Knock pins Type B 4×8 (2 pcs.) (for EMJ3T), and knock pins Type B 5×8 (2 pcs.) (for EMJ10T) are provided.

Note) Do not change the connector direction. Doing so may result in damage.

Additional parts dimensions (mm [in.])

● Cable

EVPKBA -

Cable length
015L : 150 mm [5.906 in.]
025L : 250 mm [9.843 in.]
3L : 3,000 mm [118.1 in.]
5L : 5,000 mm [196.9 in.]

Main unit-side connector

Connector PIN No.	Item	Wire color
1	Power supply (24 V)	Red
2	Power supply (0 V)	Black
3	Output signal (threshold reached)	Brown
4	Input signal 1	Blue
5	Input signal 2	Green
6	RS485 (0 V)	Yellow
7	RS485 (A)	White
8	RS485 (B)	Orange

Cable shield /

Cable wiring chart

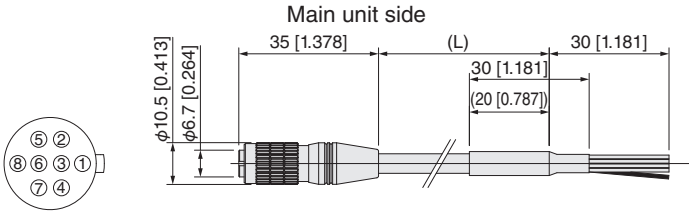

Pin location

● Communication cable (USB-RS485 converter)

EVPH1 -

Supplied cable
Blank : USB (mini-B) male → USB (A) male 900 mm [35.433 in.]
N : None

For power and control

Vacuum pump unit side

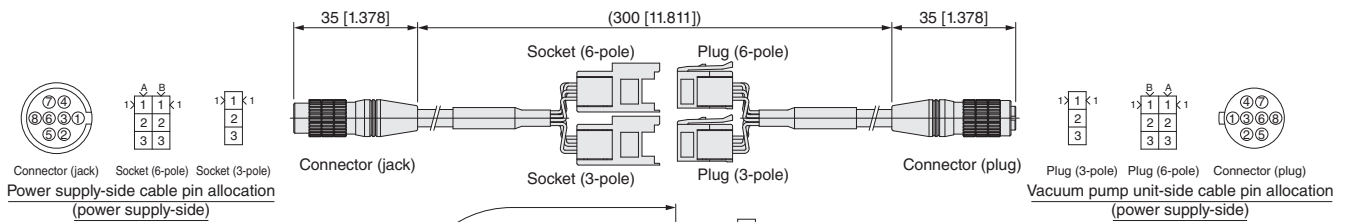

Power supply-side cable wiring chart

Connector PIN No.	Item	Wire color	Socket (6-pole) PIN No.	Socket (3-pole) PIN No.
1	Power supply (24 V)	Red	A-1	
2	Power supply (0 V)	Black	B-1	
3	Output signal (threshold reached)	Brown	A-2	
4	Input signal 1	Blue	B-2	
5	Input signal 2	Green	A-3	
6	RS485 (0 V)	Yellow		3
7	RS485 (A)	White		1
8	RS485 (B)	Orange		2

Converter cable wiring chart

Socket (3-pole) PIN No.	Item	Wire color
1	RS485 (A)	Brown
2	RS485 (B)	Blue
3	RS485 (0 V)	Black

Vacuum pump unit-side cable wiring chart

Connector PIN No.	Item	Wire color	Plug (6-pole) PIN No.	Plug (3-pole) PIN No.
1	Power supply (24 V)	Red	A-1	
2	Power supply (0 V)	Black	B-1	
3	Output signal (threshold reached)	Brown	A-2	
4	Input signal 1	Blue	B-2	
5	Input signal 2	Green	A-3	
6	RS485 (0 V)	Yellow		3
7	RS485 (A)	White		1
8	RS485 (B)	Orange		2

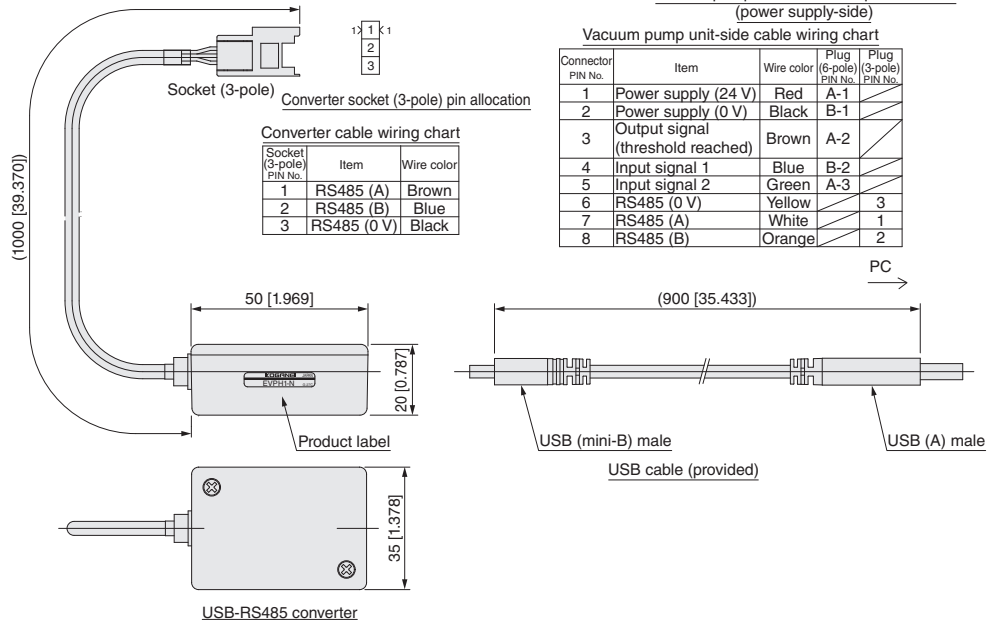

● Extension joint with filter

50-mesh filter (filter mesh size 330 μm)

EVPF - M5

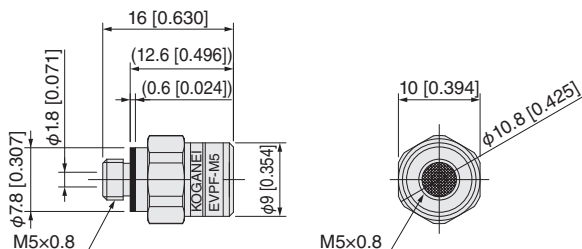

Pad rubber + Mounting screw dimensions (mm [in.]) (Caution: Pad rubber and mounting screws are a set product)

(KPZ)-KP □

(KPZ)-PA □

(KPZ)-PB □

● 2-3.5

Mounting screw for 2
Mounting screw for 3.5

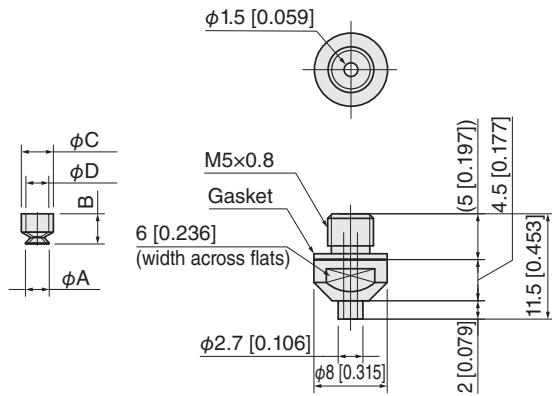

Model number for just pad	Item	A	B	C	D
KP-2-□		2.6	3.3	3.5	2.5
KPA-2-□		[0.102]	[0.130]	[0.138]	[0.098]
KPA-2-N					
KP-3.5-□		3.9	3.5	3.5	2.5
KPA-3.5-□		[0.154]	[0.138]	[0.138]	[0.098]
KPB-3.5-N					

● 6-8

Mounting screw for 6
Mounting screw for 8

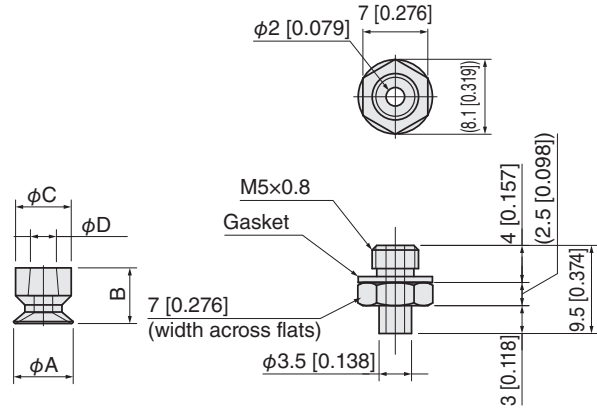

Model number for just pad	Item	A	B	C	D
KP-6-□		6.4	6	6	2.8
KPB-6-□		[0.252]	[0.236]	[0.236]	[0.110]
KPB-6-N					
KP-8-□		8.3	5.5	6	2.8
KPA-8-□		[0.327]	[0.217]	[0.236]	[0.110]
KPB-8-N					

● 10

Mounting screw for 10

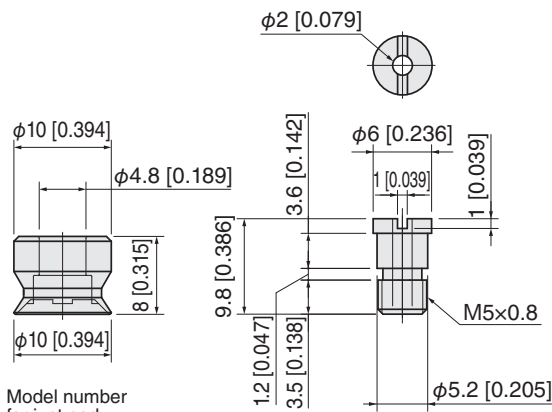

Model number for just pad
KP-10-□
KPA-10-□
KPB-10-N

● 15-20

Mounting screw for 15
Mounting screw for 20

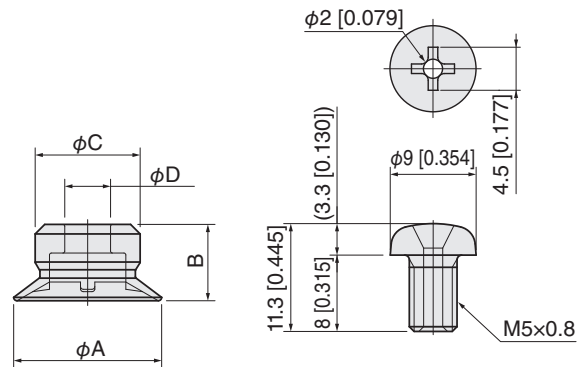

Model number for just pad	Item	A	B	C	D
KP-15-□		15.5	8	11	4.8
KPA-15-□		[0.610]	[0.315]	[0.433]	[0.189]
KPB-15-N					
KP-20-□		20.2	10	14	4.8
KPA-20-□		[0.795]	[0.394]	[0.551]	[0.189]
KPB-20-N					

Pad rubber + Mounting screw dimensions (mm [in.]) (Caution: Pad rubber and mounting screws are a set product)

(KPZ-)TB□

● 6

Mounting screw for 6

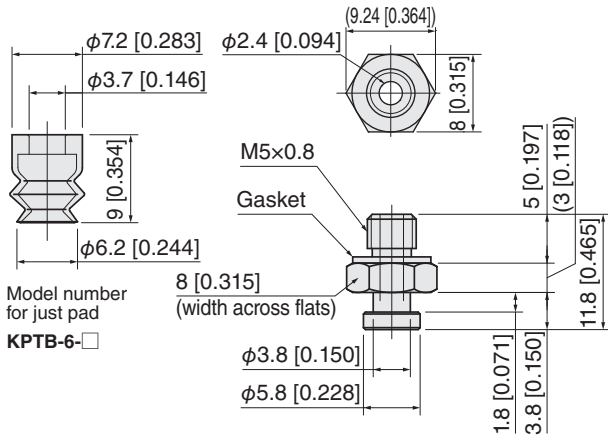

● 8

Mounting screw for 8

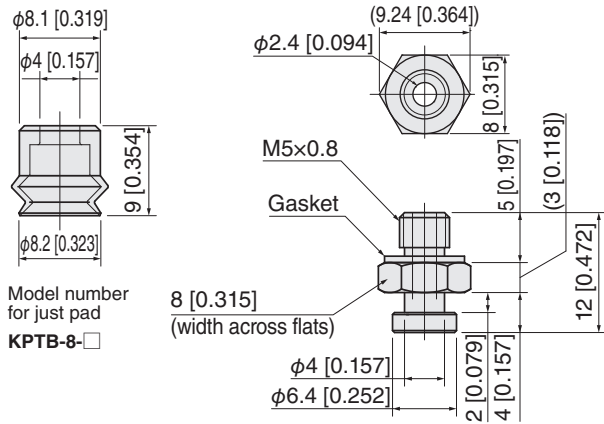

● 10-15

Mounting screw for 10
Mounting screw for 15

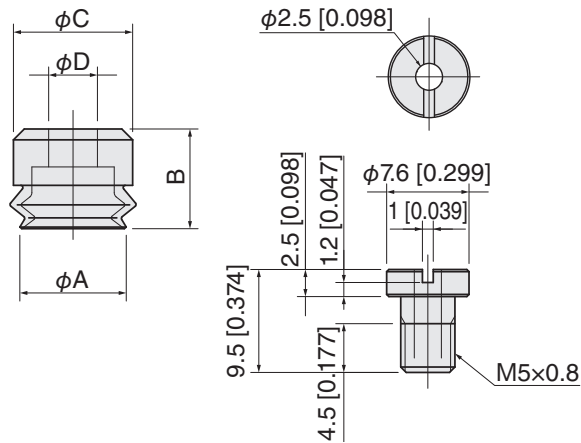

● 20-25

Mounting screw for 20
Mounting screw for 25

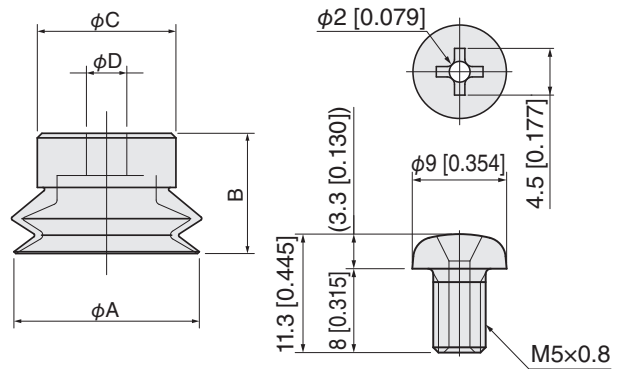

Model number for just pad \ Item	A	B	C	D
KPTB-10-□	9.8 [0.386]	9.2 [0.362]	11 [0.433]	4.5 [0.177]
KPTB-15-□	15.5 [0.610]	11 [0.433]	12 [0.472]	4.5 [0.177]

Model number for just pad \ Item	A	B	C	D
KPTB-20-□	20.2 [0.795]	13.1 [0.516]	15.1 [0.594]	4.4 [0.173]
KPTB-25-□	25.8 [1.016]	15.5 [0.610]	17.5 [0.689]	4.6 [0.181]

Pad rubber + Mounting screw dimensions (mm [in.]) (Caution: Pad rubber and mounting screws are a set product)

(KPZ)-TC□

● 5-7

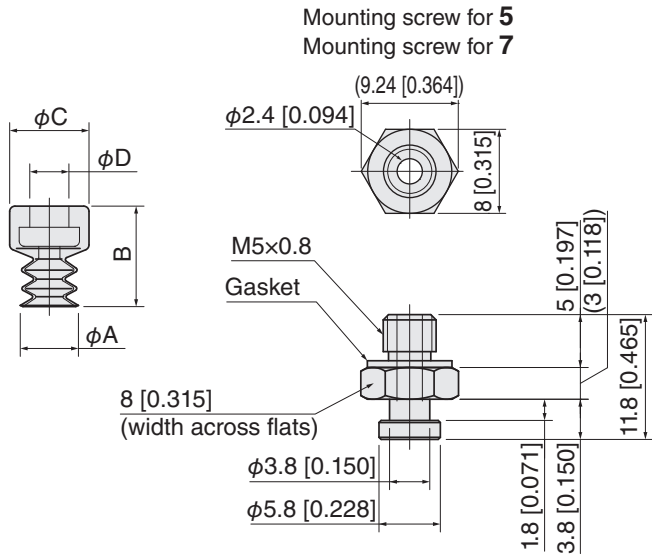

● 9

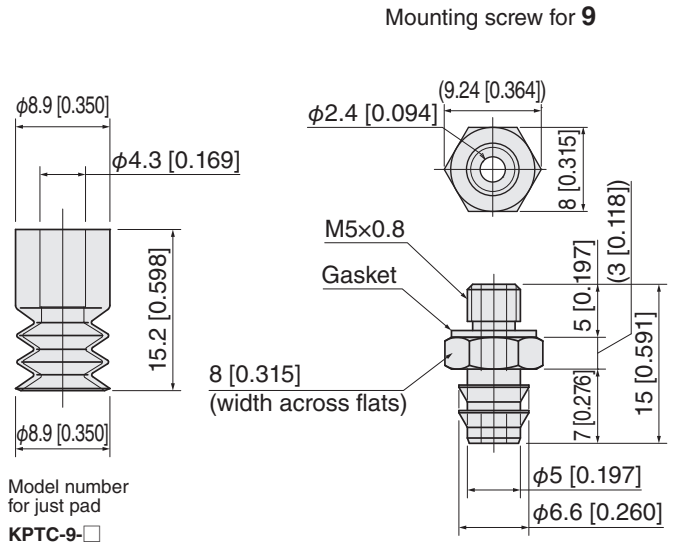

Model number for just pad \ Item	A	B	C	D
KPTC-5-□	5.5 [0.217]	9.5 [0.374]	7.5 [0.295]	3.7 [0.146]
KPTC-7-□	7.2 [0.283]	9.9 [0.390]	7.5 [0.295]	3.8 [0.150]

● 15-19

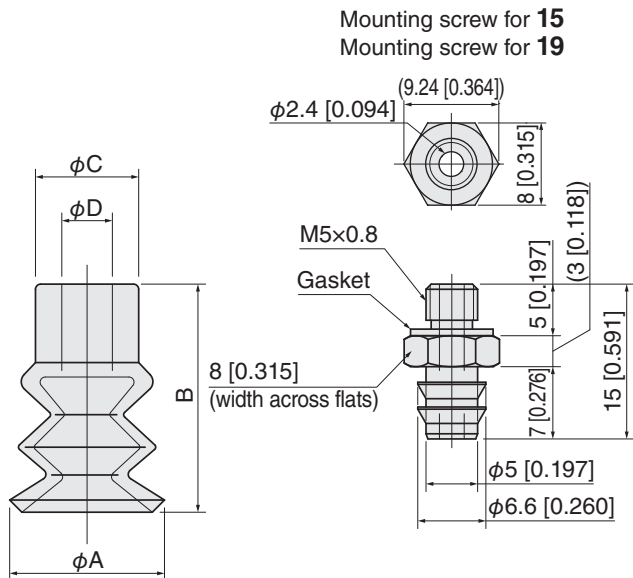

Model number for just pad \ Item	A	B	C	D
KPTC-15-□	15 [0.591]	22.1 [0.870]	10 [0.394]	4.9 [0.193]
KPTC-19-□	19.2 [0.756]	23.2 [0.913]	11.4 [0.449]	4.6 [0.181]

MEMO

Limited Warranty

KOGANEI CORP. warrants its products to be free from defects in material and workmanship subject to the following provisions.

Warranty Period The warranty period is 180 days from the date of delivery.

Koganei Responsibility If a defect in material or workmanship is found during the warranty period, KOGANEI CORP. will replace any part proved defective under normal use free of charge and will provide the service necessary to replace such a part.

Limitations

- This warranty is in lieu of all other warranties, expressed or implied, and is limited to the original cost of the product and shall not include any transportation fee, the cost of installation or any liability for direct, indirect or consequential damage or delay resulting from the defects.

- KOGANEI CORP. shall in no way be liable or responsible for injuries or damage to persons or property arising out of the use or operation of the manufacturer's product.

- This warranty shall be void if the engineered safety devices are removed, made inoperative or not periodically checked for proper functioning.

- Any operation beyond the rated capacity, any improper use or application, or any improper installation of the product, or any substitution upon it with parts not furnished or approved by KOGANEI CORP., shall void this warranty.

- This warranty covers only such items supplied by KOGANEI CORP. The products of other manufacturers are covered only by such warranties made by those original manufacturers, even though such items may have been included as the components.

The specifications are subject to change without notice.

URL <http://www.koganei.co.jp>

E-mail: overseas@koganei.co.jp



KOGANEI CORPORATION

OVERSEAS DEPARTMENT

3-11-28, Midori-cho, Koganei City, Tokyo 184-8533, Japan
Tel: (+81)42-383-7271 Fax: (+81)42-383-7276

KOGANEI INTERNATIONAL AMERICA, INC.

48860 Milmont Drive, suite 108C, Fremont, California 94538
Tel: 1-510-744-1626 Fax: 1-510-744-1676

SHANGHAI KOGANEI INTERNATIONAL TRADING CORPORATION

RM2601-2602, Tongda Venture Building No.1, Lane 600, Tianshan Road,
Shanghai, China (200051)
Tel: 86-21-6145-7313 Fax: 86-21-6145-7323

TAIWAN KOGANEI TRADING CO., LTD

Rm. 2, 16F., No88, Sec. 2, Zhongxiao E. Rd., Zhongzheng Dist., Taipei City 100,
Taiwan(ROC)
Tel: 886-2-2393-2717 Fax: 886-2-2393-2719

KOGANEI KOREA CO., LTD

A-3001, Heungdeok IT Valley Bldg., Heungkeok 1-ro, 13, Giheung-gu, Yongin-si, Gyeonggi-do,
446-908, KOREA
Tel: 82-31-246-0414 Fax: 82-31-246-0415

KOGANEI (THAILAND) CO., LTD

555, Rasa Tower 1, 11th Fl., Unit 1107 and 1108, Phaholyothin Road, Chatuchak,
Chatuchak, Bangkok 10900
Tel: +66 (0) 2513-1228-31 Fax: +66 (0) 2513-1232

KOGANEI AUTOMATION (MALAYSIA) SDN, BHD.

Suite 29-2, Level 29, Menara 1MK, No.1, Jalan Kiara, Mont Kiara
50480, Kuala Lumpur, Malaysia
Tel: 60-12-537-7086

KOGANEI ASIA PTE. LTD.

69 Ubi Road 1, #05-18 Oxley Bizhub Singapore 408731
Tel: 65-6293-4512 Fax: 65-6293-4513