











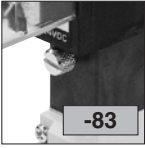
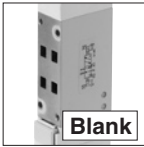



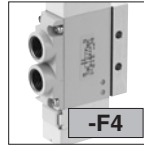













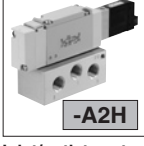

F18 Series Single Valve Unit Order Codes

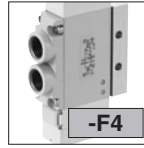
Valve size	Manual override	Valve outlet type	Wiring specification			
<p>F18 18 mm [0.709 in.] width</p>	<p>Manual override button</p>  <p>Blank</p> <p>No protrusion with DIN connector</p> <p>Manual override lever^{Note1}</p>  <p>-R</p> <p>Protruding locking type^{Note5}</p>  <p>-83</p>	<p>Without inlet/outlet block</p>  <p>Blank</p> <p>With outlet port dual use fitting block</p>  <p>-FJ</p> <p>Outlet port fitting $\phi 8, \phi 10$</p> <p>With outlet port female thread block</p>  <p>-F3</p> <p>Inlet port Rc1/4 Outlet port fitting $\phi 8, \phi 10$</p> <p>With outlet port single use fitting block</p>  <p>-FJ5</p> <p>Outlet port fitting $\phi 8$</p> <p>With outlet port female thread block</p>  <p>-F4</p> <p>Inlet port Rc1/4 Outlet port Rc1/4</p> <p>With outlet port female thread block</p>  <p>-F4H</p> <p>Inlet port NPT1/4 Outlet port NPT1/4</p> <p>With outlet port single use fitting block</p>  <p>-FJ6</p> <p>Outlet port fitting $\phi 10$</p> <p>With outlet port female thread block</p>  <p>-FM</p> <p>Outlet port Rc1/4</p> <p>With outlet port female thread block</p>  <p>-FMH</p> <p>Outlet port NPT1/4</p> <p>With outlet port single use fitting block</p>  <p>-F5</p> <p>Inlet port Rc1/4 Outlet port fitting $\phi 8$</p> <p>With outlet port female thread block</p>  <p>-F6</p> <p>Inlet port Rc1/4 Outlet port fitting $\phi 10$</p>	<p>L type plug connector Without connector</p>  <p>Blank</p> <p>S type plug connector Without connector</p>  <p>-PN</p> <p>S type plug connector Lead wire 300 mm^{**}</p>  <p>-PS</p> <p>L type plug connector Lead wire 300 mm^{**}</p>  <p>-PL</p> <p>S type plug connector Lead wire 3000 mm^{**}</p>  <p>-PS3</p> <p>L type plug connector Lead wire 3000 mm^{**}</p>  <p>-PL3</p> <p>DIN connector type with indicator^{Note6}</p>  <p>-39L</p> <p>DIN connector type without connector^{Note6}</p>  <p>-39N</p>			
<p>Valve specification</p> <p>T0 : 2-position, for single solenoid only T1 : 2-position single solenoid specification (for both single and double solenoid use) T2 : 2-position double solenoid specification (for both single and double solenoid use) T3 : 3-position closed center T4 : 3-position exhaust center^{Note4} T5 : 3-position pressure center^{Note4}</p>	<p>Operation type</p> <p>Blank</p> <p>Internal pilot type</p> <p>G</p> <p>External pilot type^{Note} (for positive pressure)</p> <p>V</p> <p>External pilot type^{Note} (for vacuum)^{**} ^{**} This is a vacuum valve.</p> <p>Note: When using as a single unit, select -A2 (A type with sub-base) for the valve outlet type. Without a sub-base, piping for the external pilot is not possible.</p>	<p>With A type sub-base</p>  <p>-A2</p> <p>Inlet/outlet port Rc1/4</p> <p>With A type sub-base</p>  <p>-A2H</p> <p>Inlet/outlet port NPT1/4</p>	<p>With outlet port dual use fitting block</p>  <p>-F3</p> <p>Inlet port Rc1/4 Outlet port fitting $\phi 8, \phi 10$</p> <p>With outlet port female thread block</p>  <p>-F4</p> <p>Inlet port Rc1/4 Outlet port Rc1/4</p> <p>With outlet port single use fitting block</p>  <p>-FJ6</p> <p>Outlet port fitting $\phi 10$</p> <p>With outlet port female thread block</p>  <p>-FM</p> <p>Outlet port Rc1/4</p> <p>With outlet port female thread block</p>  <p>-FMH</p> <p>Outlet port NPT1/4</p> <p>With outlet port single use fitting block</p>  <p>-F5</p> <p>Inlet port Rc1/4 Outlet port fitting $\phi 8$</p> <p>With outlet port female thread block</p>  <p>-F6</p> <p>Inlet port Rc1/4 Outlet port fitting $\phi 10$</p>			
Valve size	Valve specification	Operation type	Manual override	Valve outlet type	Wiring specification	Voltage
F18	T0 T1 T2 T3 T4 ^{Note4} T5 ^{Note4}	Blank G V	Blank -R ^{Note1} -83 ^{Note5}	Blank ^{Note2} -A1 ^{Note2} -A2 -A2H -FJ ^{Note2, 4} -FJ5 ^{Note2, 4} -FJ6 ^{Note2, 4} -FM ^{Note2, 4} -FMH ^{Note2, 4} -F3 ^{Note3} -F4 ^{Note3} -F4H ^{Note3} -F5 ^{Note3} -F6 ^{Note3}	Blank -PN -PS -PL -PS3 -PL3 -39L ^{Note6} -39N ^{Note6}	DC24V DC12V AC100V ^{Note7} AC120V AC240V ^{Note5}

Notes: 1. When the valve specification is T1 or T2, the manual override lever is placed only on the A side. This is not available with -39□.
2. Two manifold mounting screws are included.
3. "With inlet port female thread block" is compatible with the internal pilot type valve only.
4. Not available in the vacuum valves.
5. Only for wiring specification -39□.

6. Not available for valve specification T1. In addition, the valve is used only as a double solenoid for T2.
7. Not available with DIN connectors.

Remark: Negative common specifications are also available as made to order products (add -129W to the end of order code). For details, consult us.

F18 Series Single Valve Unit Additional Parts Order Codes

● For internal pilot

F18 Z -

Parts content

- 21** : Mounting bracket (mounting bracket, 2 mounting screws)
- 25** : Sub-base Rc1/4 (sub-base body, gasket, exhaust valve)^{Note1}
- 25H** : Sub-base NPT1/4 (sub-base body, gasket, exhaust valve)^{Note1}
- P** : Plate (plate, gasket, 2 mounting screws)
- J** : Dual use fitting block (fitting block, gasket, 2 mounting screws)
- J5** : Single use fitting block ϕ 8 (fitting block, gasket, 2 mounting screws)
- J6** : Single use fitting block ϕ 10 (fitting block, gasket, 2 mounting screws)
- M** : Female thread block Rc1/4 (female thread block, gasket, 2 mounting screws)
- MH** : Female thread block NPT1/4 (female thread block, gasket, 2 mounting screws)
- MP** : P port female thread block Rc1/4 (P port female thread block, gasket)^{Note1}
- MPH** : P port female thread block NPT1/4 (P port female thread block, gasket)^{Note1}
- GS1** : Gasket (gasket, exhaust valve)^{Note2}

Notes: 1. Valve mounting screws are not included.
 2. Caution should be exercised as this gasket is different from the **GS2** gasket for the split-type manifolds.

● For external pilot

F18 Z -

Parts content

- P** : Plate (plate, gasket, 2 mounting screws)
- J** : Dual use fitting block (fitting block, gasket, 2 mounting screws)
- J5** : Single use fitting block ϕ 8 (fitting block, gasket, 2 mounting screws)
- J6** : Single use fitting block ϕ 10 (fitting block, gasket, 2 mounting screws)
- M** : Female thread block Rc1/4 (female thread block, gasket, 2 mounting screws)
- MH** : Female thread block NPT1/4 (female thread block, gasket, 2 mounting screws)
- GS1** : Gasket (gasket, exhaust valve)^{Note}

Note: Caution should be exercised as this gasket is different from the **GS2** gasket for the split type manifolds.

Sub-base for external pilot

- F18 ZG - 25 (Sub-base Rc1/4)**
- F18 ZG - 25H (Sub-base NPT1/4)**

Connector-related order codes

FZ -

Valve specification
 For T1, T2, T3, T4, T5

Connector specification

- CP** : Connector, lead wire length 300 mm [11.8 in.] (black, red, white, for total of 3 lead wires)
- CP3** : Connector, lead wire length 3000 mm [118 in.] (black, red, white, for total of 3 lead wires)
- CLN** : Connector without lead wire (1 short bar and 3 contacts included)
- CC1.5** : Cabtyre cable length 1500 mm [59 in.]^{*}
- CC3** : Cabtyre cable length 3000 mm [118 in.]^{*}

^{*}For details, see p. 19.

FZ0 -

Valve specification
 For T0

Connector specification

- CP** : Connector, lead wire length 300 mm [11.8 in.] (black, red, for total of 2 lead wires)
- CP3** : Connector, lead wire length 3000 mm [118 in.] (black, red, for total of 2 lead wires)
- CLN** : Connector without lead wire (1 short bar, 2 contacts included)

ORDER CODES

F18 Series Monoblock Manifold A Type (Base Piping Type) Order Codes

Valve size

F18M

18 mm [0.709 in.] width

Manifold outlet specification

With dual use fitting blocks (base piping type)

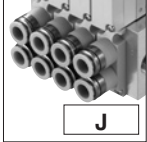

Outlet port fitting
φ 8, φ 10

With selectable fittings (base piping type)



Outlet port should be selected in accordance with the manifold fitting specification.

With female thread blocks (base piping type)

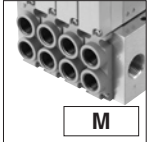

Outlet port female thread
Rc1/4

Valve specification

- T0: 2-position, for single solenoid only
- T1: 2-position, single solenoid specification
- T2: 2-position, double solenoid specification
- T3: 3-position, closed center
- T4: 3-position, exhaust center^{Note6}
- T5: 3-position, pressure center^{Note6}

Pilot specification

Blank

Internal pilot manifold

G

External pilot manifold

Operation type

Blank

Internal pilot type^{Note4}

G

External pilot type^{Note5}
(for positive pressure)

V

External pilot type^{Note5}
(for vacuum)^{*}
^{*} This is a vacuum valve.
Note: Cannot be mounted together with a positive pressure valve.

Manual override

Manual override button



No protrusion with DIN connector

Manual override lever^{Note2}



Protruding locking type^{Note7}

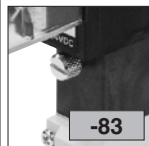

Valve outlet type

With plate^{Note3}
(base piping type)

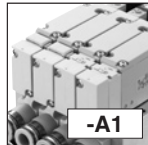

Wiring specification

L type plug connector
Without connector



S type plug connector
Without connector



S type plug connector
Lead wire 300 mm^{*}



L type plug connector
Lead wire 300 mm^{*}



S type plug connector
Lead wire 3000 mm^{*}



L type plug connector
Lead wire 3000 mm^{*}



Pre-wired positive common terminal
S type plug connector
Lead wire 300 mm^{*}

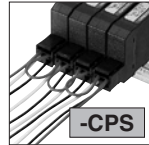

Pre-wired positive common terminal
L type plug connector
Lead wire 300 mm^{*}

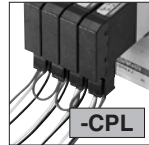

Pre-wired positive common terminal
S type plug connector
Lead wire 3000 mm^{*}

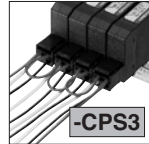

Pre-wired positive common terminal
L type plug connector
Lead wire 3000 mm^{*}

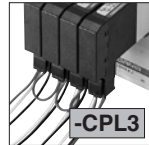

DIN connector type with indicator^{Note8}



DIN connector type without connector^{Note8}

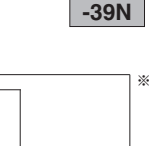

Individual air supply and exhaust spacer

- Blank: No spacer
- NP8: Individual air supply spacer (with φ 8 fitting)^{Note11}
- NP0: Individual air supply spacer (with φ 10 fitting)^{Note11}
- NR8: Individual exhaust spacer (with φ 8 fitting)^{Note11}
- NR0: Individual exhaust spacer (with φ 10 fitting)^{Note11}

For details, see p. 25.

Manifold fitting specification

- J5: With single use φ 8 fitting block^{Note9} (base piping type)
- J6: With single use φ 10 fitting block^{Note9} (base piping type)
- MH: With female thread NPT1/4 block^{Note10} (base piping type)

^{*} 300 mm = 11.8 in.
^{*} 3000 mm = 118 in.

Valve size	Valve units	Manifold type	Manifold outlet specification	Pilot specification	Station	Valve size	Valve specification	Operation type	Manual override	Valve outlet type	Wiring specification	Manifold fitting specification	Individual air supply and exhaust spacer	Voltage
Manifold model				Mounting valve model										
F18M	2 : : : 20	A	J M	Blank G	stn. 1 : : : stn. □ Note1	F18	T0 T1 T2 T3 T4 ^{Note6} T5 ^{Note6}	Blank ^{Note4} G ^{Note5} V ^{Note5}	Blank -R ^{Note2}	-A1 Note3	Blank -PN -PS -PL -PS3 -PL3 -CPS -CPL -CPS3 -CPL3 -PS3 -39L ^{Note8} -39N ^{Note8}		Blank -NP8 ^{Note11} -NP0 ^{Note11} -NR8 ^{Note11} -NR0 ^{Note11}	DC24V DC12V AC100V
		A AH	L	Blank G	stn. 1 : : : stn. □ Note1	F18	T0 T1 T2 T3 T4 ^{Note6} T5 ^{Note6}	Blank ^{Note4} G ^{Note5} V ^{Note5}	Blank -R ^{Note2} -83 ^{Note7}	-A1 Note3	Blank -PN -PS -PL -PS3 -39L ^{Note8} -39N ^{Note8}	-J5 ^{Note9} -J6 ^{Note9} -MH ^{Note10}	Blank -NP8 ^{Note11} -NP0 ^{Note11} -NR8 ^{Note11} -NR0 ^{Note11}	DC24V DC12V AC100V ^{Note11} AC120V AC240V ^{Note7}

- Notes: 1. Valve mounting location is from the left, with the solenoid on top, and the 4(A), 2(B) ports side in front.
2. When the valve specification is T1 or T2, the manual override lever is placed only on the A side. This is not available with -39□.
3. Always enter -A1.
4. Cannot be mounted on the external pilot manifold.
5. Cannot be mounted on the internal pilot manifold.

6. Not available in the vacuum valves.
7. Only for wiring specification -39□.
8. Not available for valve specification T1. In addition, the valve is used only as a double solenoid for T2.
9. Can be selected only when the manifold type is A.
10. Can be selected only when the manifold type is AH.
11. Not available with DIN connectors (-39□).

Remark: Negative common specifications are also available as made to order products (add -129W to the ends of the valve and manifold model order codes). For details, consult us.

F18 Series Monoblock Manifold A Type Additional Parts Order Codes

Gasket (gasket and exhaust valve)

F18 Z - GS1

Individual air supply and exhaust spacer (Spacer for non-plug-in type, gasket, exhaust valve, and 2 mounting screws)

F18 Z -

Specification

- NP8** : Individual air supply spacer (with ϕ 8 fitting)
- NP0** : Individual air supply spacer (with ϕ 10 fitting)
- NR8** : Individual exhaust spacer (with ϕ 8 fitting)
- NR0** : Individual exhaust spacer (with ϕ 10 fitting)

※For details, see p. 25.
 ※Not available with DIN connectors (-39).

Block-off plate (block-off plate and 2 mounting screws)

F18 BP

Connector-related order codes

FZ -

Valve specification

Blank: For **T1, T2, T3, T4, T5**
0: For **T0**

Connector specification

- CP** : Connector, lead wire length 300 mm [11.8 in.]
- CP3** : Connector, lead wire length 3000 mm [118 in.]
- CLN** : Connector without lead wire (short bar and contacts included)
- PA** : Positive common A type, lead wire length 300 mm [11.8 in.]※
- PA3** : Positive common A type, lead wire length 3000 mm [118 in.]※
- PB** : Positive common B type, lead wire length 300 mm [11.8 in.]※
- PB3** : Positive common B type, lead wire length 3000 mm [118 in.]※
- PC** : Positive common C type, lead wire length 300 mm [11.8 in.]※
- PC3** : Positive common C type, lead wire length 3000 mm [118 in.]※
- CC1.5** : Cabtyre cable, length 1500 mm [59 in.]^{Note}※
- CC3** : Cabtyre cable, length 3000 mm [118 in.]^{Note}※

※For details, see p. 19.

Note: Not available for **T0**

Muffler

KM - J

Fitting size

- 8**: Outer diameter ϕ 8 (for individual exhaust spacer)
 - 10**: Outer diameter ϕ 10 (for individual exhaust spacer)
- (Sales unit: Set of 10 mufflers)

● Common connector assembly

A type: FZ-PA※

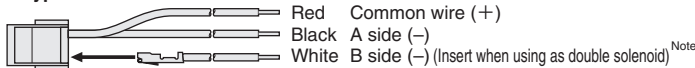

B type: FZ-PB※

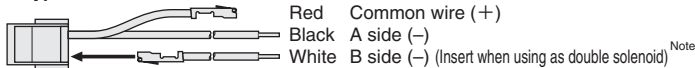

C type: FZ-PC※

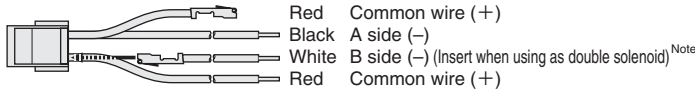

※ Lead wire length **Blank**: 300 mm [11.8 in.] Note: White lead wire is not available for **FZ0-P**.
3: 3000 mm [118 in.]

Manifold Order Code Example

(6 units of F18 Series)

F18M6AL

- stn.1~2 F18T0-A1-PS-J5 DC24V
- stn.3~5 F18T2-A1-PS-J6 DC24V
- stn.6 F18BP-J6

Precautions for Order Codes

● Manifold outlet specification

Select from among "dual use fitting blocks", "with female thread blocks" or "with selectable fittings." For repair or replacement, purchase the single valve unit additional parts, **F18Z-J** (dual use fitting block), **F18Z-J** (single use fitting block), or **F18Z-M** (female thread block), on p. 73.

● Orders for valves only

Place orders from "F18 Series Single Valve Unit Order Codes" on p. 72. Note, however, that the only available valve outlet type is **A1**. In addition, for common terminal wiring connections, order the common connector assemblies listed above separately.

F18 Series Monoblock Manifold F Type (Direct Piping Type) Order Codes

Valve size

F18M

18 mm [0.709 in.] width

Valve specification

- T0: 2-position, for single solenoid only
- T1: 2-position, single solenoid specification
- T2: 2-position, double solenoid specification
- T3: 3-position, closed center
- T4: 3-position, exhaust center
- T5: 3-position, pressure center

Manual override

Manual override button



No protrusion with DIN connector

Manual override lever^{Note2}



Protruding locking type^{Note3}



Valve outlet type

- FJ** With dual use ϕ 8, ϕ 10 fitting block^{Note5} (direct piping type)
- FJ5** With single use ϕ 8 fitting block^{Note5} (direct piping type)
- FJ6** With single use ϕ 10 fitting block^{Note5} (direct piping type)
- FM** With Rc1/4 female thread block^{Note5} (direct piping type)
- FMH** With NPT1/4 female thread block^{Note6} (direct piping type)

Wiring specification

L type plug connector
Without connector



S type plug connector
Without connector



S type plug connector
Lead wire 300 mm^{*}



L type plug connector
Lead wire 300 mm^{*}



S type plug connector
Lead wire 3000 mm^{*}



L type plug connector
Lead wire 3000 mm^{*}



Pre-wired positive common terminal
S type plug connector
Lead wire 300 mm^{*}

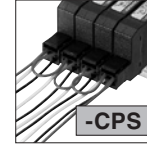

Pre-wired positive common terminal
L type plug connector
Lead wire 300 mm^{*}

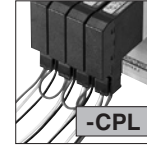

Pre-wired positive common terminal
S type plug connector
Lead wire 3000 mm^{*}

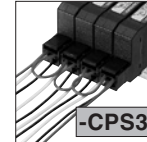

Pre-wired positive common terminal
L type plug connector
Lead wire 3000 mm^{*}

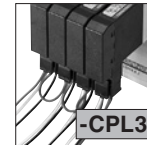

^{*} 300 mm = 11.8 in.
3000 mm = 118 in.

DIN connector type
with indicator^{Note4}



DIN connector type
without connector^{Note4}

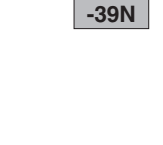

Individual air supply and exhaust spacer

- Blank : No spacer
 - NP8 : Individual air supply spacer (with ϕ 8 fitting)^{Note7}
 - NP0 : Individual air supply spacer (with ϕ 10 fitting)^{Note7}
 - NR8 : Individual exhaust spacer (with ϕ 8 fitting)^{Note7}
 - NR0 : Individual exhaust spacer (with ϕ 10 fitting)^{Note7}
- For details, see p. 25.

Valve size	Valve units	Manifold type	Station	Valve size	Valve specification	Manual override	Valve outlet type	Wiring specification	Individual air supply and exhaust spacer	Voltage	
Manifold model		Mounting valve model									
F18M	2 . . . 20	F FH	stn. 1 . . . stn. <input type="checkbox"/> ^{Note1}	F18	T0 T3 T1 T4 T2 T5	Blank -R ^{Note2} -83 ^{Note3}	-FJ ^{Note5} -FJ5 ^{Note5} -FJ6 ^{Note5} -FM ^{Note5} -FMH ^{Note6}	Blank -PN -PS -PL -PS3 -PL3	-CPS -CPL -CPS3 -CPL3 -39L ^{Note4} -39N ^{Note4}	Blank -NP8 ^{Note7} -NP0 ^{Note7} -NR8 ^{Note7} -NR0 ^{Note7}	DC24V DC12V AC100V ^{Note7} AC120V AC240V ^{Note3}
BP (for block-off plate)											

Notes: 1. Valve mounting location is from the left, with the solenoid on top, and the 4(A), 2(B) ports side in front.
2. When the valve specification is T1 or T2, the manual override lever is placed only on the A side. This is not available with -39□.
3. Only for wiring specification -39□.

4. Not available for valve specification T1. In addition, the valve is used only as a double solenoid for T2.
5. Can be selected only when the manifold type is F.
6. Can be selected only when the manifold type is FH.
7. Not available with DIN connectors (-39□).
Remarks: 1. The external pilot valve cannot be mounted on the F type manifold.
2. Negative common specifications are also available as made to order products (add -129W to the ends of the valve and manifold model order codes). For details, consult us.

F18 Series Monoblock Manifold F Type Additional Parts Order Codes

Gasket (gasket and exhaust valve)

F18 Z - GS1

Individual air supply and exhaust spacer (Spacer for non-plug-in type, gasket, exhaust valve, and 2 mounting screws)

F18 Z -

Specification

- NP8** : Individual air supply spacer (with ϕ 8 fitting)
- NP0** : Individual air supply spacer (with ϕ 10 fitting)
- NR8** : Individual exhaust spacer (with ϕ 8 fitting)
- NR0** : Individual exhaust spacer (with ϕ 10 fitting)

Block-off plate (block-off plate and 2 mounting screws)

F18 BP

※For details, see p. 25.

※Not available with DIN connectors (-39).

Connector-related order codes

FZ -

Valve specification

Blank: For **T1, T2, T3, T4, T5**
0: For **T0**

Connector specification

- CP** : Connector, lead wire length 300 mm [11.8 in.]
- CP3** : Connector, lead wire length 3000 mm [118 in.]
- CLN** : Connector without lead wire (short bar and contacts included)
- PA** : Positive common A type, lead wire length 300 mm [11.8 in.] ※
- PA3** : Positive common A type, lead wire length 3000 mm [118 in.] ※
- PB** : Positive common B type, lead wire length 300 mm [11.8 in.] ※
- PB3** : Positive common B type, lead wire length 3000 mm [118 in.] ※
- PC** : Positive common C type, lead wire length 300 mm [11.8 in.] ※
- PC3** : Positive common C type, lead wire length 3000 mm [118 in.] ※
- CC1.5** : Cabtyre cable, length 1500 mm [59 in.]^{Note} ※
- CC3** : Cabtyre cable, length 3000 mm [118 in.]^{Note} ※

※For details, see p. 19.

Note: Not available for **T0**

Muffler

KM - J

Fitting size

- 8**: Outer diameter ϕ 8 (for individual exhaust spacer)
 - 10**: Outer diameter ϕ 10 (for individual exhaust spacer)
- (Sales unit: Set of 10 mufflers)

Common connector assembly

A type: FZ-PA ※

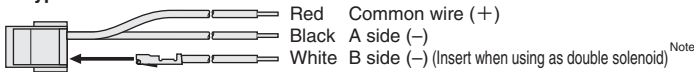

B type: FZ-PB ※

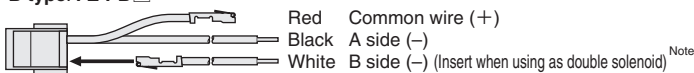

C type: FZ-PC ※

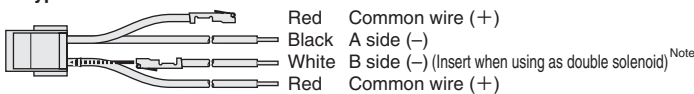

※ Lead wire length **Blank**: 300 mm [11.8 in.] **3**: 3000 mm [118 in.] **Note**: White lead wire is not available for **FZ0-P**.

Manifold Order Code Example

(4 units of F18 Series)

F18M4F

- stn.1~2 **F18T0-FJ5-PS DC24V**
- stn.3 **F18T2-FJ6-PS DC24V**
- stn.4 **F18BP**

Precautions for Order Codes

Orders for valves only

Place orders from "F18 Series Single Valve Unit Order Codes" on p. 72.

Select from valve outlet types **-FJ, -FJ5, -FJ6**, or **-FM**. In addition, for common terminal wiring connections, order the common connector assemblies listed above separately.

F18 Series Split Manifold Non-Plug-in Type Order Codes

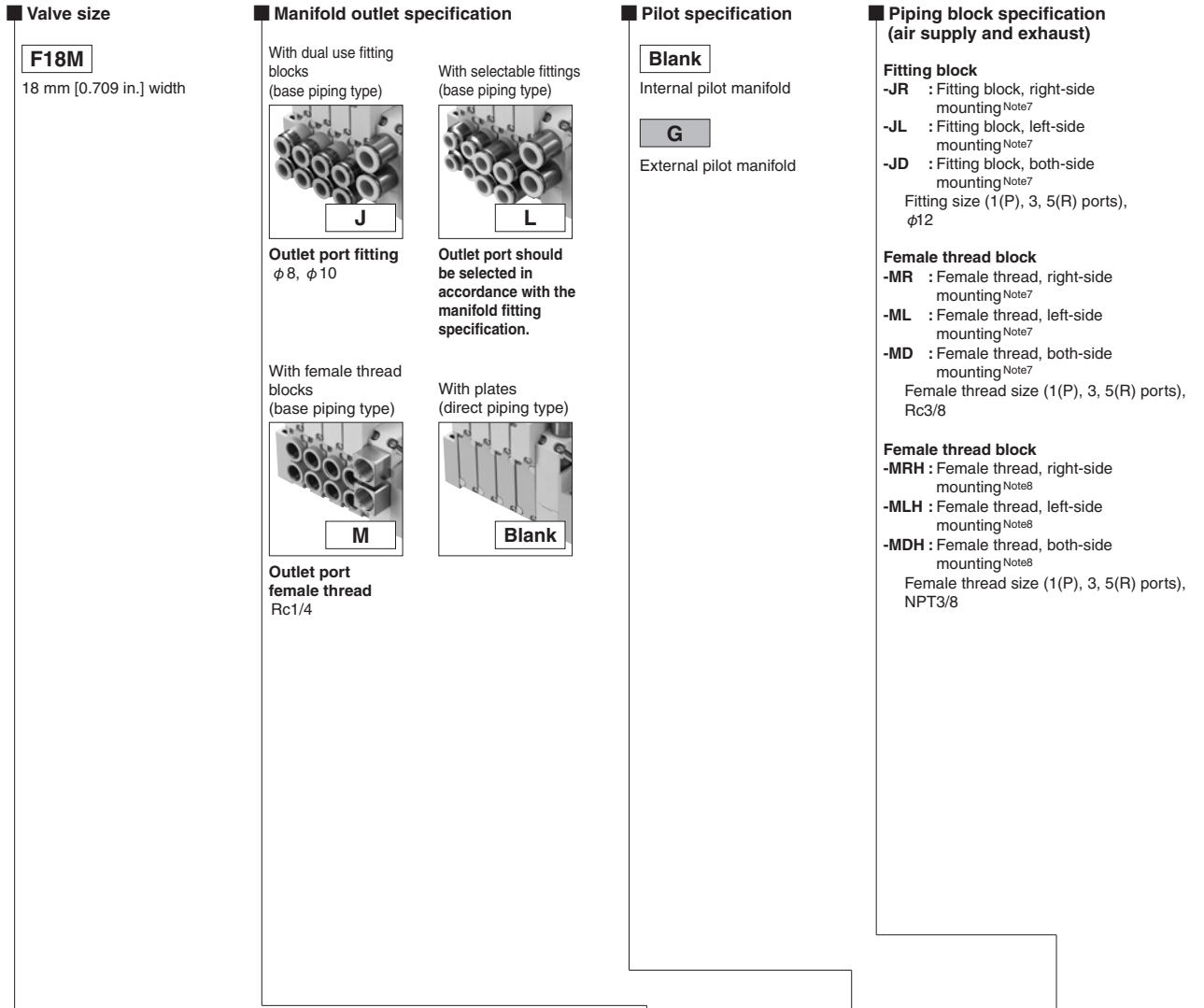

Valve size	Valve units	Manifold type	Manifold outlet specification	Pilot specification	Piping block specification
Manifold model					

Base piping type	F18M	2 ⋮ 20	N	J M	Blank G	-JR -JL -JD	-MR -ML -MD	
Base piping type selectable fitting			N NH	L	Blank G	-JR ^{Note7} -JL ^{Note7} -JD ^{Note7}	-MR ^{Note7} -ML ^{Note7} -MD ^{Note7}	-MRH ^{Note8} -MLH ^{Note8} -MDH ^{Note8}
Direct piping type			Blank	Blank G	-JR ^{Note7} -JL ^{Note7} -JD ^{Note7}	-MR ^{Note7} -ML ^{Note7} -MD ^{Note7}	-MRH ^{Note8} -MLH ^{Note8} -MDH ^{Note8}	

Remark: Negative common specifications are also available as made to order products (add **-129W** to the ends of the valve and manifold model order codes). For details, consult us.

Valve specification

- T0** : 2-position, for single solenoid only
- T1** : 2-position, single solenoid specification
- T2** : 2-position, double solenoid specification
- T3** : 3-position, closed center
- T4** : 3-position, exhaust center
- T5** : 3-position, pressure center

Operation type

- Blank**
Internal pilot type^{Note5}
- G**
External pilot type^{Note6}
(for positive pressure)
※ No vacuum valve can be mounted.

Valve outlet type

- A1** With plate^{Note3}
(base piping type)
- FJ** With dual use $\phi 8$, $\phi 10$ fitting block^{Note7}
(direct piping type)
- FJ5** With single use $\phi 8$ fitting block^{Note7} (direct piping type)
- FJ6** With single use $\phi 10$ fitting block^{Note7} (direct piping type)
- FM** With Rc1/4 female thread block^{Note7} (direct piping type)
- FMH** With NPT1/4 female thread block^{Note8} (direct piping type)

Manual override

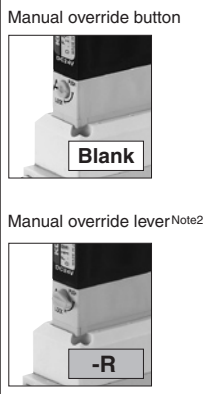

Wiring specification



Manifold fitting specification

- J5** With single use $\phi 8$ fitting block^{Note7}
(base piping type)
- J6** With single use $\phi 10$ fitting block^{Note7}
(base piping type)
- MH** With NPT1/4 female thread block^{Note8}
(base piping type)

Individual air supply and exhaust spacer

- Blank** : No spacer
 - NP8** : Individual air supply spacer
(with $\phi 8$ fitting)
 - NP0** : Individual air supply spacer
(with $\phi 10$ fitting)
 - NR8** : Individual exhaust spacer
(with $\phi 8$ fitting)
 - NR0** : Individual exhaust spacer
(with $\phi 10$ fitting)
- For details, see p. 25.

Port isolator

- Blank** : No port isolator
- SP** : For 1(P) port^{Note4}
- SR** : For 3(R2), 5(R1) ports^{Note4}
- SA** : For 1(P), 3(R2), and 5(R1) ports^{Note4}

Station	Valve size	Valve specification	Operation type	Manual override	Valve outlet type	Wiring specification	Manifold fitting specification	Individual air supply and exhaust spacer	Port isolator	Voltage
Mounting valve model										
stn. 1 ⋮ stn. □ <small>Note1</small>	F18	T0 T3 T1 T4 T2 T5	Blank ^{Note5}	Blank	-A1 ^{Note3}	-PN -PS -PS3 -CPS -CPS3	Blank -NP8 -NR8 -NP0 -NR0	Blank -SP ^{Note4} -SR ^{Note4} -SA ^{Note4}	DC24V DC12V AC100V AC120V	
			G ^{Note6}	-R ^{Note2}						BPN (for block-off plate)
stn. 1 ⋮ stn. □ <small>Note1</small>	F18	T0 T3 T1 T4 T2 T5	Blank ^{Note5}	Blank	-A1 ^{Note3}	-PN -PS -PS3 -CPS -CPS3	-J5 ^{Note7} -J6 ^{Note7} -MH ^{Note8}	Blank -NP8 -NR8 -NP0 -NR0	Blank -SP ^{Note4} -SR ^{Note4} -SA ^{Note4}	DC24V DC12V AC100V AC120V
			G ^{Note6}	-R ^{Note2}						
stn. 1 ⋮ stn. □ <small>Note1</small>	F18	T0 T3 T1 T4 T2 T5	Blank ^{Note5}	Blank	-FJ ^{Note7} -FJ5 ^{Note7} -FJ6 ^{Note7} -FM ^{Note7} -FMH ^{Note8}	-PN -PS -PS3 -CPS -CPS3	Blank -NP8 -NR8 -NP0 -NR0	Blank -SP ^{Note4} -SR ^{Note4} -SA ^{Note4}	DC24V DC12V AC100V AC120V	
			G ^{Note6}	-R ^{Note2}						BPN (for block-off plate)

Notes: 1. Valve mounting location is from the left, with the solenoid on top, and the 4(A), 2(B) ports side in front.
 2. When the valve specification is T1 or T2, the manual override lever is placed only on the A side.
 3. When selecting J, M, or L (base piping type) for the manifold outlet specification, always enter -A1 (with plate) for the valve outlet type.
 4. Port isolators can be installed only when piping blocks are mounted on both sides. In addition, only 1 port isolator can be mounted in 1 manifold for -SA, or 1 each port isolator for -SP and -SR for a total of 2 locations. When shipping, the designated port isolators are mounted between the designated station and the station to its immediate left (the next smaller stn. No.).
 5. Cannot be mounted on the external pilot manifold.
 6. Cannot be mounted on the internal pilot manifold.
 7. Can be selected only when the manifold type is N.
 8. Can be selected only when the manifold type is NH.

F18 Series Split Manifold Non-Plug-in Type Additional Parts Order Codes

Parts for manifold

F18 Z -

Parts content

- GS2** : Gasket (gasket and exhaust valve)
- SP** : Port isolator (for 1(P) port)
- SR** : Port isolator (for 3(R2), 5(R1) ports)
- SA** : Port isolator (for 1(P), 3(R2), 5(R1) ports)

Piping block assembly

F18 Z -

Piping specification

- PJ** : Fitting piping block
- PM** : Rc3/8 female thread piping block
- PMH** : NPT3/8 female thread piping block

Pilot specification

- Blank** : Internal pilot
- G** : External pilot

Block-off plate (block-off plate, 2 mounting screws)

F18 BP N

For non-plug-in type

End blocks (one set of left and right)

F18 Z - E

Connector-related order codes

FZ -

300 mm = 11.8 in.
1500 mm = 59 in.
3000 mm = 118 in.

Valve specification

Blank: For T1, T2, T3, T4, T5
0: For T0

※For details, see p. 19.

Connector specification

- CP** : Connector, lead wire length 300 mm
- CP3** : Connector, lead wire length 3000 mm
- CLN** : Connector without lead wire (short bar, contacts included)
- PA** : Positive common A type, lead wire length 300 mm *
- PA3** : Positive common A type, lead wire length 3000 mm *
- PB** : Positive common B type, lead wire length 300 mm *
- PB3** : Positive common B type, lead wire length 3000 mm *
- PC** : Positive common C type, lead wire length 300 mm *
- PC3** : Positive common C type, lead wire length 3000 mm *
- CC1.5** : Cabtyre cable, length 1500 mm ^{Note} *
- CC3** : Cabtyre cable, length 3000 mm ^{Note} *

Note: Not available for T0

Individual air supply and exhaust spacer (Spacer for non-plug-in type, gasket, exhaust valve, and 2 mounting screws)

F18 Z -

Specification

- NP8** : Individual air supply spacer (with ϕ 8 fitting)
- NP0** : Individual air supply spacer (with ϕ 10 fitting)
- NR8** : Individual exhaust spacer (with ϕ 8 fitting)
- NR0** : Individual exhaust spacer (with ϕ 10 fitting)

※For details, see p. 25.

Muffler

KM - J

Fitting size

- 8**: Outer diameter ϕ 8 (for individual exhaust spacer)
 - 10**: Outer diameter ϕ 10 (for individual exhaust spacer)
 - 12**: Outer diameter ϕ 12
- (Sales unit: Set of 10 mufflers)

Common connector assembly

A type: FZ-PA *

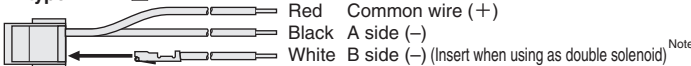

B type: FZ-PB *

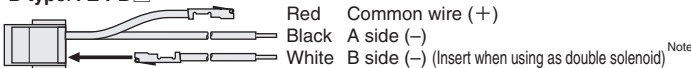

C type: FZ-PC *

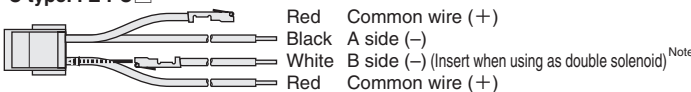

※ Lead wire length **Blank**: 300 mm [11.8 in.] **3**: 3000 mm [118 in.] Note: White lead wire is not available for FZ0-P .

Connecting rod

F18 Z - -

Additional unit number

01~20 (01~04 for RH)

※For reduction of units, consult us.

Specification

- RV** : For valve base
- RH** : For piping and wiring base

Valve base assembly (valve base and gasket)

F18 Z -

Piping specification

- VJ** : Dual use fitting valve base
- VJ5** : Single use ϕ 8 fitting valve base
- VJ6** : Single use ϕ 10 fitting valve base
- VM** : Rc1/4 female thread valve base
- VMH** : NPT1/4 female thread valve base
- VP** : Valve base plate

Manifold Order Code Example

(4 units of F18 Series)

F18M4NL-JR

- stn.1~2 F18T0-A1-PS-J5 DC24V
- stn.3 F18T2-A1-PS-J6 DC24V
- stn.4 F18BPN-J6

Precautions for Order Codes

Orders for valves only

Place orders from "F18 Series Single Valve Unit Order Codes" on p. 72. However, **Blank**, **A2** , **F3**, **F4** , **F5**, and **F6**, cannot be selected for the valve outlet type. And for the wiring specification, **Blank**, **PL**, and **PL3** cannot be selected. In addition, for common terminal wiring connections, separately order the common connector assemblies listed on the left.

F18 Series Split Manifold Plug-in Type Order Codes

Manifold outlet specification

With dual use fitting blocks (base piping type)

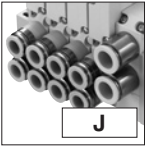

J

Outlet port fitting
φ 8, φ 10

With selectable fittings (base piping type)

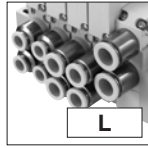

L

Outlet port should be selected in accordance with the manifold fitting specification.

With female thread blocks (base piping type)

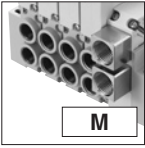

M

Outlet port female thread
Rc1/4

With plates (direct piping type)

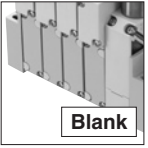

Blank

Valve size

F18M

18 mm [0.709 in.] width

Pilot specification

Blank

Internal pilot manifold

G

External pilot manifold

Piping block specification (air supply and exhaust)

Fitting block

-JR : Fitting block, right-side mounting^{Note11}

-JL : Fitting block, left-side mounting^{Note11}

-JD : Fitting block, both-side mounting^{Note11}

Fitting size (1(P), 3, 5(R) ports), φ 12

Female thread block

-MR : Female thread, right-side mounting^{Note11}

-ML : Female thread, left-side mounting^{Note11}

-MD : Female thread, both-side mounting^{Note11}

Female thread size (1(P), 3, 5(R) ports), Rc3/8

Female thread block

-MRH : Female thread, right-side mounting^{Note12}

-MLH : Female thread, left-side mounting^{Note12}

-MDH : Female thread, both-side mounting^{Note12}

Female thread size (1(P), 3, 5(R) ports), NPT3/8

Wiring specification (wiring block)

Flat cable connector (with socket and strain relief)

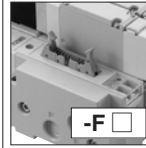

-F

-F100 : 10-pin

-F101 : 10-pin

-F200 : 20-pin

-F201 : 20-pin

-F260 : 26-pin

For details, see p. 92-96.

D-sub connector

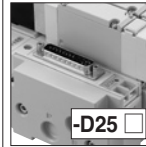

-D25

(M2.6 mounting screws)

-D250 : 25-pin^{Note11}

-D251 : 25-pin^{Note11}

(4-40UNC mounting screws)

-D250U : 25-pin^{Note12}

-D251U : 25-pin^{Note12}

-D370NU : 37-pin, no-power terminal^{Note12}

For details, see p. 92-96.

Terminal block (19 terminals, M3 screws)

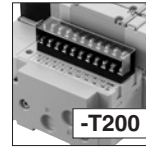

-T200

Also can provide the terminal block with cover.^{Note3}

Wiring connection specification

Blank

Packed wiring: Wiring is made in accordance with the mounted valve specifications.

-W

Double wiring: Wiring is always for the double solenoid, regardless of the specifications of the mounted valve.

Wiring position (wiring block)

Blank: Left-side mounting

-R : Right-side mounting

Valve size	Valve units	Manifold type	Manifold outlet specification	Pilot specification	Piping block specification	Wiring specification	Wiring connection specification	Wiring position	Voltage
Manifold model									

Base piping type	F18M	2 : : : □ Note1	P	J M	Blank G	-JR -MR -JL -ML -JD -MD	-F100 -D250 -F101 -D251 -F200 -T200 -F201 -F260	Blank -W	Blank -R	DC24V DC12V AC100V ^{Note2} AC120V ^{Note2}
Base piping type selectable fitting			L	Blank G	-JR ^{Note11} -MD ^{Note11} -JL ^{Note11} -MRH ^{Note12} -JD ^{Note11} -MLH ^{Note12} -MR ^{Note11} -MDH ^{Note12} -ML ^{Note11}	-F100 -D251 ^{Note11} -F101 -D250U ^{Note12} -F200 -D251U ^{Note12} -F201 -D370NU ^{Note12} -F260 -T200 -D250 ^{Note11}	Blank -W	Blank -R	DC24V DC12V AC100V ^{Note2} AC120V ^{Note2}	
Direct piping type			PH	Blank	Blank G	-JR ^{Note11} -MD ^{Note11} -JL ^{Note11} -MRH ^{Note12} -JD ^{Note11} -MLH ^{Note12} -MR ^{Note11} -MDH ^{Note12} -ML ^{Note11}	-F100 -D251 ^{Note11} -F101 -D250U ^{Note12} -F200 -D251U ^{Note12} -F201 -D370NU ^{Note12} -F260 -T200 -D250 ^{Note11}	Blank -W	Blank -R	DC24V DC12V AC100V ^{Note2} AC120V ^{Note2}

Notes: 1. For the maximum number of units, see the table for maximum number of valve units by wiring specification, on p. 84.
2. AC100V, AC120V is available only for the -D250 □, -D251 □, -D370NU (D-sub connector) and -T200 (terminal block) wiring specifications.
3. The terminal block with cover is also available as a made to order product (add -139W to the end of the manifold model order code).
For details, consult us.

Remark: Negative common specifications are also available as made to order products (add -129W to the ends of the valve and manifold model order codes).
For details, consult us.

Valve specification

- T0** : 2-position, for single solenoid only
- T1** : 2-position, single solenoid specification
- T2** : 2-position, double solenoid specification
- T3** : 3-position, closed center
- T4** : 3-position, exhaust center
- T5** : 3-position, pressure center

Operation type

Blank

Internal pilot type ^{Note9}

G

External pilot type ^{Note10}
(for positive pressure)
※ No vacuum valve can be mounted.

Valve outlet type

- A1** With plate ^{Note5}
(base piping type)
- FJ** With dual use ϕ 8, ϕ 10 fitting block ^{Note11}
(direct piping type)
- FJ5** With single use ϕ 8 fitting block ^{Note11}
(direct piping type)
- FJ6** With single use ϕ 10 fitting block ^{Note11}
(direct piping type)
- FM** With Rc1/4 female thread block ^{Note11}
(direct piping type)
- FMH** With NPT1/4 female thread block ^{Note12}
(direct piping type)

Manual override

Manual override button



Manual override lever ^{Note7}



Manifold fitting specification

- J5** With single use ϕ 8 fitting block ^{Note11}
(base piping type)
- J6** With single use ϕ 10 fitting block ^{Note11}
(base piping type)
- MH** With NPT1/4 female thread block ^{Note12}
(base piping type)

Individual air supply and exhaust spacer

- Blank** : No spacer
 - PP8** : Individual air supply spacer
(with ϕ 8 fitting)
 - PP0** : Individual air supply spacer
(with ϕ 10 fitting)
 - PR8** : Individual exhaust spacer
(with ϕ 8 fitting)
 - PR0** : Individual exhaust spacer
(with ϕ 10 fitting)
- For details, see p. 25.

Port isolator

- Blank** : No port isolator
- SP** : For 1(P) port ^{Note8}
- SR** : For 3(R2), 5(R1) ports ^{Note8}
- SA** : For 1(P), 3(R2), 5(R1) ports ^{Note8}

Station	Valve size	Valve specification	Operation type	Manual override	Valve outlet type	Manifold fitting specification	Individual air supply and exhaust spacer	Port isolator	Voltage
Mounting valve model									
stn. 1 ⋮ stn. □ <small>Note4</small>	F18	T0 T3 T1 T4 T2 T5	Blank ^{Note9} G ^{Note10}	Blank -R ^{Note7}	-A1 ^{Note5}		Blank -PP8 -PR8 -PP0 -PR0	Blank -SP ^{Note8} -SR ^{Note8} -SA ^{Note8}	DC24V DC12V AC100V ^{Note2} AC120V ^{Note2}
		BPP (for block-off plate)^{Note6}							
stn. 1 ⋮ stn. □ <small>Note4</small>	F18	T0 T3 T1 T4 T2 T5	Blank ^{Note9} G ^{Note10}	Blank -R ^{Note7}	-A1 ^{Note5}	-J5 ^{Note11} -J6 ^{Note11} -MH ^{Note12}	Blank -PP8 -PR8 -PP0 -PR0	Blank -SP ^{Note8} -SR ^{Note8} -SA ^{Note8}	DC24V DC12V AC100V ^{Note2} AC120V ^{Note2}
		BPP (for block-off plate)^{Note6}							
stn. 1 ⋮ stn. □ <small>Note4</small>	F18	T0 T3 T1 T4 T2 T5	Blank ^{Note9} G ^{Note10}	Blank -R ^{Note7}	-FJ ^{Note11} -FJ5 ^{Note11} -FJ6 ^{Note11} -FM ^{Note11} -FMH ^{Note12}		Blank -PP8 -PR8 -PP0 -PR0	Blank -SP ^{Note8} -SR ^{Note8} -SA ^{Note8}	DC24V DC12V AC100V ^{Note2} AC120V ^{Note2}
		BPP (for block-off plate)^{Note6}							

Notes: 4. Valve mounting location is from the left, with the solenoid on top, and the 4(A), 2(B) ports side in front.
 5. When selecting J, M, or L (base piping type) for the manifold outlet specification, always enter -A1 (with plate) for the valve outlet type.
 6. Caution should be exercised that the block-off plate wiring is always double wiring (allocated 2 control pins at 1 stn.), regardless of the wiring connection specification. For wiring for a single solenoid, see p. 85.
 7. When the valve specification is T1 or T2, the manual override lever is placed only on the A side.
 8. Port isolators can be installed only when piping blocks are mounted on both sides. In addition, only 1 port isolator can be mounted in 1 manifold for -SA, or 1 each port isolator for -SP and -SR for a total of 2 locations. When shipping, the designated port isolators are mounted between the designated station and the station to its immediate left (the next smaller stn. No.).
 9. Cannot be mounted on the external pilot manifold.
 10. Cannot be mounted on the internal pilot manifold.
 11. Can be selected only when the manifold type is P.
 12. Can be selected only when the manifold type is PH.

F18 Series Split Manifold Plug-in Type Additional Parts Order Codes

Parts for manifold

F18 Z -

Parts content

- GS2** : Gasket (gasket and exhaust valve)
- SP** : Port isolator (for 1(P) port)
- SR** : Port isolator (for 3(R2), 5(R1) ports)
- SA** : Port isolator (for 1(P), 3(R2), 5(R1) ports)

Block-off plate (block-off plate, 2 mounting screws, and plug)

F18 BP P

For plug-in type

Valve base assembly (valve base, gasket, lead wire, and plug-in connector)

F18 Z - -

Wiring specification

- D**: For D-sub connector
- F**: For flat cable connector, terminal block

Piping specification

- VJ** : Dual use fitting valve base
- VJ5** : Single use ϕ 8 fitting valve base
- VJ6** : Single use ϕ 10 fitting valve base
- VM** : Rc1/4 female thread valve base
- VMH** : NPT1/4 female thread valve base
- VP** : Valve base plate

Piping block assembly

F18 Z -

Piping specification

- PJP** : Fitting piping block
- PMP** : Rc3/8 female thread piping block
- PMPH** : NPT3/8 female thread piping block

Pilot specification

- Blank** : Internal pilot
- G** : External pilot

End blocks (one set of left and right)

F18 Z - EP

Wiring block assembly (one set)

F18 Z - -

Voltage (Not required for T200)

- DC24**
- DC12**
- AC100** (for **D250** , **D251** , **D370NU** only)

Piping specification

- F100** : Flat cable connector (DC specification)
- F101** : Flat cable connector (DC specification)
- F200** : Flat cable connector (DC specification)
- F201** : Flat cable connector (DC specification)
- F260** : Flat cable connector (DC specification)
- D250** : D-sub connector (M2.6 screws)
- D251** : D-sub connector (M2.6 screws)
- D250U** : D-sub connector (4-40UNC screws)
- D251U** : D-sub connector (4-40UNC screws)
- D370NU** : D-sub connector (4-40UNC screws), without power terminal
- T200L** : Terminal block for left-side mounting
- T200R** : Terminal block for right-side mounting

Individual air supply and exhaust spacer (Spacer for plug-in type, gasket, exhaust valve, and 2 mounting screws)

F18 Z -

Specification

- PP8** : Individual air supply spacer (with ϕ 8 fitting)
- PP0** : Individual air supply spacer (with ϕ 10 fitting)
- PR8** : Individual exhaust spacer (with ϕ 8 fitting)
- PR0** : Individual exhaust spacer (with ϕ 10 fitting)

※For details, see p. 25.

Muffler

KM - J

Fitting size

- 8**: Outer diameter ϕ 8 (for individual exhaust spacer)
 - 10**: Outer diameter ϕ 10 (for individual exhaust spacer)
 - 12**: Outer diameter ϕ 12
- (Sales unit: Set of 10 mufflers)

Connecting rod

F18 Z - -

Number of additional units

- 01~20 (01~04 for RH)**
- ※Example: To add 2 valve units, enter **-02**.
- ※For reduction of units, consult us.

Specification

- RV** : For valve base
- RH** : For piping and wiring base

Table for maximum number of valve units by wiring specification

		Maximum number of units	
		Wiring connection specification	
Wiring specification	Max. outputs	Packed wiring (Blank)	Double wiring (-W)
F100 Flat cable (10P)	8	Varies depending on the number of mounted single solenoids, double solenoids, and block-off plates. The number of controlled solenoids should be designated as the maximum number of outputs or less. D370NU is a maximum of 20 units.	4 units
F101 Flat cable (10P)	8		4 units
F200 Flat cable (20P)	16		8 units
F201 Flat cable (20P)	16		8 units
F260 Flat cable (26P)	20		10 units
D250 <input type="checkbox"/> D-sub connector (25P)	16		8 units
D251 <input type="checkbox"/> D-sub connector (25P)	20		10 units
D370NU D-sub connector (37P)	32		16 units
T200 Terminal block (19 terminals)	18		9 units

Manifold Order Code Example

(12 units of F18 Series)

F18M12PL-JR-F201 DC24V

stn.1~8 F18T0-A1-J5 DC24V
stn.9~11 F18T2-A1-J6 DC24V
stn.12 F18BPP-J6

Precautions for Order Codes

● Orders for valves only

Place orders from "F18 Series Single Valve Unit Order Codes" on p. 72.

However, **Blank**, **A2**□, **F3**, **F4**□, **F5**, and **F6** cannot be selected for the valve outlet type. For the wiring specification, **Blank** is the only selection.

● Wiring connection specification

Blank (packed wiring): Wiring is made in accordance with the mounted valve specifications.

-W (double wiring): Wiring is always for the double solenoid, regardless of the specifications of the mounted valve.

Caution

Caution should be exercised that the block-off plate wiring is always double wiring (allocated 2 control pins at 1 stn.), regardless of the wiring connection specification. The block-off plate wiring can be made as wiring for a single solenoid. Add **-1W** to the end of the block-off plate order code in the case. For details, consult us.

F18 Series Serial Transmission Compatible Manifold Order Codes

Manifold outlet specification

With dual use fitting blocks (base piping type)

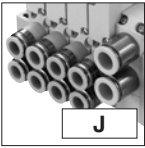

J

Outlet port fitting
φ 8, φ 10

With selectable fittings (base piping type)

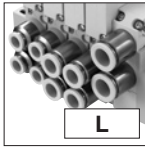

L

Outlet port should be selected in accordance with the manifold fitting specification.

With female thread blocks (base piping type)

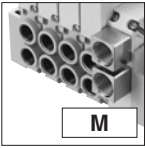

M

Outlet port female thread
Rc1/4

With plates (direct piping type)

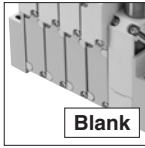

Blank

Valve size

F18M

18 mm [0.709 in.] width

Pilot specification

Blank

Internal pilot manifold

G

External pilot manifold

Piping block specification (air supply and exhaust)

Fitting block

-JR : Fitting block, right-side mounting^{Note10}

-JL : Fitting block, left-side mounting^{Note10}

-JD : Fitting block, both-side mounting^{Note10}

Fitting size (1(P), 3, 5(R) ports), φ12

Female thread block

-MR : Female thread, right-side mounting^{Note10}

-ML : Female thread, left-side mounting^{Note10}

-MD : Female thread, both-side mounting^{Note10}

Female thread size (1(P), 3, 5(R) ports), Rc3/8

Female thread block

-MRH : Female thread, right-side mounting^{Note11}

-MLH : Female thread, left-side mounting^{Note11}

-MDH : Female thread, both-side mounting^{Note11}

Female thread size (1(P), 3, 5(R) ports), NPT3/8

Transmission block specification

※ These are the serial transmission block specifications compatible with each system.



● Block photoed on right is compatible with CompoNet.
For details, see p. 37, 40.

-31 : For OMRON B7A Link Terminal (standard)

-32 : For OMRON B7A Link Terminal (high speed)

-A1 : For OMRON CompoBus/S (16 outputs)

-B1 : For CC-Link (16 outputs)

-H1 : For CompoNet (16 outputs)^{Note2}

Wiring connection specification

Blank

Packed wiring: Wiring is made in accordance with the mounted valve specifications.

-W

Double wiring: Wiring is always for the double solenoid, regardless of the specifications of the mounted valve.

Wiring position (transmission block)

Blank : Left-side mounting

-R : Right-side mounting^{Note2}

Valve size	Valve units	Manifold type	Manifold outlet specification	Pilot specification	Piping block specification	Transmission block specification	Wiring connection specification	Wiring position
Manifold model								

Base piping type	F18M	2 : : : □ Note1	S	J M	Blank G	-JR -JL -JD -MR -ML -MD	-31 -32 -A1 -B1 -H1 ^{Note2}	Blank -W	Blank -R ^{Note2}
Base piping type selectable fitting			L	Blank G	-JR ^{Note10} -JL ^{Note10} -JD ^{Note10} -MR ^{Note10} -ML ^{Note10}	-MD ^{Note10} -MRH ^{Note11} -MLH ^{Note11} -MDH ^{Note11}	-31 -32 -A1 -B1 -H1 ^{Note2}	Blank -W	Blank -R ^{Note2}
Direct piping type			SH	Blank	Blank G	-JR ^{Note10} -JL ^{Note10} -JD ^{Note10} -MR ^{Note10} -ML ^{Note10}	-MD ^{Note10} -MRH ^{Note11} -MLH ^{Note11} -MDH ^{Note11}	-31 -32 -A1 -B1 -H1 ^{Note2}	Blank -W

Notes: 1. To determine the maximum number of units, see the table for maximum number of valve units by transmission block specification, on p. 88.
2. The -H1 (for CompoNet (16 outputs)) transmission block is mountable on the left side only.

Valve specification

- T0** : 2-position, for single solenoid only
- T1** : 2-position, single solenoid specification
- T2** : 2-position, double solenoid specification
- T3** : 3-position, closed center
- T4** : 3-position, exhaust center
- T5** : 3-position, pressure center

Operation type

- Blank**
Internal pilot type Note8
- G**
External pilot type Note9
(for positive pressure)
※ No vacuum valve can be mounted.

Valve outlet type

- A1** With plate Note4
(base piping type)
- FJ** With dual use ϕ 8, ϕ 10 fitting block Note10
(direct piping type)
- FJ5** With single use ϕ 8 fitting block Note10
(direct piping type)
- FJ6** With single use ϕ 10 fitting block Note10
(direct piping type)
- FM** With Rc1/4 female thread block Note10
(direct piping type)
- FMH** With NPT1/4 female thread block Note11
(direct piping type)

Manual override

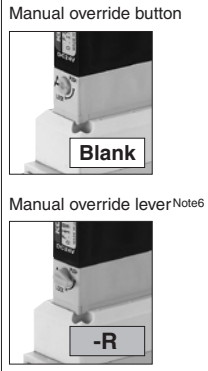

Manifold fitting specification

- J5** With single use ϕ 8 fitting block Note10
(base piping type)
- J6** With single use ϕ 10 fitting block Note10
(base piping type)
- MH** With NPT1/4 female thread block Note11
(base piping type)

Individual air supply and exhaust spacer

- Blank** : No spacer
 - PP8** : Individual air supply spacer (with ϕ 8 fitting)
 - PP0** : Individual air supply spacer (with ϕ 10 fitting)
 - PR8** : Individual exhaust spacer (with ϕ 8 fitting)
 - PR0** : Individual exhaust spacer (with ϕ 10 fitting)
- For details, see p. 25.

Port isolator

- Blank** : No port isolator
- SP** : For 1(P) port Note7
- SR** : For 3(R2), 5(R1) ports Note7
- SA** : For 1(P), 3(R2), 5(R1) ports Note7

Station	Valve size	Valve specification	Operation type	Manual override	Valve outlet type	Manifold fitting specification	Individual air supply and exhaust spacer	Port isolator	Voltage
Mounting valve model									
stn. 1 ⋮ stn. □ <small>Note3</small>	F18	T0 T3 T1 T4 T2 T5	Blank <small>Note8</small>	Blank	-A1 <small>Note4</small>		Blank -PP8 -PR8 -PP0 -PR0	Blank -SP <small>Note7</small> -SR <small>Note7</small> -SA <small>Note7</small>	DC24V
		BPP (for block-off plate) <small>Note5</small>							
stn. 1 ⋮ stn. □ <small>Note3</small>	F18	T0 T3 T1 T4 T2 T5	Blank <small>Note8</small>	Blank	-A1 <small>Note4</small>	-J5 <small>Note10</small> -J6 <small>Note10</small> -MH <small>Note11</small>	Blank -PP8 -PR8 -PP0 -PR0	Blank -SP <small>Note7</small> -SR <small>Note7</small> -SA <small>Note7</small>	DC24V
		BPP (for block-off plate) <small>Note5</small>							
stn. 1 ⋮ stn. □ <small>Note3</small>	F18	T0 T3 T1 T4 T2 T5	Blank <small>Note8</small>	Blank	-FJ <small>Note10</small> -FJ5 <small>Note10</small> -FJ6 <small>Note10</small> -FM <small>Note10</small> -FMH <small>Note11</small>		Blank -PP8 -PR8 -PP0 -PR0	Blank -SP <small>Note7</small> -SR <small>Note7</small> -SA <small>Note7</small>	DC24V
		BPP (for block-off plate) <small>Note5</small>							

Notes: 3. Valve mounting location is from the left, with the solenoid on top, and the 4(A), 2(B) ports side in front.
 4. When selecting J, M, or L (base piping type) for the manifold outlet specifications, always enter -A1 (with plate) for the valve outlet type.
 5. Caution should be exercised that the block-off plate wiring is always double wiring (allocated 2 control pins at 1 stn.), regardless of the wiring connection specification. For wiring for a single solenoid, see p. 88.
 6. When the valve specification is T1 or T2, the manual override lever is placed only on the A side.
 7. Port isolators can be installed only when piping blocks are mounted on both sides. In addition, only 1 port isolator can be mounted in 1 manifold for -SA, or 1 each port isolator for -SP and -SR for a total of 2 locations. When shipping, the designated port isolators are mounted between the designated station and the station to its immediate left (the next smaller stn. No.).
 8. Cannot be mounted on the external pilot manifold.
 9. Cannot be mounted on the internal pilot manifold.
 10. Can be selected only when the manifold type is S.
 11. Can be selected only when the manifold type is SH.

F18 Series Serial Transmission Compatible Manifold Additional Parts Order Codes

Parts for manifold

F18 Z -

Parts content
GS2 : Gasket (gasket and exhaust valve)

Block-off plate (block-off plate, 2 mounting screws, and plug)

F18 BPP

Individual air supply and exhaust spacer (Spacer for plug-in type, gasket, exhaust valve, and 2 mounting screws)

F18 Z -

Specification
PP8 : Individual air supply spacer (with ϕ 8 fitting)
PP0 : Individual air supply spacer (with ϕ 10 fitting)
PR8 : Individual exhaust spacer (with ϕ 8 fitting)
PR0 : Individual exhaust spacer (with ϕ 10 fitting)

※For details, see p. 25.

Serial transmission block (single unit)

YS2

Wiring position
S : For integrated type, left-side mounting
T : For integrated type, right-side mounting

Transmission block specification

31 : For OMRON B7A Link Terminal (standard) **A1** : For OMRON CompoBus/S (16 outputs)
32 : For OMRON B7A Link Terminal (high speed) **B1** : For CC-Link (16 outputs)

YS5H1U

For CompoNet (16 outputs)
 ※DIN rail included (length 75 mm [2.95 in.])

Muffler

KM - J

Fitting size
8 : Outer diameter ϕ 8
 (for individual exhaust spacer)
10 : Outer diameter ϕ 10
 (for individual exhaust spacer)
12 : Outer diameter ϕ 12
 (Sales unit: Set of 10 mufflers)

Table for maximum number of valve units by transmission block specification

Transmission block specifications		Maximum number of units	
		Wiring connection specification	
	Max. outputs	Packed wiring (Blank)	Double wiring (-W)
-31 : For OMRON B7A Link Terminal (standard)	16	Varies depending on the number of mounted single solenoids, double solenoids, and block-off plates. The number of controlled solenoids should be designated as the maximum number of outputs or less.	8 units
-32 : For OMRON B7A Link Terminal (high speed)	16		8 units
-A1 : For OMRON CompoBus/S (16 outputs)	16		8 units
-B1 : For CC-Link (16 outputs)	16		8 units
-H1 : For CompoNet (16 outputs)	16		8 units
			8 units

Manifold Order Code Example

(8 units of F18 Series)

F18M8SL-JR-B1-W

stn.1~5 F18T0-A1-J5 DC24V
 stn.6~7 F18T2-A1-J6 DC24V
 stn.8 F18BPP-J6

Precautions for Order Codes

● Orders for valves only

Place orders from "F18 Series Single Valve Unit Order Codes" on p. 72.
 However, **Blank**, **A2** , **F3**, **F4** , **F5**, and **F6**, cannot be selected for the valve outlet type. For the wiring specification, **Blank** is the only selection.

● Wiring connection specification

Blank (packed wiring): Wiring is made in accordance with the mounted valve specifications.
-W (double wiring): Wiring is always for the double solenoid, regardless of the specifications of the mounted valve.

Caution

Caution should be exercised that the block-off plate wiring is always double wiring (allocated 2 control pins at 1 stn.), regardless of the wiring connection specification. The block-off plate wiring can be made as wiring for a single solenoid. Add **-1W** to the end of the block-off plate order code in the case. For details, consult us.

PC Board Manifold Pin Locations by Wiring Specification (Top View)

Flat cable connector (20-pin)

● **-F200** (Maximum number of control pins: 16)

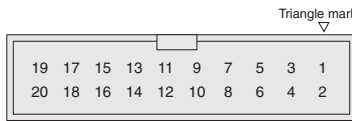

1 ~ 16 : Control pins
 17, 18 : (-) pins (Short-circuited inside)
 19, 20 : (+) pins (Short-circuited inside)

● **-F201** (Maximum number of control pins: 16)

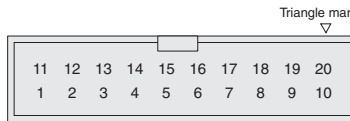

1 ~ 8 : Control pins
 11 ~ 18 : Control pins
 9, 19 : (-) pins (Short-circuited inside)
 10, 20 : (+) pins (Short-circuited inside)

Caution : Connector pin numbers are assigned for the sake of convenience.
 Use the ▽ mark as the reference.

Remark : The **-F201** corresponds to Koganei's pin locations for the PC wiring system (wire-saving unit). For details, see the Valves General Catalog.

● Various dedicated cable assemblies are available. See p. 103, 104 for details.

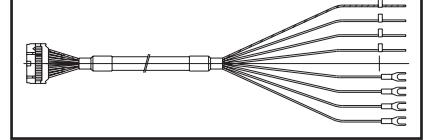

Remark: Socket and strain relief for flat cable are included at shipping.

※ For the relationship between the pin No. (terminal No.) and the corresponding solenoid, see p.91.

Detailed Diagram of Wiring System

● Positive common

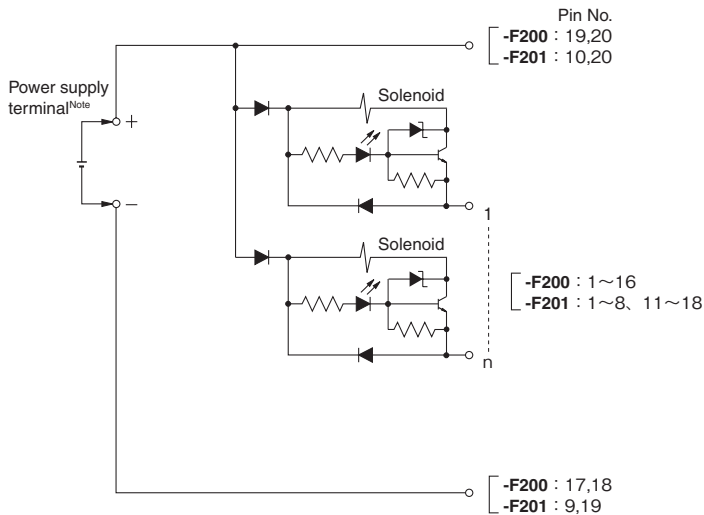

Note: For connecting a power line to the PC board manifold power terminal, see the "PC Board Manifold" precautions on p.21.

Remark: The internal circuit is of the standard type. For details of the low-current type, see p.20, 21.

Pin No. and Corresponding Solenoid (For PC Board Manifold A Type and F Type)

The examples below show the relationship between the PC board manifold pin No. and the corresponding solenoid. All the mounting examples show cases of the maximum number of control pins used.

Flat cable connector (20-pin)

● In the case of wiring specification **-F200** (Maximum number of control pins: 16)

Example 1

**F10M16APJ-F200-S stn.1 ~ 15 F10T1-A1-PP DC24V
stn.16 F10BPC**

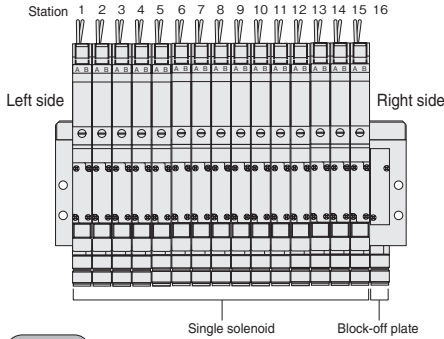

Number of units : 16 units
Wiring specification : **-F200**
Wiring connection specification : **-S (single wiring)**

(Top View)

Triangle mark
▽



Pin No.	19	17	15	13	11	9	7	5	3	1
Valve No.	+	-	15A	13A	11A	9A	7A	5A	3A	1A
Pin No.	20	18	16	14	12	10	8	6	4	2
Valve No.	+	-	16A	14A	12A	10A	8A	6A	4A	2A

Example 2

**F10M8APJ-F200-W stn.1 ~ 4 F10T1-A1-PP DC24V
stn.5 ~ 7 F10T2-A1-PP DC24V
stn.8 F10BPC**

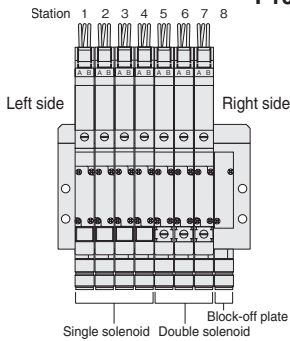

Number of units : 8 units
Wiring specification : **-F200**
Wiring connection specification : **-W (double wiring)**

(Top View)

Triangle mark
▽

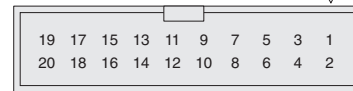

Pin No.	19	17	15	13	11	9	7	5	3	1
Valve No.	+	-	8A	7A	6A	5A	4A	3A	2A	1A
Pin No.	20	18	16	14	12	10	8	6	4	2
Valve No.	+	-	8B	7B	6B	5B	4B	3B	2B	1B

Flat cable connector (20-pin)

● In the case of wiring specification **-F201** (Maximum number of control pins: 16)

Example 1

**F10M16APJ-F201-S stn.1 ~ 15 F10T1-A1-PP DC24V
stn.16 F10BPC**

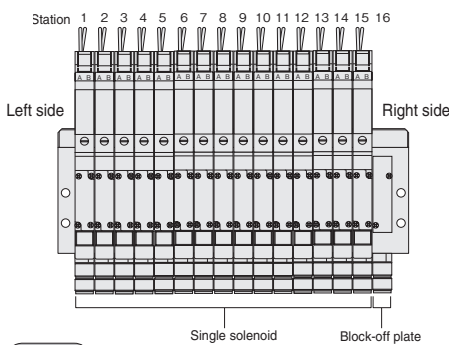

Number of units : 16 units
Wiring specification : **-F201**
Wiring connection specification : **-S (single wiring)**

(Top View)

Triangle mark
▽

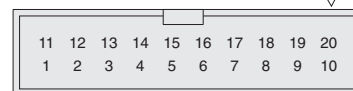

Pin No.	11	12	13	14	15	16	17	18	19	20
Valve No.	9A	10A	11A	12A	13A	14A	15A	16A	-	+
Pin No.	1	2	3	4	5	6	7	8	9	10
Valve No.	1A	2A	3A	4A	5A	6A	7A	8A	-	+

Example 2

**F10M8APJ-F201-W stn.1~4 F10T1-A1-PP DC24V
stn.5~7 F10T2-A1-PP DC24V
stn.8 F10BPC**

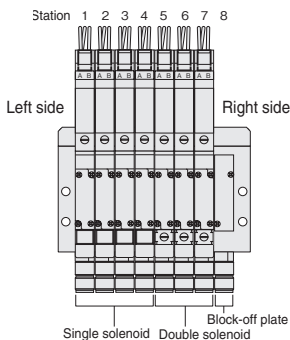

Number of units : 8 units
Wiring specification : **-F201**
Wiring connection specification : **-W (double wiring)**

(Top View)

Triangle mark
▽



Pin No.	11	12	13	14	15	16	17	18	19	20
Valve No.	5A	5B	6A	6B	7A	7B	8A	8B	-	+
Pin No.	1	2	3	4	5	6	7	8	9	10
Valve No.	1A	1B	2A	2B	3A	3B	4A	4B	-	+

Caution: Connector pin numbers are assigned for the sake of convenience. Use the ▽ mark as the reference.

Notes: 1. The valve No.1A, 1B, 2A, 2B... numerals show the stn. numbers in order, while the letters A and B show the A and B sides of the solenoid.
2. The stn. numbers are counted from the left, 1, 2..., with the solenoid on top and the valve in front.

Pin (Terminal) Locations by Wiring Specification (Top View) (For Monoblock Manifold A Type and F Type Wire-Saving Type, Split Manifold Plug-in Type)

Flat cable connector (10-pin)

●-F100□□ (Maximum number of control pins: 8)

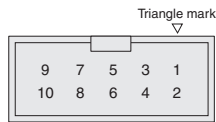

1~8 : Control pins
9, 10 : Common pins (short-circuited within the wiring block)

●-F101□□ (Maximum number of control pins: 8)



1~8 : Control pins
9 : (-) pin ^{Note}
10 : (+) pin

Note: For no-power terminal type, set to NC (unused pin).

Flat cable connector (20-pin)

●-F200□□ (Maximum number of control pins: 16)

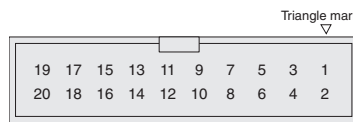

1~16 : Control pins
17, 18 : (-) pins (short-circuited within the wiring block)^{Note}
19, 20 : (+) pins (short-circuited within the wiring block)
Note: For no-power terminal type, set to NC (unused pin).

●-F201□□ (Maximum number of control pins: 16)

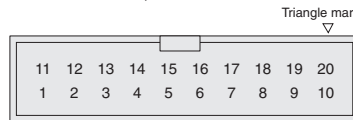

1~8 : Control pins
11~18 : Control pins
9, 19 : (-) pins (short-circuited within the wiring block)^{Note}
10, 20 : (+) pins (short-circuited within the wiring block)

Note: For no-power terminal type, set to NC (unused pin).

Caution: Connector pin numbers are assigned for the sake of convenience.
Use the ▽ mark as the reference.

Remark : The -F201 corresponds to Koganei's pin locations for the PC wiring system (wire-saving unit). For details, see the Valves General Catalog.

D-sub connector (25-pin)

●-D250□□ (Maximum number of control pins: 16)



1~16 : Control pins
20, 21, 22 : (-) pins (short-circuited within the wiring block)^{Note}
23, 24, 25 : (+) pins (short-circuited within the wiring block)
Note: For no-power terminal type, set to NC (unused pin).

Caution: The above pin numbers are assigned based on the solenoid valve wiring sequence for the sake of convenience. They differ from the pin locations and pin numbers (marking) prescribed (JIS-X5101) for the Data Circuit-terminating Equipment (DCE).

●-D251□□ Pin locations based on JIS (Maximum number of control pins: 20)



1~10, 14~23 : Control pins
12, 13 : (-) pins (short-circuited within the wiring block)^{Note}
24, 25 : (+) pins (short-circuited within the wiring block)
Note: For no-power terminal type, set to NC (unused pin).

Flat cable connector (26-pin)

●-F260□□ (Maximum number of control pins: 20)

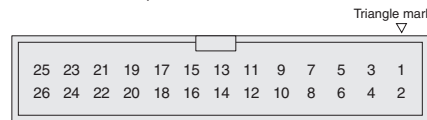

1~20 : Control pins
23, 24 : (-) pins (short-circuited within the wiring block)^{Note}
25, 26 : (+) pins (short-circuited within the wiring block)
Note: For no-power terminal type, set to NC (unused pin).

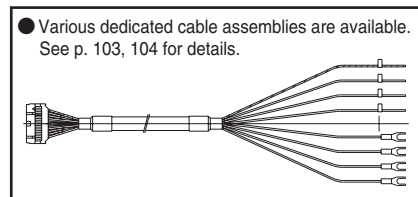

D-sub connector (37-pin)

●-D370NU (Maximum number of control pins: 32)

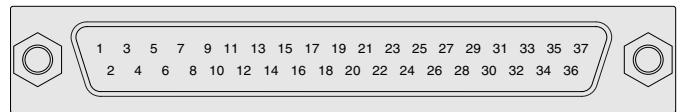

1~32 : Control pin
36, 37 : Common pin (For positive common)

Caution: The above pin numbers are assigned based on the solenoid valve wiring sequence for the sake of convenience. They differ from the pin locations and pin numbers (marking) prescribed (JIS-X5103) for the Data Circuit-terminating Equipment (DCE).

Terminal block type (19 terminals, M3 screws)

●-T200 (Maximum number of control pins: 18)



1~18 : Control terminals
COM : Common terminal

Caution: Apply the tightening torque for the terminal screw (M3) to 49.0 N·cm [4.3 in·lbf] or less.

※ For the relationship between the pin No.(terminal No.) and the corresponding solenoid, see p. 97- 102.

F18 SERIES Specifications

Specifications

Basic Models and Valve Functions

Item	Basic model	F18T0	F18T1 F18T2	F18T3 F18T4 F18T5
	Number of positions	2 positions		
Number of ports	5			
Valve function	Single solenoid only	Both single and double solenoid use		Closed center, Exhaust center, Pressure center

Remark: For the optional specifications and order codes, see p.72-88.

Specifications

Item	Basic model	F18T0 F18T1 F18T2	F18T3 F18T4 F18T5	F18T0G F18T1G F18T2G	F18T3G F18T4G F18T5G	F18T0V F18T1V F18T2V	F18T3V	
	Media	Air						
Operation type	Internal pilot type		External pilot type (for positive pressure)		External pilot type (for vacuum)			
Flow rate characteristics	Sonic conductance $C \text{ dm}^3/(\text{s} \cdot \text{bar})$ ^{Note1}	3.6						
	Effective area ^{Note2} mm^2 (Cv)	18 [1]						
Port size ^{Note3}	Dual use fitting for $\phi 8$ and $\phi 10$, Rc1/4, NPT1/4		M5×0.8, 10-32UNF, dual use fitting for $\phi 8$ and $\phi 10$, Rc1/4, NPT1/4					
Lubrication	Not required							
Operating pressure range	Main valve	0.15~0.7 MPa [22~102 psi.]		0~0.7 MPa [0~102 psi.] ^{Note4}		-100 kPa~0.15 MPa [-29.53 in.Hg~22 psi.]		
	External pilot	—		0.2~0.7 MPa [29~102 psi.] ^{Note4}		0.2~0.7 MPa [29~102 psi.]		
Proof pressure	MPa [psi.]		1.05 [152]					
Response time ^{Note5}	12VDC, 24VDC	25/35 or below	15/70 or below	25/35 or below	15/70 or below	25/35 or below	15/70 or below	
ON/OFF	ms	100VAC	25/35 or below	15/70 or below	25/35 or below	15/70 or below	25/35 or below	
Maximum operating frequency	Hz		5					
Minimum time to energize for self holding ^{Note6}	ms		50	—	50	—	50	—
Operating temperature range (atmosphere and media)	°C [°F]		5~50 [41~122]					
Shock resistance	m/s^2 [G]		1373 [140] (Axial direction 294.2 [30])	294.2 [30]	1373 [140] (Axial direction 294.2 [30])	294.2 [30]	1373 [140] (Axial direction 294.2 [30])	294.2 [30]
Mounting direction	Any							

- Notes: 1. The sonic conductance value is a calculated value, and not a measured value.
 2. For details, see the effective area on p.174.
 3. For details, see the port size on p.174.
 4. When the main valve pressure is 0.2~0.7 MPa [29~102 psi.], set the external pilot pressure to the main valve pressure or higher, and to 0.7 MPa [102 psi.] or less.

- Notes: 5. Values when air pressure is 0.5 MPa [73 psi.]. For switching phase timing in the AC specification, add a maximum of 5 ms to the response time. The values for 2-position valves are those when used as a single solenoid, and the values for 3-position valves are those when switching from the neutral position of closed center.
 6. When used as a double solenoid valve. Excludes **T0**.

Remark: Specification values are based on Koganei test standards.

Solenoid Specifications

Item	Rated voltage	12VDC	24VDC	100VAC	120VAC		
	Voltage range	V	10.8~13.2 (12±10%)	21.6~26.4 (24±10%)	90~110 (100±10%)	108~132 (120±10%)	
Rated frequency	Hz	—	—	50	60		
Current (when rated voltage is applied)	mA (r.m.s)	Starting	—	10 ^{Note 1}	10 ^{Note 1}	11.8	11.8
		Holding	76	38	10 ^{Note 1}	10 ^{Note 1}	11.8
Power consumption	W	0.9	0.9	1.0 VA	1.4 VA		
Allowable leakage current	mA	4.0	2.0	2.0	2.0		
Type of insulation	Type B						
Insulation resistance ^{Note 2}	MΩ	Over 100					
Color of LED indicator ^{Note3}	14(SA) : Red, 12(SB) : Green		14(SA) : Red, 12(SB) : Green	14(SA) : Red, 12(SB) : Green			
Surge suppression (as standard)	Flywheel diode			Bridge diode			

- Notes: 1. Since the AC types have built-in bridge diodes, the starting current and holding current values are virtually the same.
 2. Value at 500VDC megger.
 3. The color of the **T0** indicator is red only.

Remark: Specification values are based on Koganei test standards.

Specifications for DIN Connector (-39□) Type

Basic Models and Valve Functions

Item	Basic model	F18T0	F18T2	F18T3 F18T4 F18T5
	Number of positions	2 positions		3 positions
Number of ports	5			
Valve function	Single solenoid only	Double solenoid only		Closed center, Exhaust center, Pressure center

Remark: For the optional specifications and order codes, see p.72-88.

Specifications

Item	Basic model	F18T0 F18T2	F18T3 F18T4 F18T5	F18T0G F18T2G	F18T3G F18T4G F18T5G	F18T0V F18T2V	F18T3V
	Media	Air					
Operation type	Internal pilot type		External pilot type (for positive pressure)		External pilot type (for vacuum)		
Flow rate characteristics	Sonic conductance $C \text{ dm}^3/(\text{s} \cdot \text{bar})$ ^{Note1}	3.6					
	Effective area ^{Note2} mm^2 (Cv)	18 [1]					
Port size ^{Note3}	Dual use fitting for $\phi 8$ and $\phi 10$, Rc1/4, NPT1/4		M5×0.8, 10-32UNF, dual use fitting for $\phi 8$ and $\phi 10$, Rc1/4, NPT1/4				
Lubrication	Not required						
Operating pressure range	Main valve	0.15~0.7 MPa [22~102 psi.]		0~0.7 MPa [0~102 psi.] ^{Note4}		-100 kPa~0.15 MPa [-29.53 in.Hg~22 psi.]	
	External pilot	—		0.2~0.7 MPa [29~102 psi.] ^{Note4}		0.2~0.7 MPa [29~102 psi.]	
Proof pressure	MPa [psi.] 1.05 [152]						
Response time ^{Note5} ON/OFF	ms	25/35 or below	15/70 or below	25/35 or below	15/70 or below	25/35 or below	15/70 or below
Maximum operating frequency	Hz	5					
Minimum time to energize for self holding ^{Note6}	ms	50	—	50	—	50	—
Operating temperature range (atmosphere and media)	°C [°F]	5~50 [41~122]					
Shock resistance	m/s^2 [G]	1373 [140] (Axial direction 294.2 [30])	294.2 [30]	1373 [140] (Axial direction 294.2 [30])	294.2 [30]	1373 [140] (Axial direction 294.2 [30])	294.2 [30]
Mounting direction	Any						

Notes: 1. The sonic conductance value is a calculated value, and not a measured value.
 2. For details, see the effective area on p.174.
 3. For details, see the port size on p.174.
 4. When the main valve pressure is 0.2~0.7 MPa [29~102 psi.], set the external pilot pressure to the main valve pressure or higher, and to 0.7 MPa [102 psi.] or less.

Notes: 5. Values when air pressure is 0.5 MPa [73 psi.]. For switching phase timing in the AC specification, add a maximum of 5 ms to the response time. The values for 2-position valves are those when used as a single solenoid, and the values for 3-position valves are those when switching from the neutral position of closed center.
 6. In the case of a double solenoid valve.

Remark: Specification values are based on Koganei test standards.

Solenoid Specifications for DIN Connector (-39□) Type

Item	Rated voltage	12VDC	24VDC	120VAC		240VAC		
	Voltage range	V	10.8~13.2 (12±10%)	21.6~26.4 (24±10%)	90~132		180~264	
Current	Frequency	Hz	—	—	50	60	50	60
	Starting	mA (r.m.s)	—	—	43	38	22	19
	Holding	mA (r.m.s)	140 (1.7W)	75 (1.8W)	29	24	14	12
Allowable leakage current	mA	8	4	4		2		
Insulation resistance ^{Note}	MΩ	Over 100						
Surge suppression (as standard)		Surge absorption transistor		Varistor		Varistor		

Note: Value at 500VDC megger.

Remark: Specification values are based on Koganei test standards.

Cylinder Operating Speed

Flow Rate

How to obtain cylinder speed

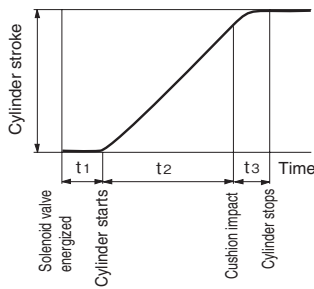

Measuring conditions

- Air pressure : 0.5 MPa [73 psi.]
- Piping (outer diameter×inner diameter×length) : φ10×φ7.5×1000 mm [39 in.]
- Fitting : Quick fitting TS10-02
- Load ratio = $\frac{\text{Load}}{\text{Cylinder theoretical thrust}}$ (%)
- Cylinder stroke : 150 mm [5.91 in.]

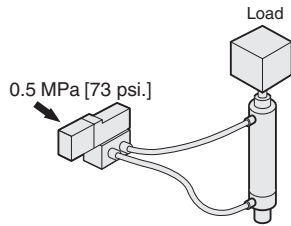

Maximum operating speed

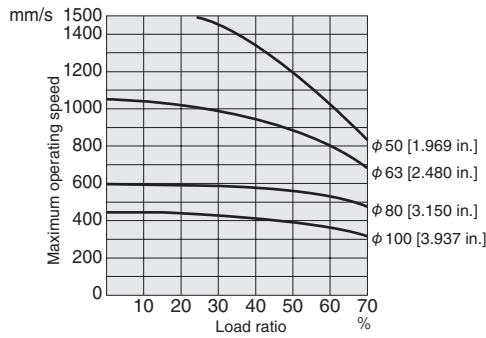

Delay time

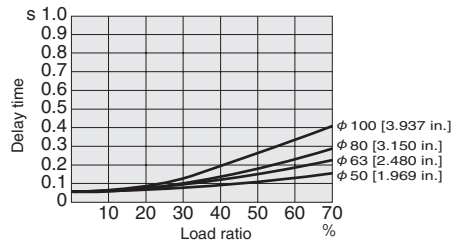

Note: Delay time may vary according to the cylinder stroke.

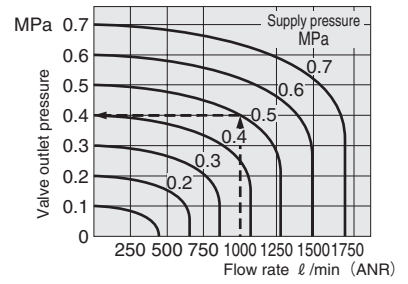

How to read the graph

When the supply pressure is 0.5 MPa [73 psi.] and flow rate is 1000 l/min [35.3 ft³/min.] (ANR), the valve outlet pressure becomes 0.4 MPa [58 psi.].

- 1 mm/s = 0.0394 in./sec.
- 1 MPa = 145 psi.
- 1 l/min = 0.0353ft³/min.

Port Size

Description/Piping specification		PR	X (P2)	4 (A), 2 (B)	1 (P), 3 (R2), 5 (R1), 3, 5 (R)
With sub-base		M5×0.8, 10-32UNF	M5×0.8, 10-32UNF	Rc1/4, NPT1/4	Rc1/4, NPT1/4
Single unit	With female thread block	—	—	Rc1/4, NPT1/4	Rc1/4, NPT1/4
	With dual use fitting block	—	—	Dual use fitting for φ8 and φ10	Rc1/4, NPT1/4
	With single use fitting block	—	—	φ8 or φ10	Rc1/4, NPT1/4
Manifold	Monoblock type with female thread block	M5×0.8, 10-32UNF	M5×0.8, 10-32UNF	Rc1/4, NPT1/4	Rc3/8, NPT3/8
	Monoblock type with fitting block	M5×0.8, 10-32UNF	M5×0.8, 10-32UNF	Dual use fitting for φ8 and φ10	Rc3/8, NPT3/8
	Monoblock type with single use fitting block	M5×0.8, 10-32UNF	M5×0.8, 10-32UNF	φ8 or φ10	Rc3/8, NPT3/8
	Split type with female thread block, and serial transmission type with female thread block	—	M5×0.8, 10-32UNF	Rc1/4, NPT1/4	Rc3/8, NPT3/8 Single use fitting for φ12
	Split type with fitting block, and serial transmission type with fitting block	—	M5×0.8, 10-32UNF	Dual use fitting for φ8 and φ10	
	Split type with single use fitting block, and serial transmission type with single use fitting block	—	M5×0.8, 10-32UNF	φ8 or φ10	

Effective Area [Cv]

When used as a single unit

Basic model	Effective area mm ² [Cv]	Basic model	Effective area mm ² [Cv]
F18T0□-A2	17.3 [0.96]	F18T0□-F5	15.0 [0.83]
F18T1□-A2			
F18T2□-A2			
F18T3□-A2			
F18T4□-A2			
F18T5□-A2			
F18T0□-F3	17.0 [0.94]	F18T0□-F6	16.5 [0.91]
F18T1□-F3			
F18T2□-F3			
F18T3□-F3			
F18T4□-F3			
F18T5□-F3			
F18T0□-F4	17.3 [0.96]	F18T0□-F6	16.5 [0.91]
F18T1□-F4			
F18T2□-F4			
F18T3□-F4			
F18T4□-F4			
F18T5□-F4			

When mounted on a manifold

Manifold model		mm ² [Cv]		
Valve type		F18M□F	F18M□A	F18M□N(P)(S)
F18T0□ F18T1□ F18T2□	Outlet port	17.0 [0.94]	16.0 [0.89]	18.0 [1]
	Dual use fitting for φ8 and φ10, Female thread			
F18T3□ F18T4□ F18T5□	Outlet port φ8 fitting	15.0 [0.83]	14.7 [0.82]	16.7 [0.93]
	Outlet port φ10 fitting	16.5 [0.91]	15.0 [0.83]	17.0 [0.94]

Caution: When the individual air supply spacer or the individual air exhaust spacer is used, effective area decreases by about 30%.

Remark: Specification values are based on Koganei test standards.

Mass

Single Valve Unit Mass

g [oz.]

F18T□□	F18T□□-A1	F18T□□-A2	F18T□□-FJ	F18T□□-FJ5	F18T□□-FJ6
Outlet portion None	Outlet portion With plate	Outlet portion With plate	Outlet portion With dual use fitting block	Outlet portion With φ 8 fitting block	Outlet portion With φ 10 fitting block
Inlet portion None	Inlet portion None	Inlet portion With A type sub-base	Inlet portion None	Inlet portion None	Inlet portion None
118 [4.16]	144 [5.08]	308 [10.86]	159 [5.61]	184 [6.49]	193 [6.81]

g [oz.]

F18T□□-FM	F18T□□-F3	F18T□□-F4	F18T□□-F5	F18T□□-F6
Outlet portion With female thread block	Outlet portion With dual use fitting block	Outlet portion With female thread block	Outlet portion With φ 8 fitting block	Outlet portion With φ 10 fitting block
Inlet portion None	Inlet portion With female thread block	Inlet portion With female thread block	Inlet portion With female thread block	Inlet portion With female thread block
147 [5.19]	184 [6.49]	172 [6.07]	209 [7.37]	218 [7.69]

Basic Type **F18T0** is 15 g [0.53 oz.] less than the mass shown above.

Monoblock Manifold Mass (single valve unit included)

g [oz.]

Monoblock manifold	Mass calculation of each unit			
	4(A), 2(B) ports outlet specifications			
	Female thread block	Dual use fitting block	φ 8 fitting block	φ 10 fitting block
A type	$(334 \times n) + 165 [(11.78 \times n) + 5.82]$	$(344 \times n) + 165 [(12.13 \times n) + 5.82]$	$(369 \times n) + 165 [(13.02 \times n) + 5.82]$	$(378 \times n) + 165 [(13.33 \times n) + 5.82]$
F type	$(222 \times n) + 70 [(7.83 \times n) + 2.47]$	$(232 \times n) + 70 [(8.18 \times n) + 2.47]$	$(257 \times n) + 70 [(9.07 \times n) + 2.47]$	$(266 \times n) + 70 [(9.38 \times n) + 2.47]$

Calculation example : **F18M8AM**

stn.1~stn.8 **F18T1-A1-PS DC24V**

$(334 \times 8) + 165 = 2837$ g [100.07 oz.]

When mounting a block-off plate, subtract 110 g [3.88 oz.] per unit from the above calculation result for the female thread specification; subtract 120 g [4.23 oz.] for the dual use fitting specification; subtract 145 g [5.11 oz.] for the φ 8 fitting specification; and subtract 154 g [5.43 oz.] for the φ 10 fitting specification.

When mounting the **F18T0** specification valve, subtract 15 g [0.53 oz.] per unit from the above calculation result.

Mass of Split Manifold and Serial Transmission Compatible Manifold

Because the valve and manifold have the same output specifications, their mass is the same. The mass can only be changed by choosing a different type of inlet/outlet block.

Mass of Split Manifold Non-Plug-in Type (single valve unit included)

g [oz.]

Non-plug-in type	Mass calculation of each unit			
	4(A), 2(B) ports outlet specifications			
	Female thread block	Dual use fitting block	φ 8 fitting block	φ 10 fitting block
	$(241 \times n) + 234 [(8.50 \times n) + 8.25]$	$(251 \times n) + 234 [(8.85 \times n) + 8.25]$	$(276 \times n) + 234 [(9.74 \times n) + 8.25]$	$(285 \times n) + 234 [(10.05 \times n) + 8.25]$

g [oz.]

Additional mass	
Piping block specification	
Female thread block	Fitting block
164 [5.78]	189 [6.67]

Calculation example : **F18M8N-MR**

stn.1~stn.8 **F18T1-A1-PS DC24V**

$(241 \times 8) + 234 + 164 = 2326$ g [82.05 oz.]

When mounting a block-off plate, subtract 110 g [3.88 oz.] per unit from the above calculation result for the female thread specification; subtract 120 g [4.23 oz.] for the dual use fitting specification; subtract 145 g [5.11 oz.] for the φ 8 fitting specification; and subtract 154 g [5.43 oz.] for the φ 10 fitting specification.

When mounting the **F18T0** specification valve, subtract 15 g [0.53 oz.] per unit from the above calculation result.

Mass

Mass of Split Manifold Plug-in Type/ Serial Transmission Compatible Manifold (single valve unit included) g [oz.]

Plug-in type Serial transmission compatible manifold	Mass calculation of each unit			
	4(A), 2(B) ports outlet specifications			
	Female thread block	Dual use fitting block	φ 8 fitting block	φ 10 fitting block
	$(243 \times n) + 238 \quad [(8.57 \times n) + 8.40]$	$(253 \times n) + 238 \quad [(8.92 \times n) + 8.40]$	$(278 \times n) + 238 \quad [(9.81 \times n) + 8.40]$	$(287 \times n) + 238 \quad [(10.12 \times n) + 8.40]$

g [oz.]

Additional mass	
Piping block specification	
Female thread block	Fitting block
174 [6.14]	199 [7.02]

g [oz.]

Additional mass				
Wiring block specification				
-F100, -F101	-F200, -F201, -F260	-D250, -D251	-D370NU	-T200
69 [2.43]	71 [2.50]	72 [2.54]	96 [3.39]	154 [5.43]

g [oz.]

Additional mass	
Serial transmission block	
160 [5.64]	(236 [8.32] for CompoNet)

Calculation example : **F18M8PM-MR-F201 DC24V**

stn.1~stn.8 F18T1-A1 DC24V

$(243 \times 8) + 238 + 174 + 71 = 2427$ g [85.61 oz.]

When mounting the block-off plate, subtract 130 g [4.59 oz.] per unit from the above calculation result.

When mounting the **F18□T0** specification valve, subtract 15 g [0.53 oz.] per unit from the above calculation result.

F18T Valve specifications **-F3-PS**

With outlet port dual use fitting block
 With inlet port female thread block
 S type plug connector

* For T0 Type dimensions, see page 178.

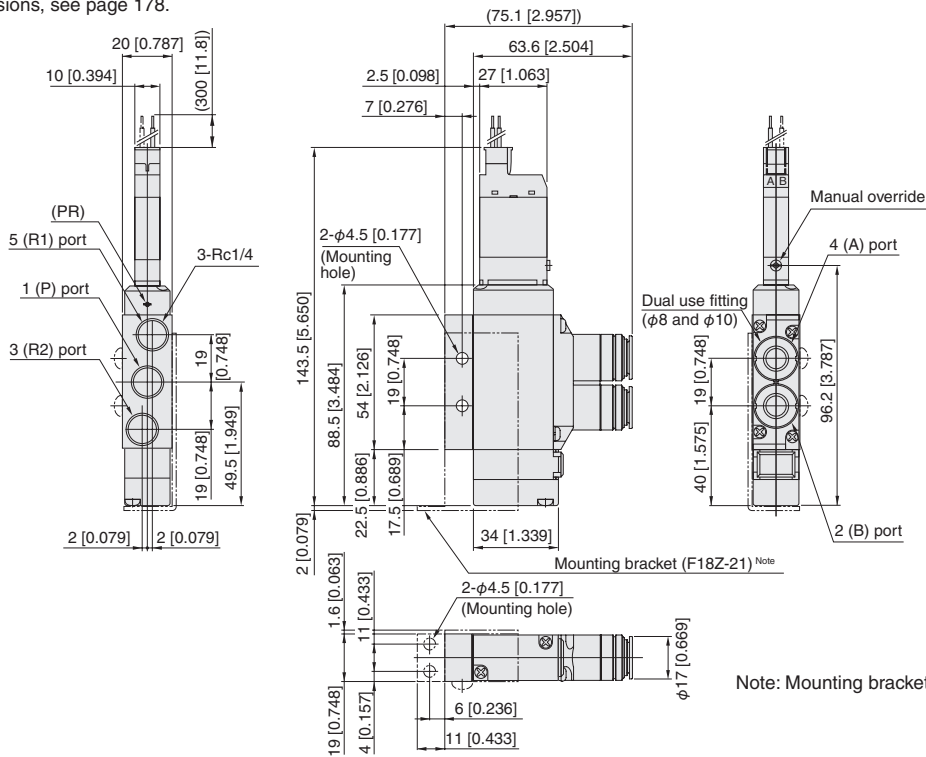

Note: Mounting brackets are additional parts (options).

F18T Valve specifications **-F4-PS**

F18T Valve specifications **-F4H-PS**

With outlet port female thread block
 With inlet port female thread block
 S type plug connector

* For T0 Type dimensions, see page 178.

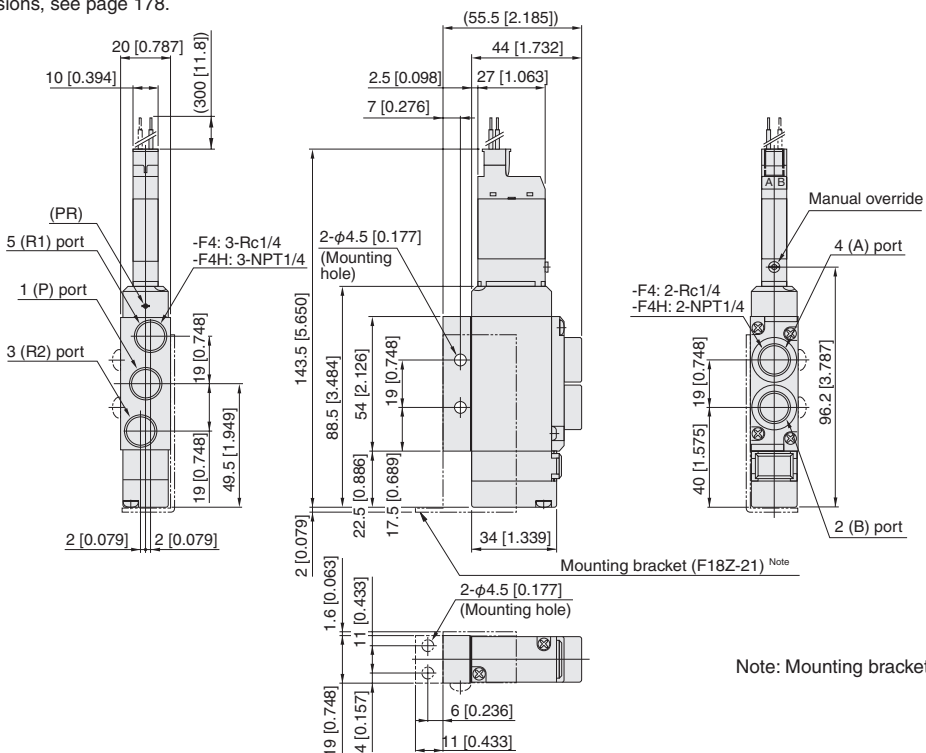

Note: Mounting brackets are additional parts (options).

F18 SERIES

F18T0-F □ -PS

With outlet port single use fitting block
 With inlet port female thread block
 S type plug connector

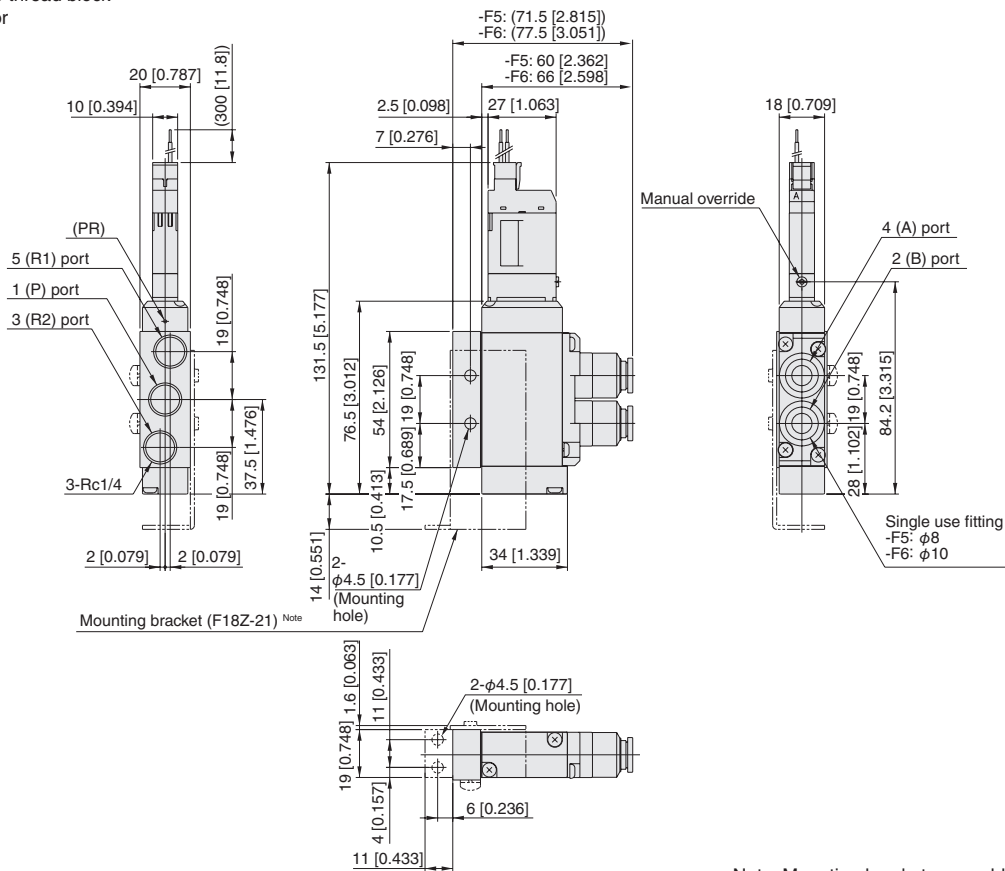

Note: Mounting brackets are additional parts (options).

Dimensions of F18 series single valve unit mm [in]



F18T Valve specifications Operation system **-A2-PS**

F18T Valve specifications Operation system **-A2H-PS**

With A-type sub-base
S type plug connector

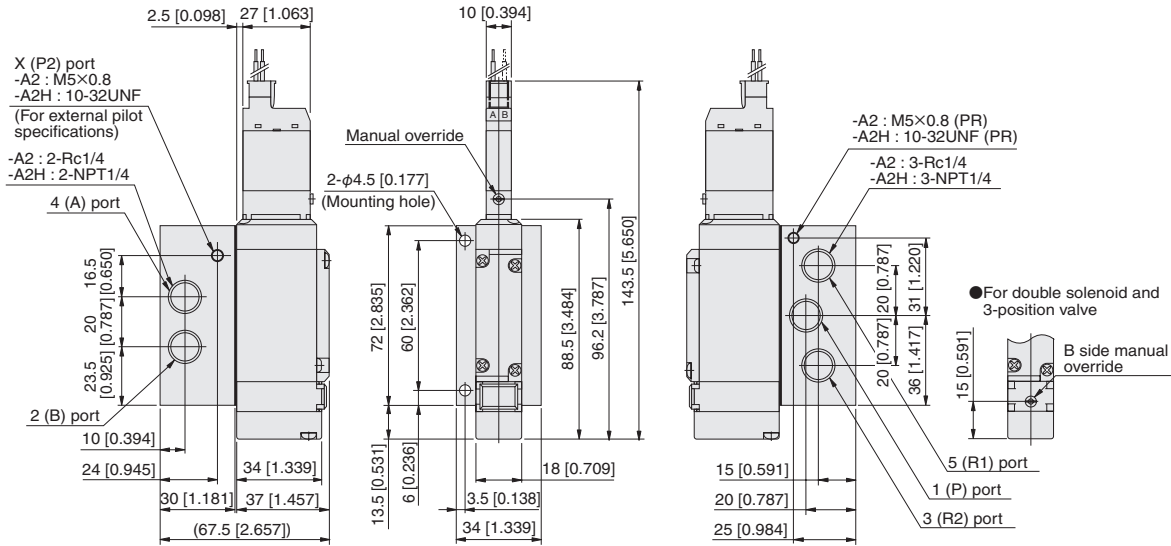

Note: The overall valve length of the T0 type is 12 mm [0.472 in] shorter (end cover side protrusion is 12 mm [0.472 in] less).

Options

● L type plug connector: **-PL**

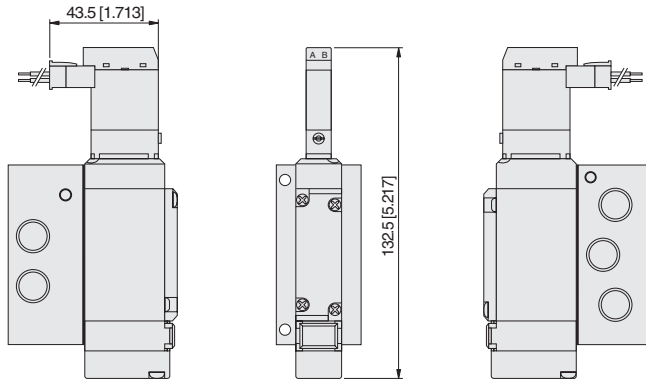

Note: The overall valve length of the T0 type is 12 mm [0.472 in] shorter (end cover side protrusion is 12 mm [0.472 in] less).

● Manual lever: **-R**

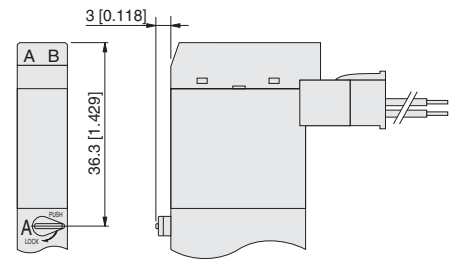

● Solenoid with DIN type connector: **-39**

Pg. 7 Compatible cable diameter φ4 to φ6

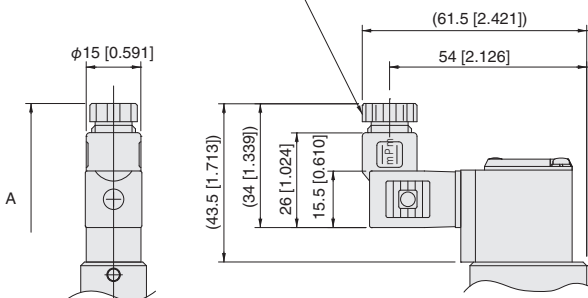

Model	Symbol	A (Full length)
F18T0		127.7 [5.028]
F18T2		180.4 [7.102]
F18T2 to T5		192.4 [7.575]

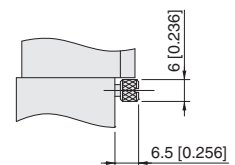

● Protruding locking type manual override: **-83**

Dimensions of F18 series monoblock manifold A type mm [in]

F18M Number of valves A M Pilot specifications (Base piping type)



Monoblock manifold A type
With manifold outlet port dual use fitting block
S type plug connector

Internal pilot specifications

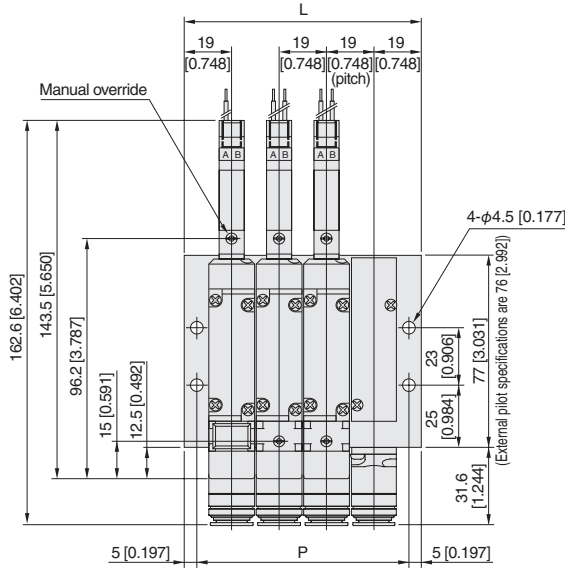
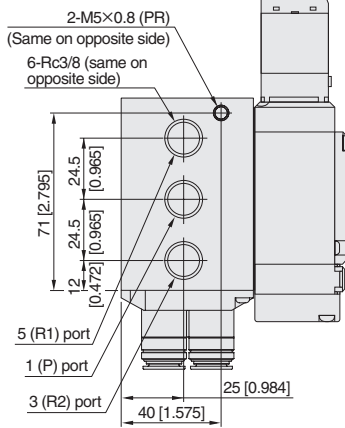

External pilot specifications

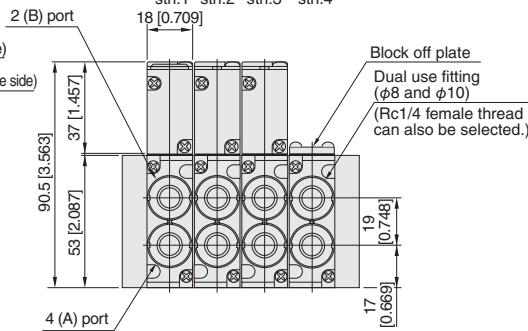
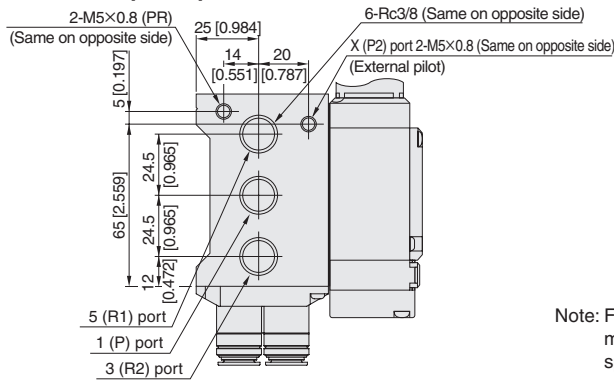

Note: For external pilot specifications, the shape of the monoblock manifold A type body is different from the internal pilot specifications.

Unit dimensions

Number of units	L	P
2	57 [2.244]	47 [1.850]
3	76 [2.992]	66 [2.598]
4	95 [3.740]	85 [3.346]
5	114 [4.488]	104 [4.094]
6	133 [5.236]	123 [4.843]
7	152 [5.984]	142 [5.591]
8	171 [6.732]	161 [6.339]
9	190 [7.480]	180 [7.087]
10	209 [8.228]	199 [7.835]
11	228 [8.976]	218 [8.583]
12	247 [9.724]	237 [9.331]
13	266 [10.472]	256 [10.079]
14	285 [11.220]	275 [10.827]
15	304 [11.969]	294 [11.575]
16	323 [12.717]	313 [12.323]
17	342 [13.465]	332 [13.071]
18	361 [14.213]	351 [13.819]
19	380 [14.961]	370 [14.567]
20	399 [15.709]	389 [15.315]

F18M Number of valves AL Pilot specifications (Base piping type)

Monoblock manifold A type
With manifold outlet port single use fitting block
S type plug connector

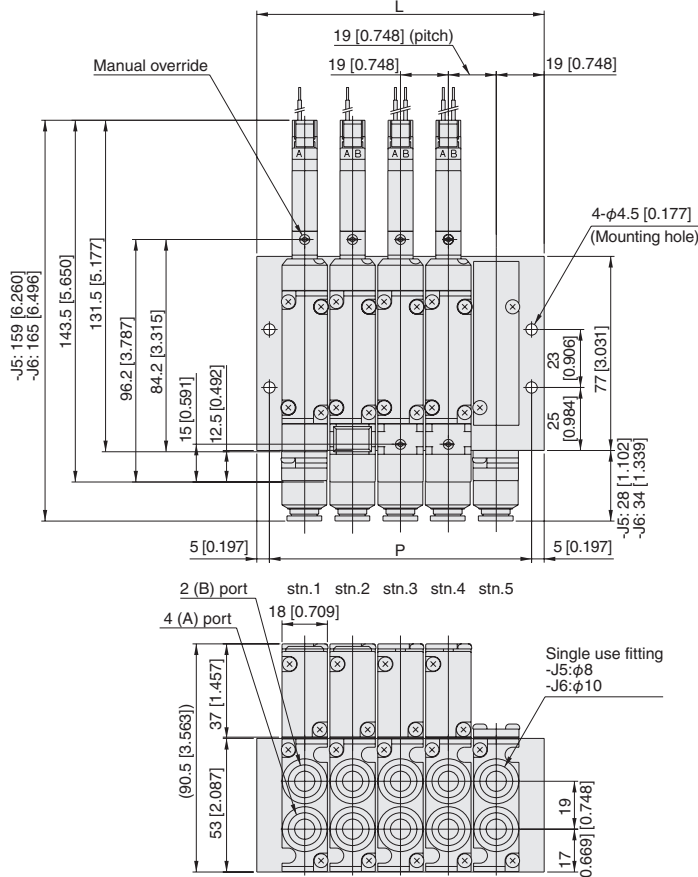
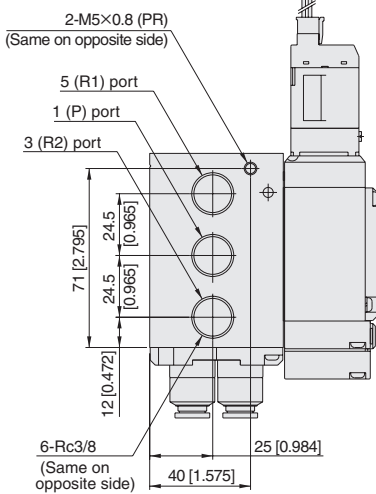

Unit dimensions

Number of units	L	P
2	57 [2.244]	47 [1.850]
3	76 [2.992]	66 [2.598]
4	95 [3.740]	85 [3.346]
5	114 [4.488]	104 [4.094]
6	133 [5.236]	123 [4.843]
7	152 [5.984]	142 [5.591]
8	171 [6.732]	161 [6.339]
9	190 [7.480]	180 [7.087]
10	209 [8.228]	199 [7.835]
11	228 [8.976]	218 [8.583]
12	247 [9.724]	237 [9.331]
13	266 [10.472]	256 [10.079]
14	285 [11.220]	275 [10.827]
15	304 [11.969]	294 [11.575]
16	323 [12.717]	313 [12.323]
17	342 [13.465]	332 [13.071]
18	361 [14.213]	351 [13.819]
19	380 [14.961]	370 [14.567]
20	399 [15.709]	389 [15.315]

Dimensions of F18 series monoblock manifold F type mm [in]



F18M Number of valves F (Direct piping type)

Monoblock manifold F type
With valve outlet port dual use fitting block
S type plug connector

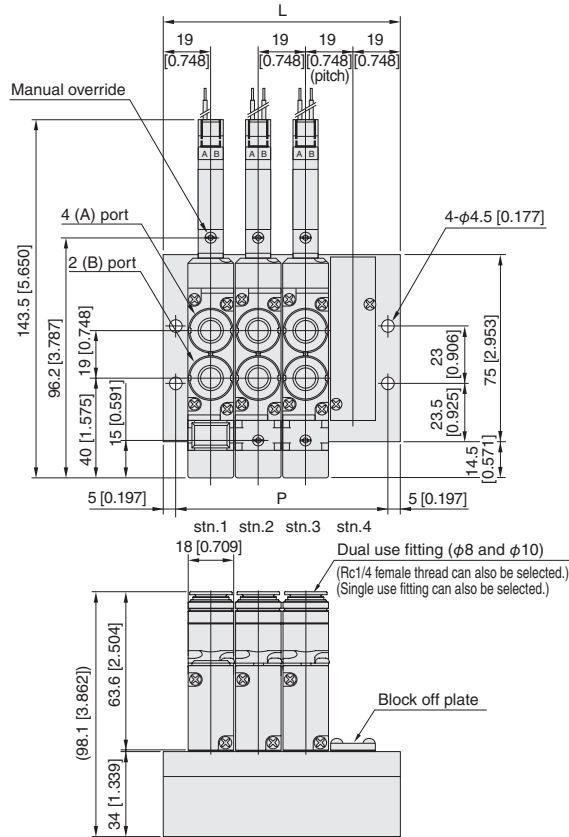
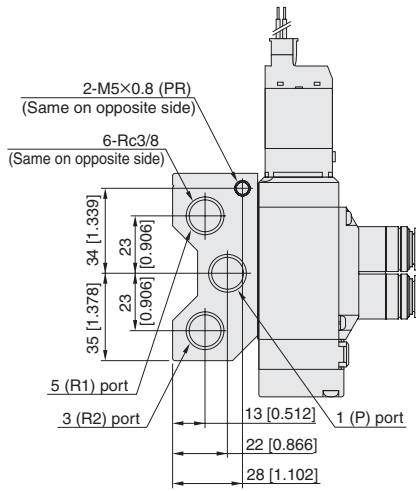

Note: The overall valve length of the T0 type is 12 mm [0.472 in] shorter (end cover side protrusion is 12 mm [0.472 in] less).

Unit dimensions

Number of units	L	P
2	57 [2.244]	47 [1.850]
3	76 [2.992]	66 [2.598]
4	95 [3.740]	85 [3.346]
5	114 [4.488]	104 [4.094]
6	133 [5.236]	123 [4.843]
7	152 [5.984]	142 [5.591]
8	171 [6.732]	161 [6.339]
9	190 [7.480]	180 [7.087]
10	209 [8.228]	199 [7.835]
11	228 [8.976]	218 [8.583]
12	247 [9.724]	237 [9.331]
13	266 [10.472]	256 [10.079]
14	285 [11.220]	275 [10.827]
15	304 [11.969]	294 [11.575]
16	323 [12.717]	313 [12.323]
17	342 [13.465]	332 [13.071]
18	361 [14.213]	351 [13.819]
19	380 [14.961]	370 [14.567]
20	399 [15.709]	389 [15.315]

F18M Number of valves FH (Direct piping type)

Monoblock manifold F type
With valve outlet port female thread block
S type plug connector

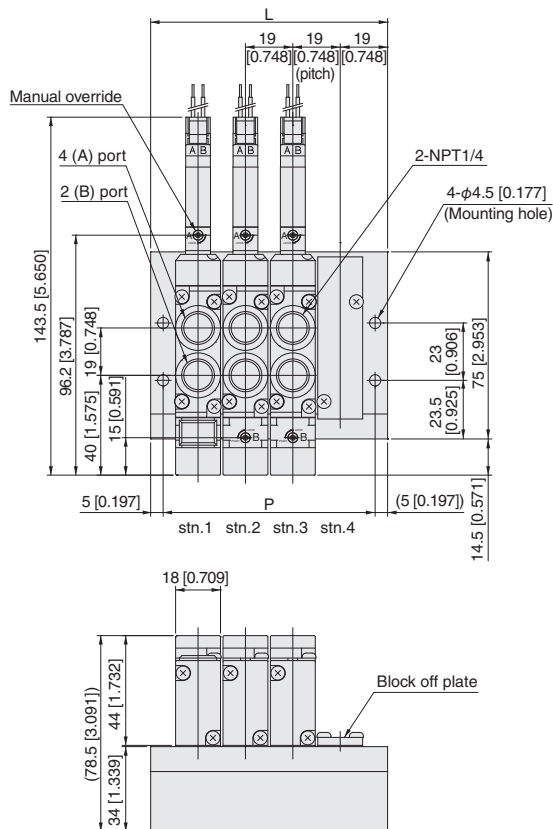
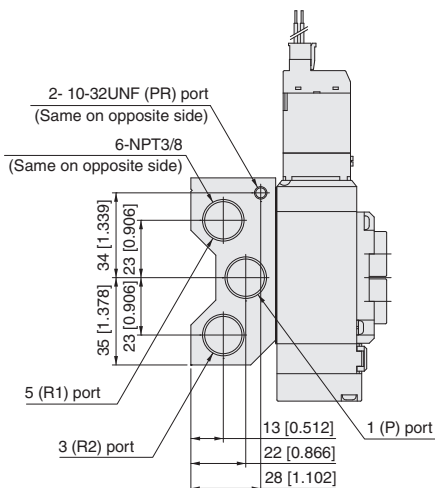

Note: The overall valve length of the T0 type is 12 mm [0.472 in] shorter (end cover side protrusion is 12 mm [0.472 in] less).



Unit dimensions

Number of units	L	P
2	57 [2.244]	47 [1.850]
3	76 [2.992]	66 [2.598]
4	95 [3.740]	85 [3.346]
5	114 [4.488]	104 [4.094]
6	133 [5.236]	123 [4.843]
7	152 [5.984]	142 [5.591]
8	171 [6.732]	161 [6.339]
9	190 [7.480]	180 [7.087]
10	209 [8.228]	199 [7.835]
11	228 [8.976]	218 [8.583]
12	247 [9.724]	237 [9.331]
13	266 [10.472]	256 [10.079]
14	285 [11.220]	275 [10.827]
15	304 [11.969]	294 [11.575]
16	323 [12.717]	313 [12.323]
17	342 [13.465]	332 [13.071]
18	361 [14.213]	351 [13.819]
19	380 [14.961]	370 [14.567]
20	399 [15.709]	389 [15.315]

Dimensions of F18 series split manifold non-plug-in type mm [in]



F18M Number of valves **N** **J** Pilot specifications (Base piping type)

With manifold outlet port dual use fitting block
S type plug connector

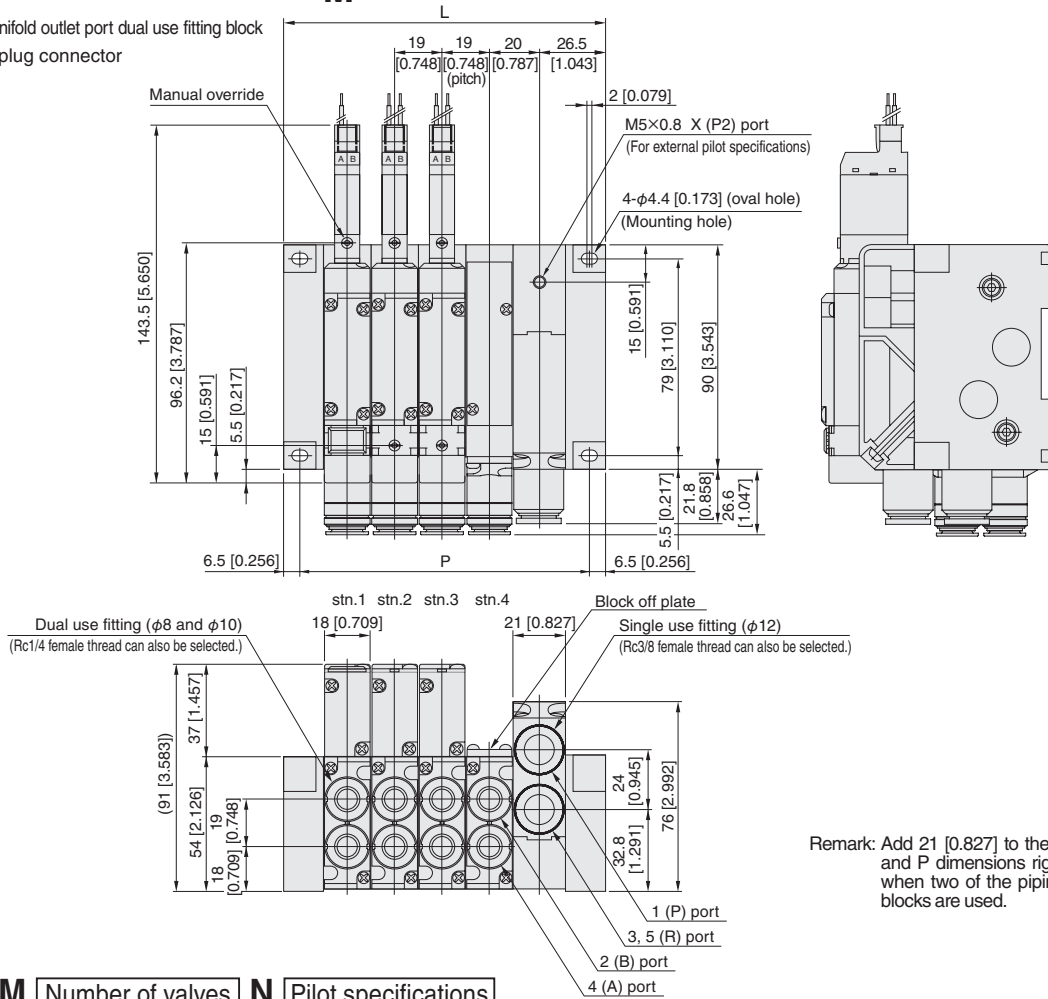

Unit dimensions

Number of units	L	P
2	91 [3.583]	78 [3.071]
3	110 [4.331]	97 [3.819]
4	129 [5.079]	116 [4.567]
5	148 [5.827]	135 [5.315]
6	167 [6.575]	154 [6.063]
7	186 [7.323]	173 [6.811]
8	205 [8.071]	192 [7.559]
9	224 [8.819]	211 [8.307]
10	243 [9.567]	230 [9.055]
11	262 [10.315]	249 [9.803]
12	281 [11.063]	268 [10.551]
13	300 [11.811]	287 [11.299]
14	319 [12.559]	306 [12.047]
15	338 [13.307]	325 [12.795]
16	357 [14.055]	344 [13.543]
17	376 [14.803]	363 [14.291]
18	395 [15.551]	382 [15.039]
19	414 [16.299]	401 [15.787]
20	433 [17.047]	420 [16.535]

Remark: Add 21 [0.827] to the L and P dimensions right when two of the piping blocks are used.



F18M Number of valves **N** Pilot specifications

(Direct piping type)

With valve outlet port dual use fitting block
S type plug connector

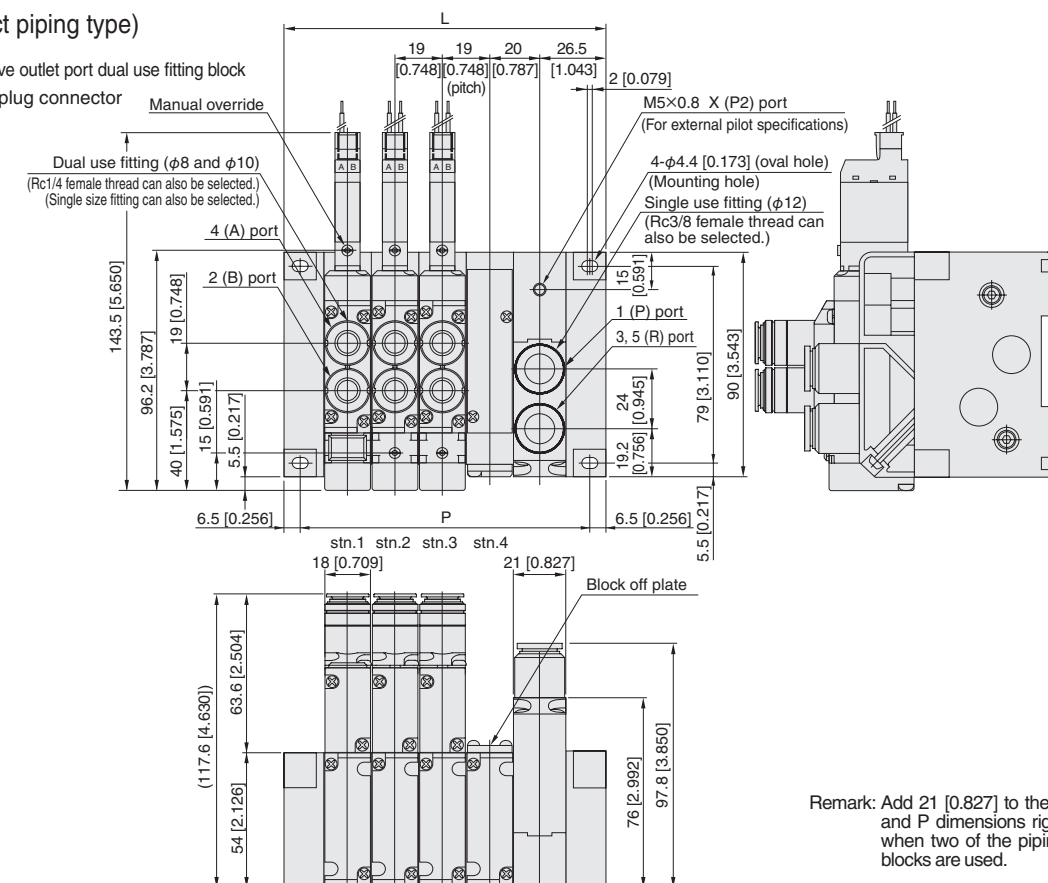

Unit dimensions

Number of units	L	P
2	91 [3.583]	78 [3.071]
3	110 [4.331]	97 [3.819]
4	129 [5.079]	116 [4.567]
5	148 [5.827]	135 [5.315]
6	167 [6.575]	154 [6.063]
7	186 [7.323]	173 [6.811]
8	205 [8.071]	192 [7.559]
9	224 [8.819]	211 [8.307]
10	243 [9.567]	230 [9.055]
11	262 [10.315]	249 [9.803]
12	281 [11.063]	268 [10.551]
13	300 [11.811]	287 [11.299]
14	319 [12.559]	306 [12.047]
15	338 [13.307]	325 [12.795]
16	357 [14.055]	344 [13.543]
17	376 [14.803]	363 [14.291]
18	395 [15.551]	382 [15.039]
19	414 [16.299]	401 [15.787]
20	433 [17.047]	420 [16.535]

Remark: Add 21 [0.827] to the L and P dimensions right when two of the piping blocks are used.

Note: The overall valve length of the T0 type is 12 mm [0.472 in] shorter (end cover side protrusion is 12 mm [0.472 in] less).

Dimensions of F18 series split manifold non-plug-in type mm [in]



F18M Number of valves NHL Pilot specifications (Base piping type)

With manifold outlet port female thread block
S type plug connector

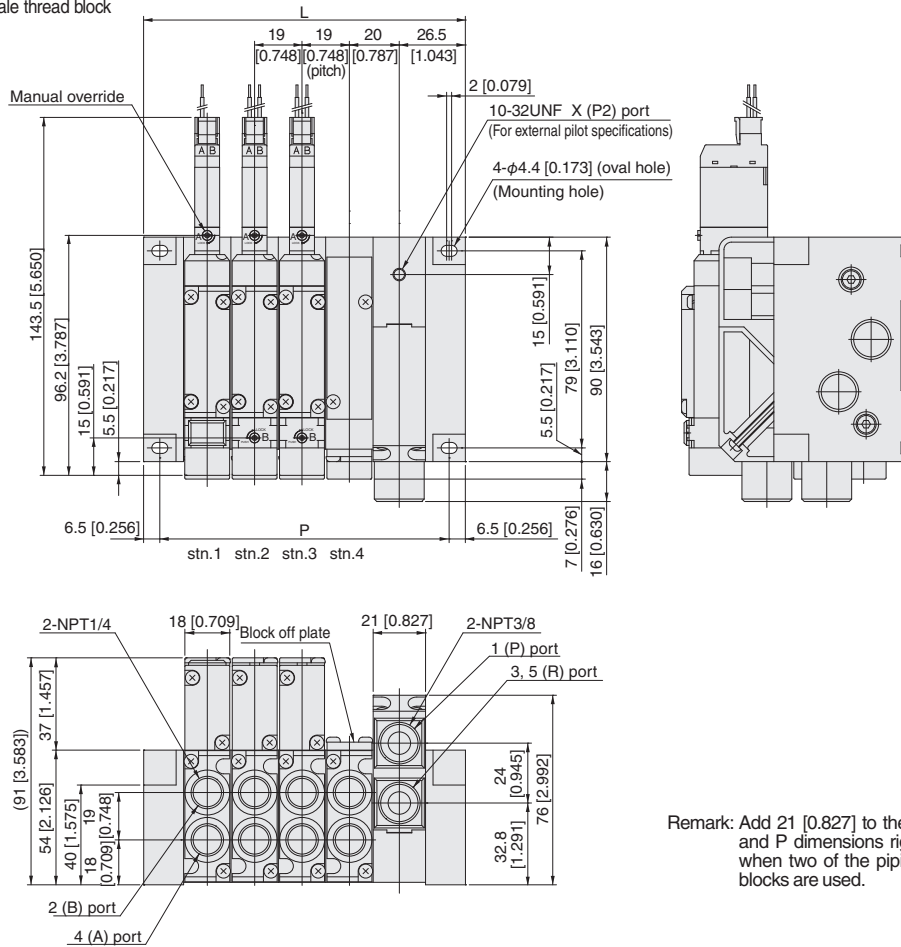

Unit dimensions

Number of units	L	P
2	91 [3.583]	78 [3.071]
3	110 [4.331]	97 [3.819]
4	129 [5.079]	116 [4.567]
5	148 [5.827]	135 [5.315]
6	167 [6.575]	154 [6.063]
7	186 [7.323]	173 [6.811]
8	205 [8.071]	192 [7.559]
9	224 [8.819]	211 [8.307]
10	243 [9.567]	230 [9.055]
11	262 [10.315]	249 [9.803]
12	281 [11.063]	268 [10.551]
13	300 [11.811]	287 [11.299]
14	319 [12.559]	306 [12.047]
15	338 [13.307]	325 [12.795]
16	357 [14.055]	344 [13.543]
17	376 [14.803]	363 [14.291]
18	395 [15.551]	382 [15.039]
19	414 [16.299]	401 [15.787]
20	433 [17.047]	420 [16.535]

Remark: Add 21 [0.827] to the L and P dimensions right when two of the piping blocks are used.



F18M Number of valves NH Pilot specifications (Direct piping type)

With valve outlet port female thread block
S type plug connector

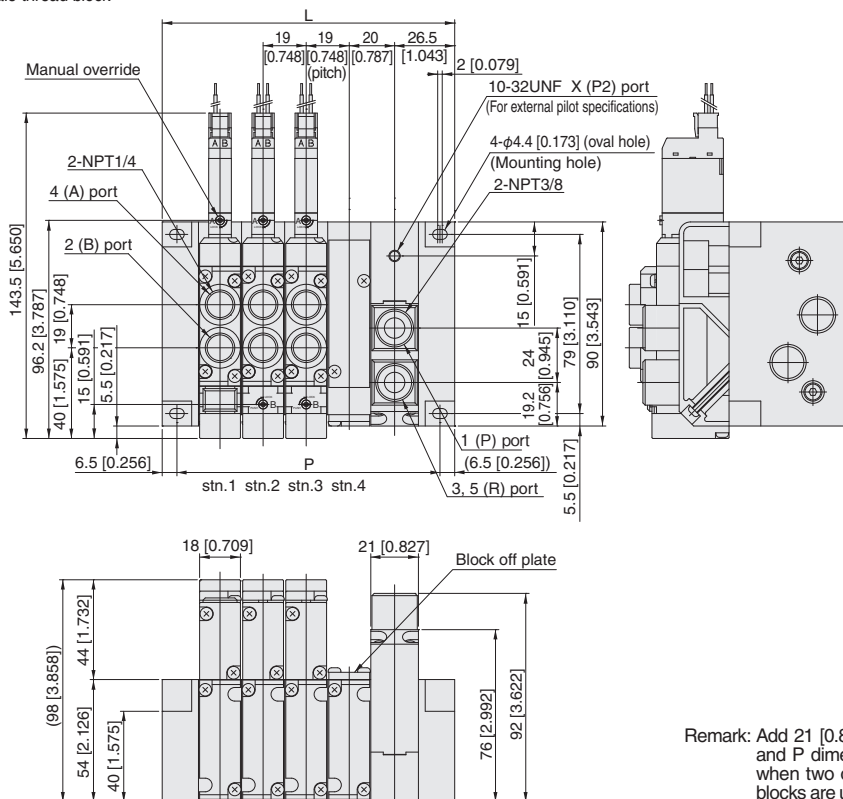

Unit dimensions

Number of units	L	P
2	91 [3.583]	78 [3.071]
3	110 [4.331]	97 [3.819]
4	129 [5.079]	116 [4.567]
5	148 [5.827]	135 [5.315]
6	167 [6.575]	154 [6.063]
7	186 [7.323]	173 [6.811]
8	205 [8.071]	192 [7.559]
9	224 [8.819]	211 [8.307]
10	243 [9.567]	230 [9.055]
11	262 [10.315]	249 [9.803]
12	281 [11.063]	268 [10.551]
13	300 [11.811]	287 [11.299]
14	319 [12.559]	306 [12.047]
15	338 [13.307]	325 [12.795]
16	357 [14.055]	344 [13.543]
17	376 [14.803]	363 [14.291]
18	395 [15.551]	382 [15.039]
19	414 [16.299]	401 [15.787]
20	433 [17.047]	420 [16.535]

Remark: Add 21 [0.827] to the L and P dimensions right when two of the piping blocks are used.

Dimensions of F18 series split manifold plug-in type mm [in]

Combination of F18MPJ and F18-CONT

F18M Number of valves P M Pilot specifications (Base piping type)

With manifold outlet port dual use fitting block
Flat cable connector 10-pin specifications

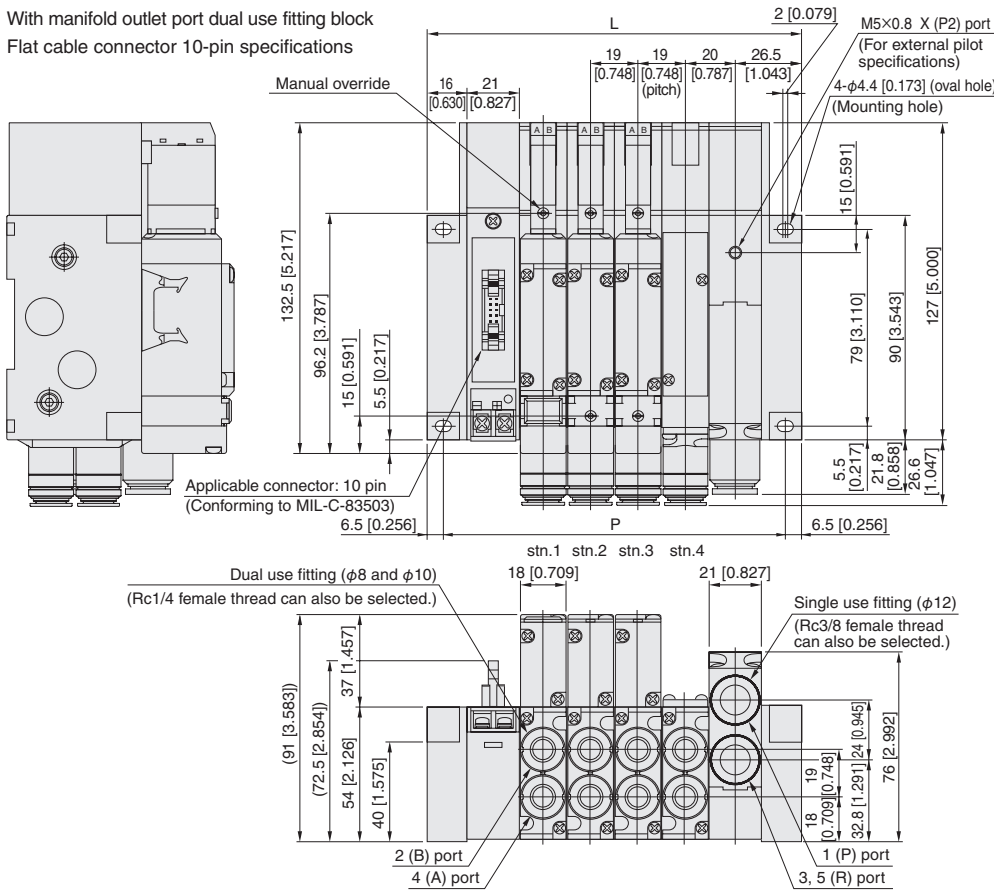

Female thread specifications

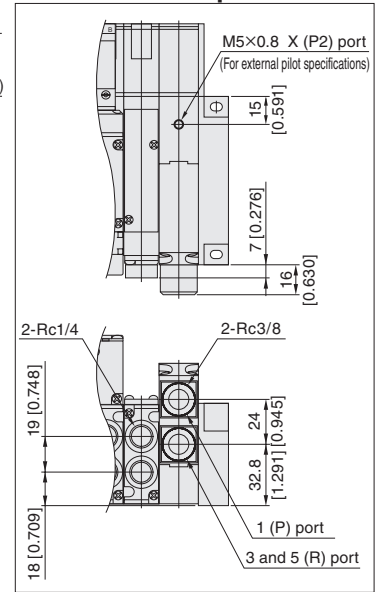

Unit dimensions

Number of units	L	P
2	112 [4.409]	99 [3.898]
3	131 [5.157]	118 [4.646]
4	150 [5.906]	137 [5.394]
5	169 [6.654]	156 [6.142]
6	188 [7.402]	175 [6.890]
7	207 [8.150]	194 [7.638]
8	226 [8.898]	213 [8.386]

Remark: Add 21 [0.827] to the L and P dimensions above when two of the piping blocks are used.

F18M Number of valves P M Pilot specifications (Base piping type)

With manifold outlet port dual use fitting block
Flat cable connector 20-pin specifications

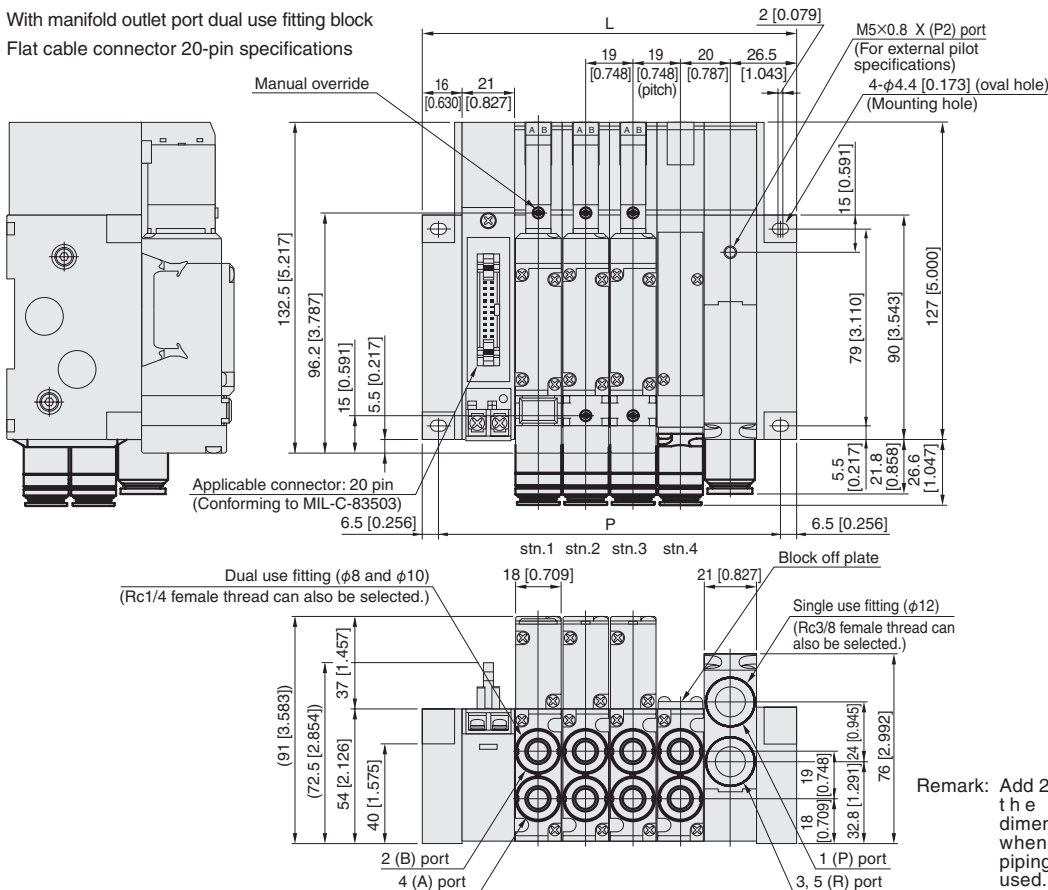

Unit dimensions

Number of units	L	P
2	112 [4.409]	99 [3.898]
3	131 [5.157]	118 [4.646]
4	150 [5.906]	137 [5.394]
5	169 [6.654]	156 [6.142]
6	188 [7.402]	175 [6.890]
7	207 [8.150]	194 [7.638]
8	226 [8.898]	213 [8.386]
9	245 [9.646]	232 [9.134]
10	264 [10.394]	251 [9.882]
11	283 [11.142]	270 [10.630]
12	302 [11.890]	289 [11.378]
13	321 [12.638]	308 [12.126]
14	340 [13.386]	327 [12.874]
15	359 [14.134]	346 [13.622]
16	378 [14.882]	365 [14.370]

Remark: Add 21 [0.827] to the L and P dimensions right when two of the piping blocks are used.

Dimensions of F18 series split manifold plug-in type mm [in]

 Combination of F18MPJ and F18-CONT

F18M Number of valves P M J Pilot specifications (Base piping type)

With manifold outlet port dual use fitting block
Flat cable connector 26-pin specifications

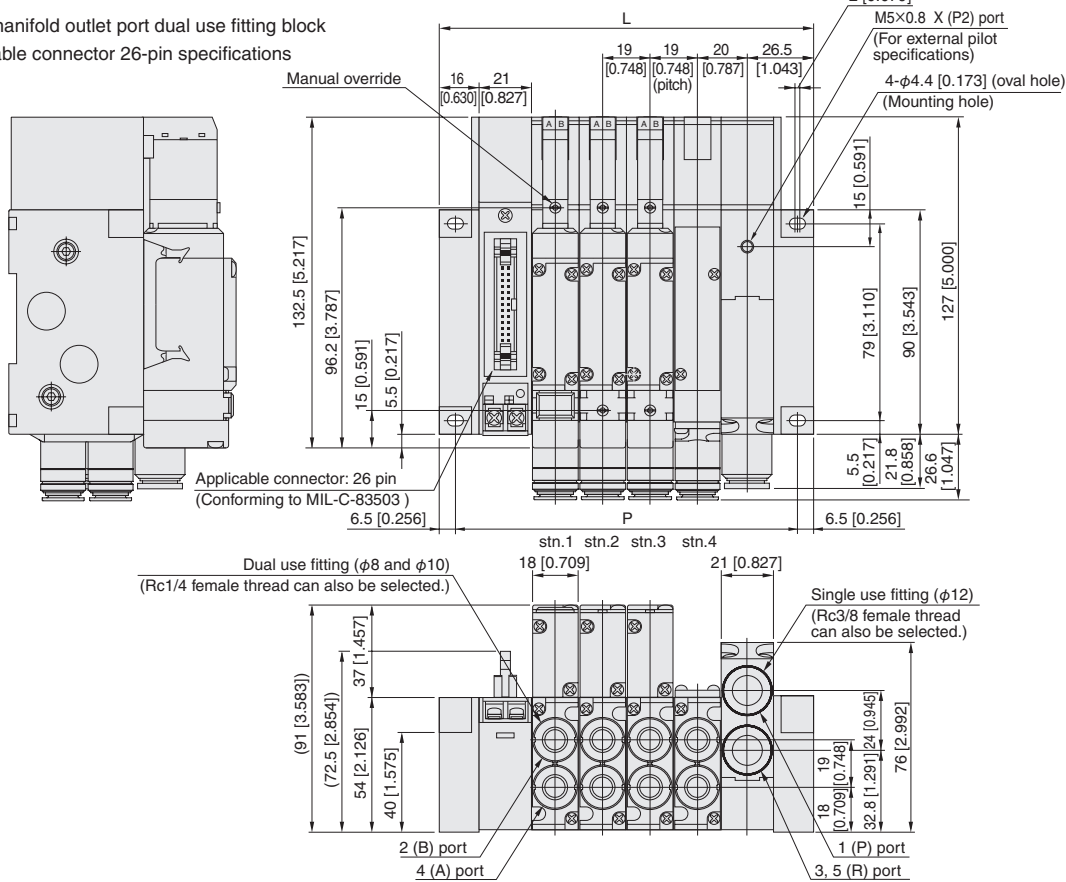

Remark: Add 21 [0.827] to the L and P dimensions right when two of the piping blocks are used.

Unit dimensions

Number of units	L	P
2	112 [4.409]	99 [3.898]
3	131 [5.157]	118 [4.646]
4	150 [5.906]	137 [5.394]
5	169 [6.654]	156 [6.142]
6	188 [7.402]	175 [6.890]
7	207 [8.150]	194 [7.638]
8	226 [8.898]	213 [8.386]
9	245 [9.646]	232 [9.134]
10	264 [10.394]	251 [9.882]
11	283 [11.142]	270 [10.630]
12	302 [11.890]	289 [11.378]
13	321 [12.638]	308 [12.126]
14	340 [13.386]	327 [12.874]
15	359 [14.134]	346 [13.622]
16	378 [14.882]	365 [14.370]
17	397 [15.630]	384 [15.118]
18	416 [16.378]	403 [15.866]
19	435 [17.126]	422 [16.614]
20	454 [17.874]	441 [17.362]

F18M Number of valves P M J Pilot specifications (Base piping type)

With manifold outlet port dual use fitting block
D-sub connector 25-pin specifications

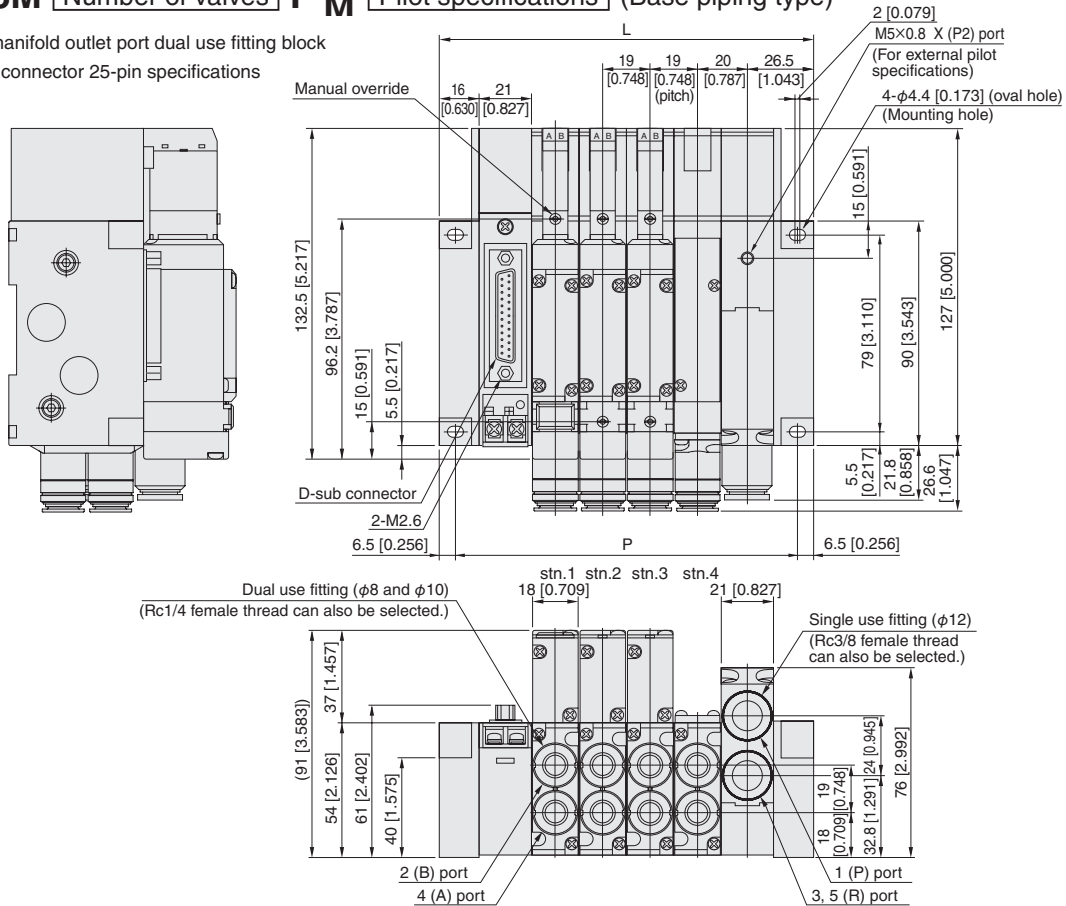

Remark: Add 21 [0.827] to the L and P dimensions right when two of the piping blocks are used.

Unit dimensions

Number of units	L	P
2	112 [4.409]	99 [3.898]
3	131 [5.157]	118 [4.646]
4	150 [5.906]	137 [5.394]
5	169 [6.654]	156 [6.142]
6	188 [7.402]	175 [6.890]
7	207 [8.150]	194 [7.638]
8	226 [8.898]	213 [8.386]
9	245 [9.646]	232 [9.134]
10	264 [10.394]	251 [9.882]
11	283 [11.142]	270 [10.630]
12	302 [11.890]	289 [11.378]
13	321 [12.638]	308 [12.126]
14	340 [13.386]	327 [12.874]
15	359 [14.134]	346 [13.622]
16	378 [14.882]	365 [14.370]
17	397 [15.630]	384 [15.118]
18	416 [16.378]	403 [15.866]
19	435 [17.126]	422 [16.614]
20	454 [17.874]	441 [17.362]

Dimensions of F18 series split manifold plug-in type mm [in]

F18M Number of valves PHL Pilot specifications (Base piping type)

 Combination of F18MPJ and F18-CONT

With manifold outlet port female thread block
Flat cable connector 10-pin specifications

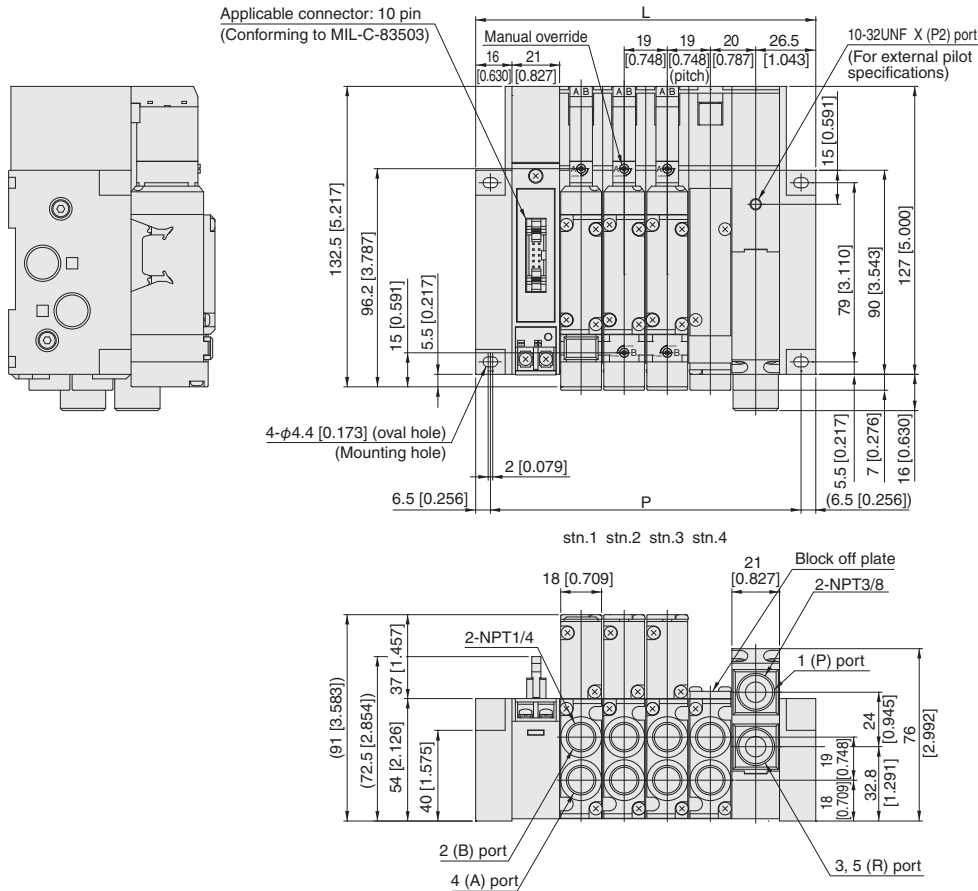

Unit dimensions

Number of units	L	P
2	112 [4.409]	99 [3.898]
3	131 [5.157]	118 [4.646]
4	150 [5.906]	137 [5.394]
5	169 [6.654]	156 [6.142]
6	188 [7.402]	175 [6.890]
7	207 [8.150]	194 [7.638]
8	226 [8.898]	213 [8.386]

Remark: Add 21 [0.827] to the L and P dimensions above when two of the piping blocks are used.

F18M Number of valves PH Pilot specifications (Direct piping type)

With valve outlet port female thread block
Flat cable connector 10-pin specifications

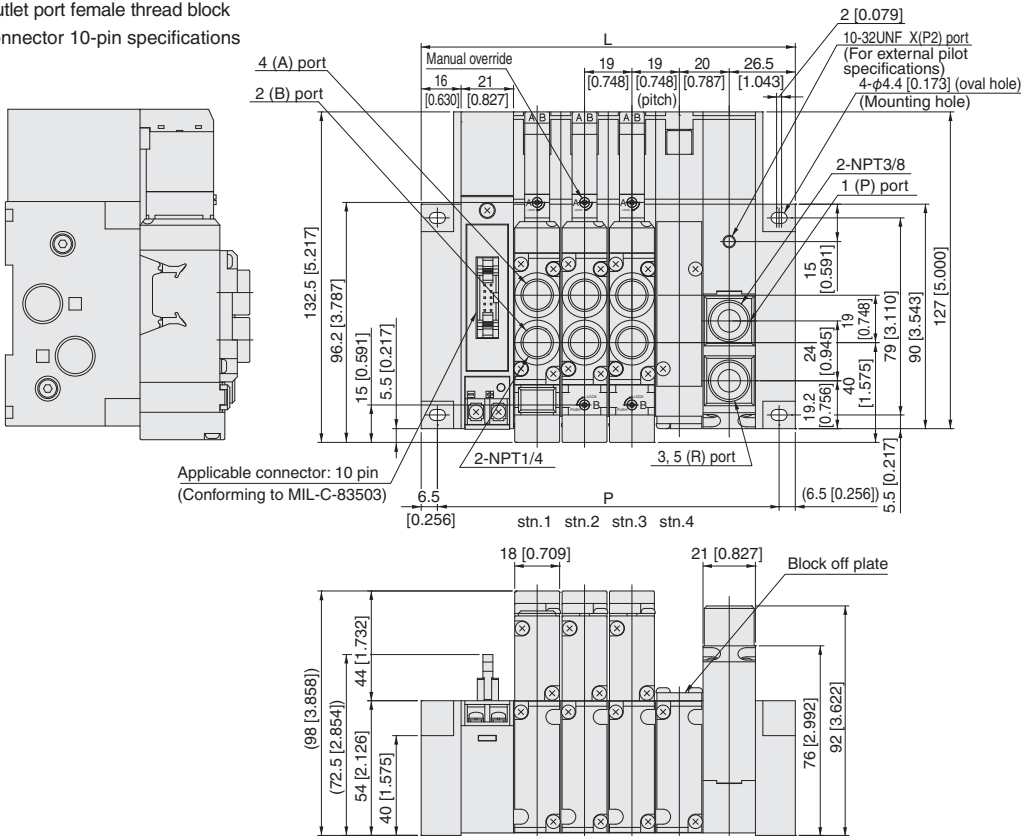

Unit dimensions

Number of units	L	P
2	112 [4.409]	99 [3.898]
3	131 [5.157]	118 [4.646]
4	150 [5.906]	137 [5.394]
5	169 [6.654]	156 [6.142]
6	188 [7.402]	175 [6.890]
7	207 [8.150]	194 [7.638]
8	226 [8.898]	213 [8.386]

Remark: Add 21 [0.827] to the L and P dimensions above when two of the piping blocks are used.

Dimensions of F18 series split manifold plug-in type mm [in]

F18M Number of valves PHL Pilot specifications (Base piping type)



Combination of F18MPJ and F18-CONT

With manifold outlet port female thread block
Flat cable connector 20-pin specifications

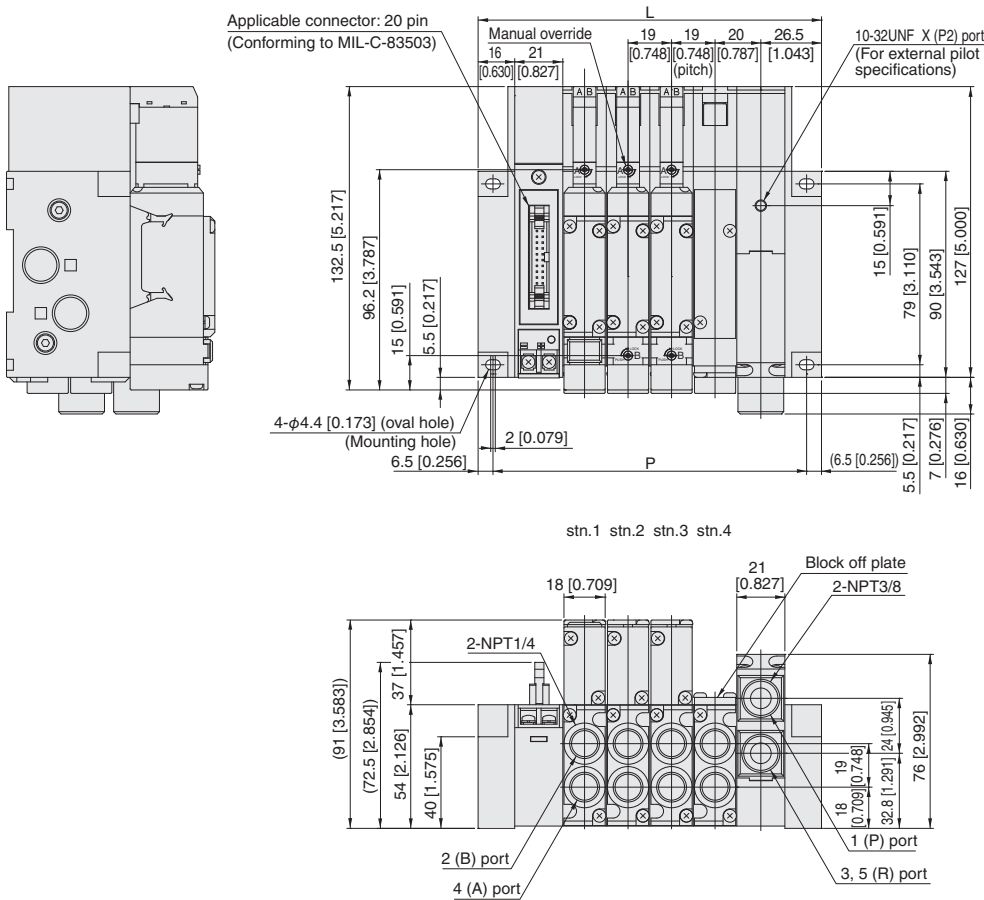

Unit dimensions

Number of units	L	P
2	112 [4.409]	99 [3.898]
3	131 [5.157]	118 [4.646]
4	150 [5.906]	137 [5.394]
5	169 [6.654]	156 [6.142]
6	188 [7.402]	175 [6.890]
7	207 [8.150]	194 [7.638]
8	226 [8.898]	213 [8.386]
9	245 [9.646]	232 [9.134]
10	264 [10.394]	251 [9.882]
11	283 [11.142]	270 [10.630]
12	302 [11.890]	289 [11.378]
13	321 [12.638]	308 [12.126]
14	340 [13.386]	327 [12.874]
15	359 [14.134]	346 [13.622]
16	378 [14.882]	365 [14.370]

Remark: Add 21 [0.827] to the L and P dimensions above when two of the piping blocks are used.

F18M Number of valves PH Pilot specifications (Direct piping type)

With valve outlet port female thread block
Flat cable connector 20-pin specifications

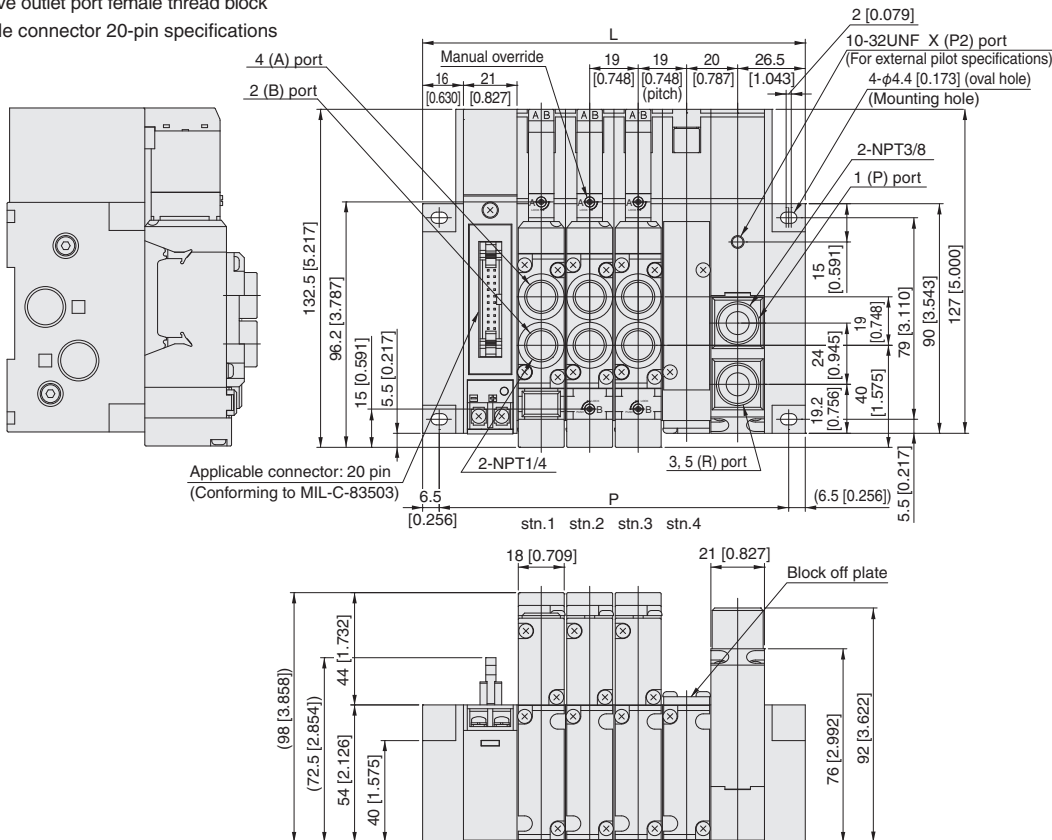

Unit dimensions

Number of units	L	P
2	112 [4.409]	99 [3.898]
3	131 [5.157]	118 [4.646]
4	150 [5.906]	137 [5.394]
5	169 [6.654]	156 [6.142]
6	188 [7.402]	175 [6.890]
7	207 [8.150]	194 [7.638]
8	226 [8.898]	213 [8.386]
9	245 [9.646]	232 [9.134]
10	264 [10.394]	251 [9.882]
11	283 [11.142]	270 [10.630]
12	302 [11.890]	289 [11.378]
13	321 [12.638]	308 [12.126]
14	340 [13.386]	327 [12.874]
15	359 [14.134]	346 [13.622]
16	378 [14.882]	365 [14.370]

Remark: Add 21 [0.827] to the L and P dimensions above when two of the piping blocks are used.

F18 SERIES

Dimensions of F18 series split manifold plug-in type mm [in]

 Combination of F18MPJ and F18-CONT

F18M Number of valves PHL Pilot specifications (Base piping type)

With manifold outlet port female thread block
Flat cable connector 26-pin specifications

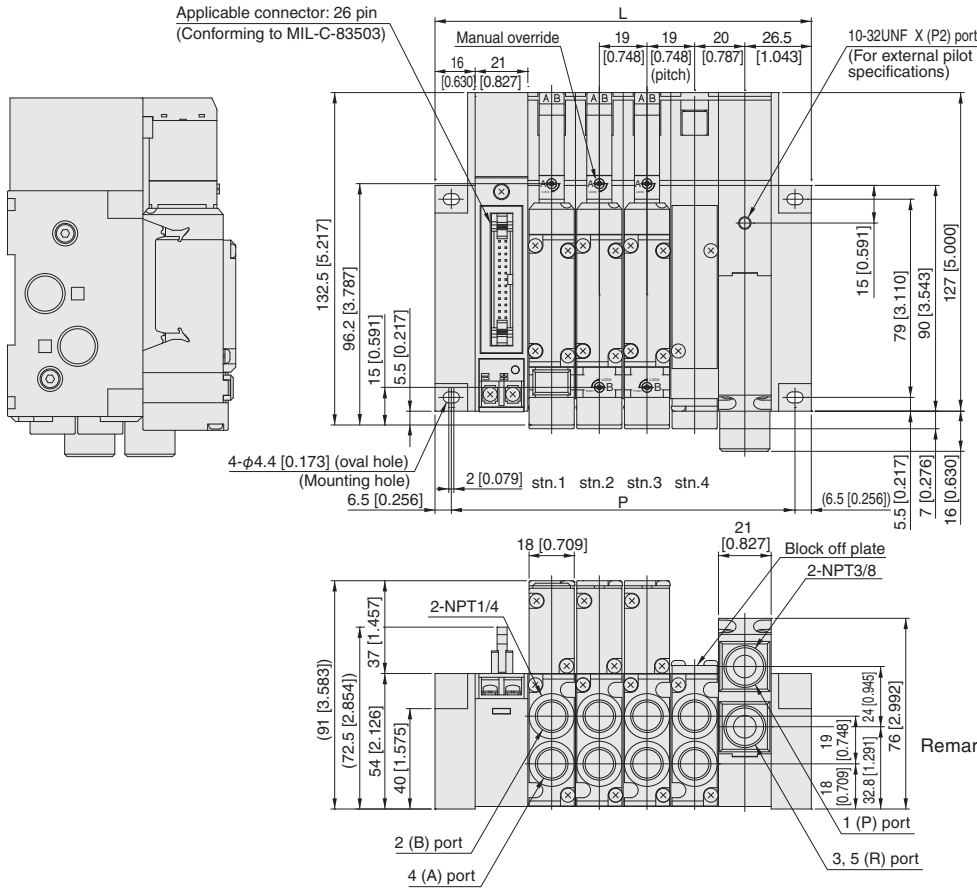

Unit dimensions

Number of units	L	P
2	112 [4.409]	99 [3.898]
3	131 [5.157]	118 [4.646]
4	150 [5.906]	137 [5.394]
5	169 [6.654]	156 [6.142]
6	188 [7.402]	175 [6.890]
7	207 [8.150]	194 [7.638]
8	226 [8.898]	213 [8.386]
9	245 [9.646]	232 [9.134]
10	264 [10.394]	251 [9.882]
11	283 [11.142]	270 [10.630]
12	302 [11.890]	289 [11.378]
13	321 [12.638]	308 [12.126]
14	340 [13.386]	327 [12.874]
15	359 [14.134]	346 [13.622]
16	378 [14.882]	365 [14.370]
17	397 [15.630]	384 [15.118]
18	416 [16.378]	403 [15.866]
19	435 [17.126]	422 [16.614]
20	454 [17.874]	441 [17.362]

Remark: Add 21 [0.827] to the L and P dimensions right when two of the piping blocks are used.

 Combination of F18MPJ and F18-CONT

F18M Number of valves PH Pilot specifications (Direct piping type)

With valve outlet port female thread block
Flat cable connector 26-pin specifications

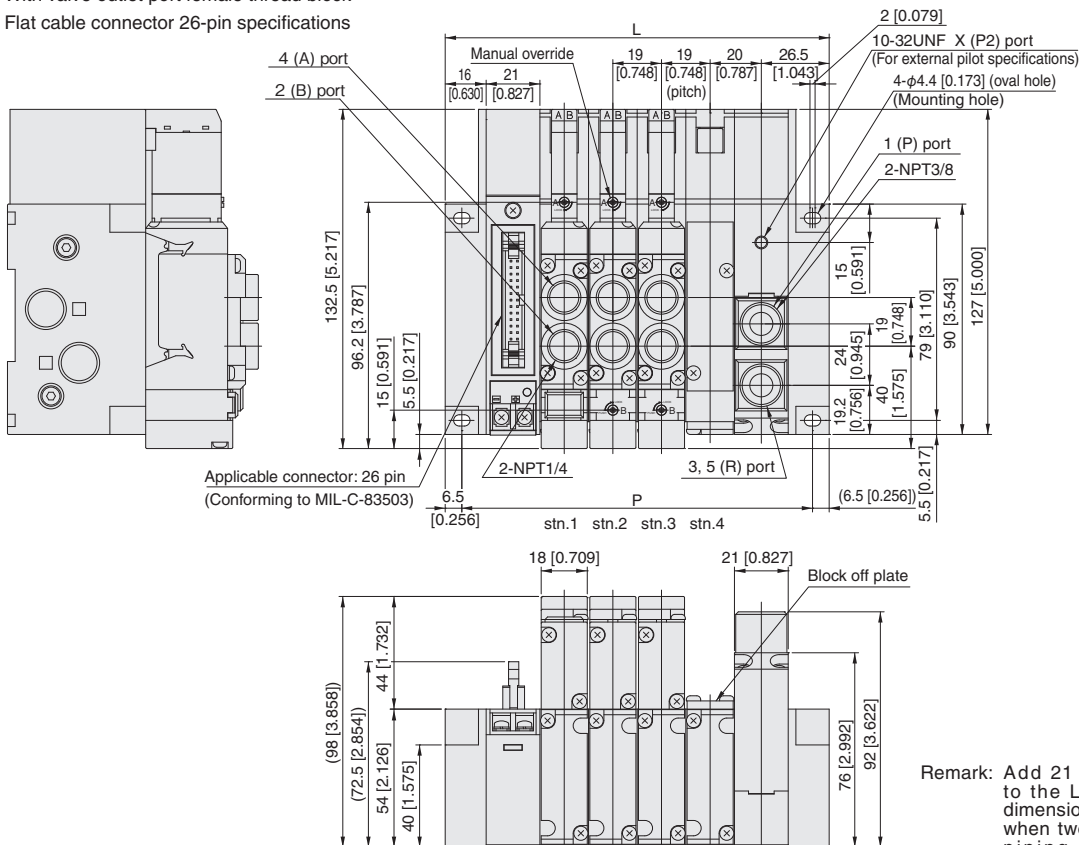

Unit dimensions

Number of units	L	P
2	112 [4.409]	99 [3.898]
3	131 [5.157]	118 [4.646]
4	150 [5.906]	137 [5.394]
5	169 [6.654]	156 [6.142]
6	188 [7.402]	175 [6.890]
7	207 [8.150]	194 [7.638]
8	226 [8.898]	213 [8.386]
9	245 [9.646]	232 [9.134]
10	264 [10.394]	251 [9.882]
11	283 [11.142]	270 [10.630]
12	302 [11.890]	289 [11.378]
13	321 [12.638]	308 [12.126]
14	340 [13.386]	327 [12.874]
15	359 [14.134]	346 [13.622]
16	378 [14.882]	365 [14.370]
17	397 [15.630]	384 [15.118]
18	416 [16.378]	403 [15.866]
19	435 [17.126]	422 [16.614]
20	454 [17.874]	441 [17.362]

Remark: Add 21 [0.827] to the L and P dimensions right when two of the piping blocks are used.

Dimensions of F18 series split manifold plug-in type mm [in]

F18M Number of valves PHL Pilot specifications (Base piping type)

With manifold outlet port female thread block

D-sub connector 25-pin specifications Manual override

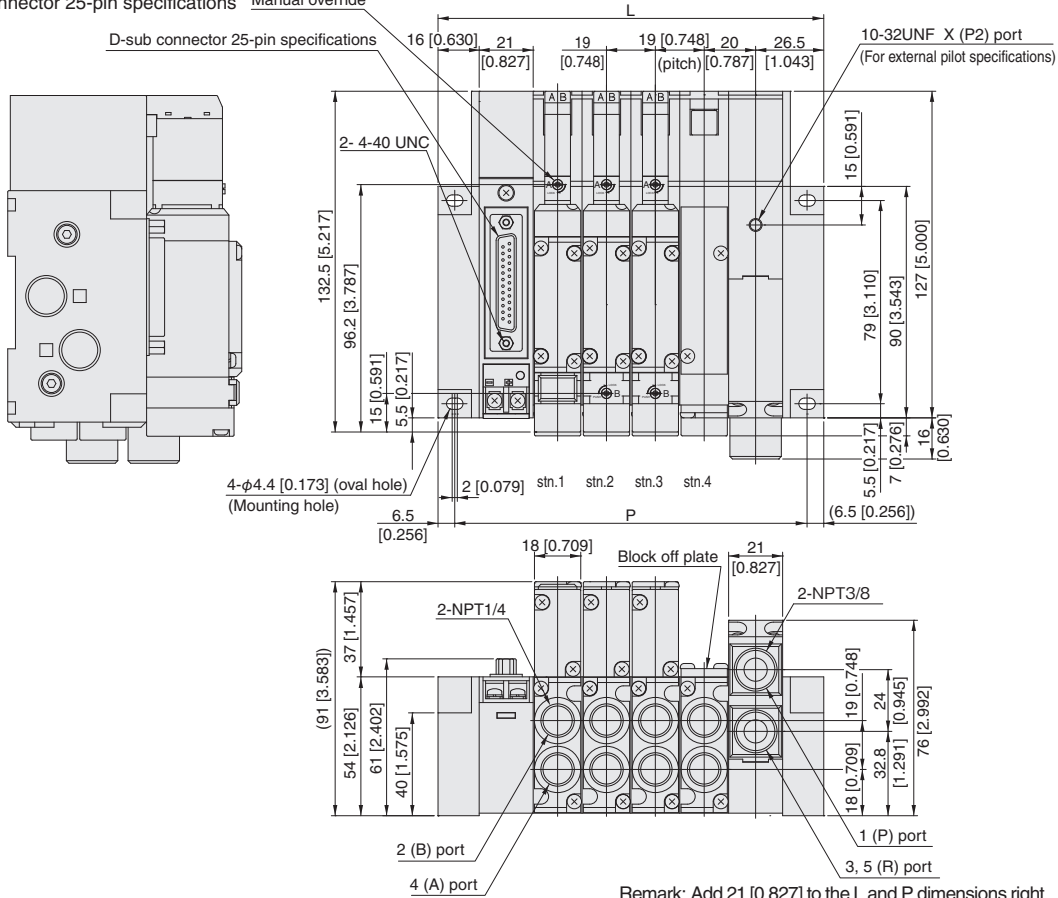

Remark: Add 21 [0.827] to the L and P dimensions right when two of the piping blocks are used.

F18M Number of valves PH Pilot specifications (Direct piping type)

With valve outlet port female thread block

D-sub connector 25-pin specifications

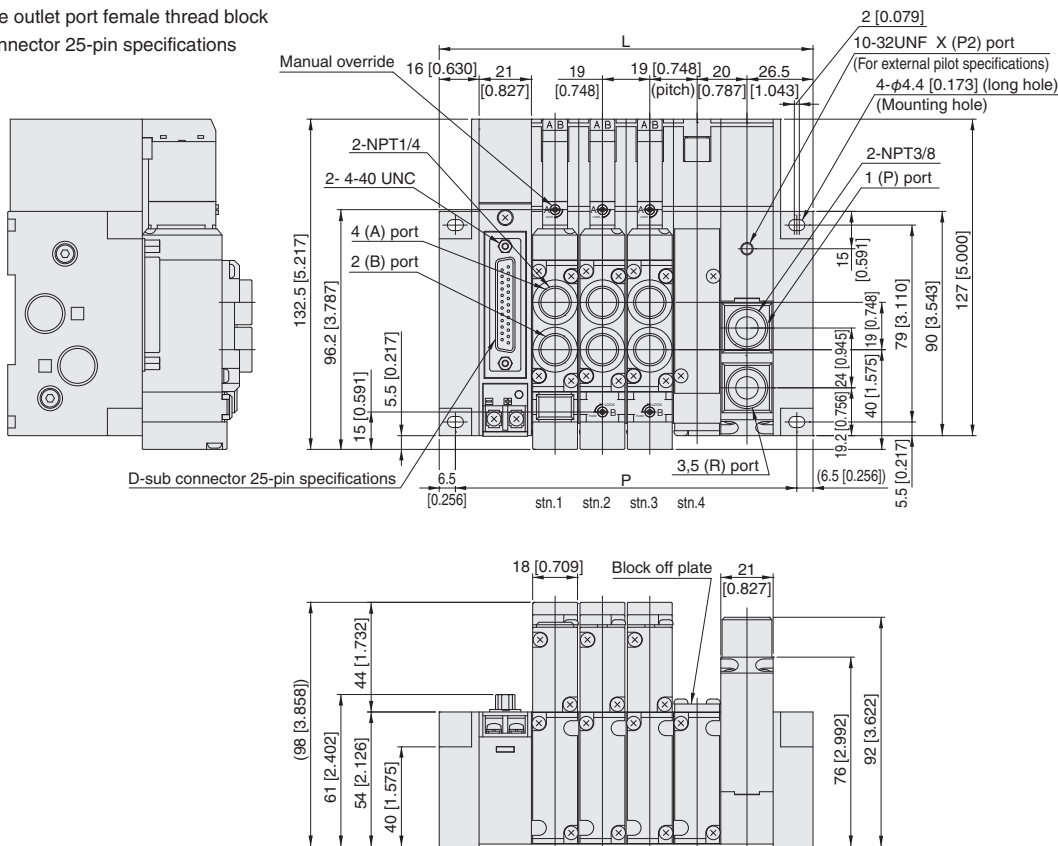

Remark: Add 21 [0.827] to the L and P dimensions right when two of the piping blocks are used.

Unit dimensions

Number of units	L	P
2	112 [4.409]	99 [3.898]
3	131 [5.157]	118 [4.646]
4	150 [5.906]	137 [5.394]
5	169 [6.654]	156 [6.142]
6	188 [7.402]	175 [6.890]
7	207 [8.150]	194 [7.638]
8	226 [8.898]	213 [8.386]
9	245 [9.646]	232 [9.134]
10	264 [10.394]	251 [9.882]
11	283 [11.142]	270 [10.630]
12	302 [11.890]	289 [11.378]
13	321 [12.638]	308 [12.126]
14	340 [13.386]	327 [12.874]
15	359 [14.134]	346 [13.622]
16	378 [14.882]	365 [14.370]
17	397 [15.630]	384 [15.118]
18	416 [16.378]	403 [15.866]
19	435 [17.126]	422 [16.614]
20	454 [17.874]	441 [17.362]

Remark

Unit dimensions

Number of units	L	P
2	112 [4.409]	99 [3.898]
3	131 [5.157]	118 [4.646]
4	150 [5.906]	137 [5.394]
5	169 [6.654]	156 [6.142]
6	188 [7.402]	175 [6.890]
7	207 [8.150]	194 [7.638]
8	226 [8.898]	213 [8.386]
9	245 [9.646]	232 [9.134]
10	264 [10.394]	251 [9.882]
11	283 [11.142]	270 [10.630]
12	302 [11.890]	289 [11.378]
13	321 [12.638]	308 [12.126]
14	340 [13.386]	327 [12.874]
15	359 [14.134]	346 [13.622]
16	378 [14.882]	365 [14.370]
17	397 [15.630]	384 [15.118]
18	416 [16.378]	403 [15.866]
19	435 [17.126]	422 [16.614]
20	454 [17.874]	441 [17.362]

Remark

Dimensions of F18 series split manifold plug-in type mm [in]

F18M Number of valves **PHL** Pilot specifications (Base piping type)

With manifold outlet port female thread block
D-sub connector 37-pin specifications

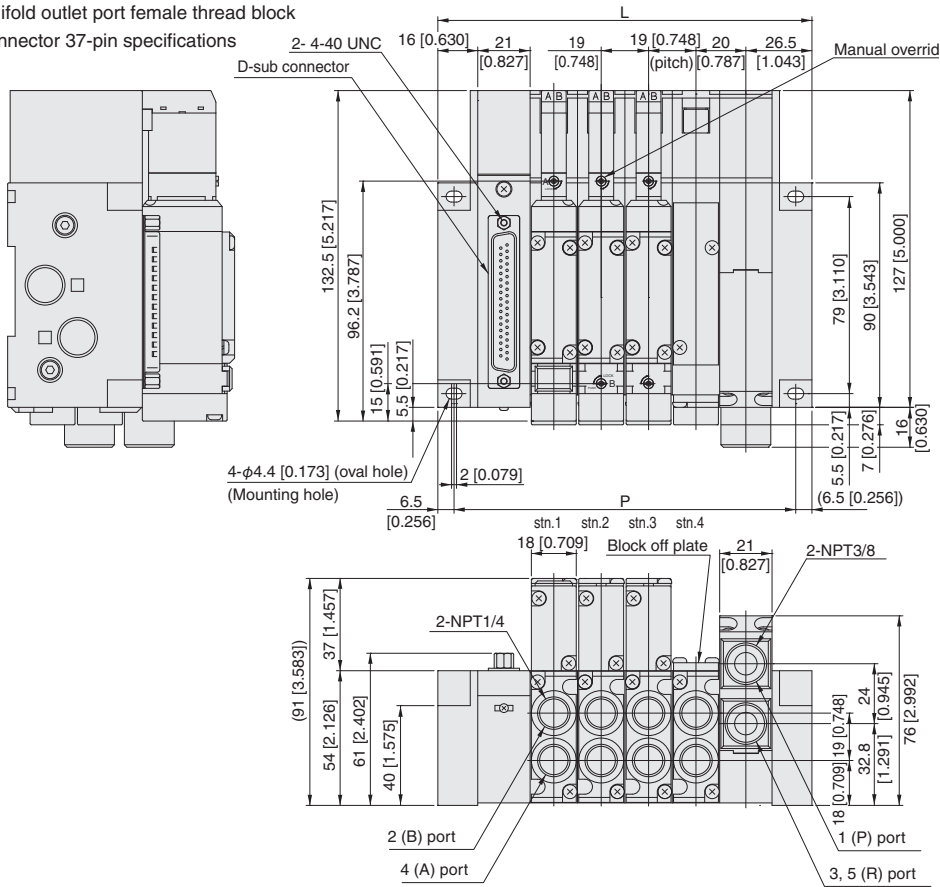

Remark: Add 21 [0.827] to the L and P dimensions right when two of the piping blocks are used.

Unit dimensions

Number of units	L	P
2	112 [4.409]	99 [3.898]
3	131 [5.157]	118 [4.646]
4	150 [5.906]	137 [5.394]
5	169 [6.654]	156 [6.142]
6	188 [7.402]	175 [6.890]
7	207 [8.150]	194 [7.638]
8	226 [8.898]	213 [8.386]
9	245 [9.646]	232 [9.134]
10	264 [10.394]	251 [9.882]
11	283 [11.142]	270 [10.630]
12	302 [11.890]	289 [11.378]
13	321 [12.638]	308 [12.126]
14	340 [13.386]	327 [12.874]
15	359 [14.134]	346 [13.622]
16	378 [14.882]	365 [14.370]
17	397 [15.630]	384 [15.118]
18	416 [16.378]	403 [15.866]
19	435 [17.126]	422 [16.614]
20	454 [17.874]	441 [17.362]

Remark

F18M Number of valves **PH** Pilot specifications (Direct piping type)

With valve outlet port female thread block
D-sub connector 37-pin specifications

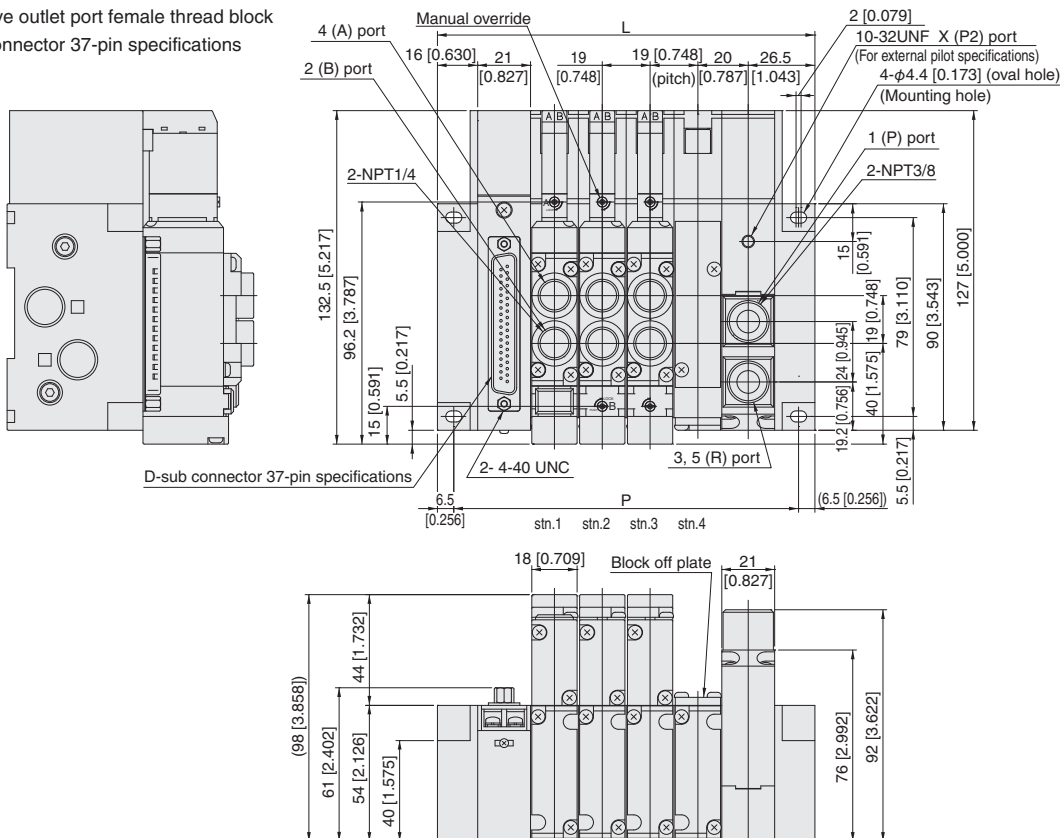

Remark: Add 21 [0.827] to the L and P dimensions right when two of the piping blocks are used.

Unit dimensions

Number of units	L	P
2	112 [4.409]	99 [3.898]
3	131 [5.157]	118 [4.646]
4	150 [5.906]	137 [5.394]
5	169 [6.654]	156 [6.142]
6	188 [7.402]	175 [6.890]
7	207 [8.150]	194 [7.638]
8	226 [8.898]	213 [8.386]
9	245 [9.646]	232 [9.134]
10	264 [10.394]	251 [9.882]
11	283 [11.142]	270 [10.630]
12	302 [11.890]	289 [11.378]
13	321 [12.638]	308 [12.126]
14	340 [13.386]	327 [12.874]
15	359 [14.134]	346 [13.622]
16	378 [14.882]	365 [14.370]
17	397 [15.630]	384 [15.118]
18	416 [16.378]	403 [15.866]
19	435 [17.126]	422 [16.614]
20	454 [17.874]	441 [17.362]

Remark

Dimensions of F18 series split manifold plug-in type mm [in]

 Combination of F18MPJ and F18-CONT

F18M Number of valves PHL Pilot specifications (Base piping type)

With manifold outlet port female thread block
Terminal block type

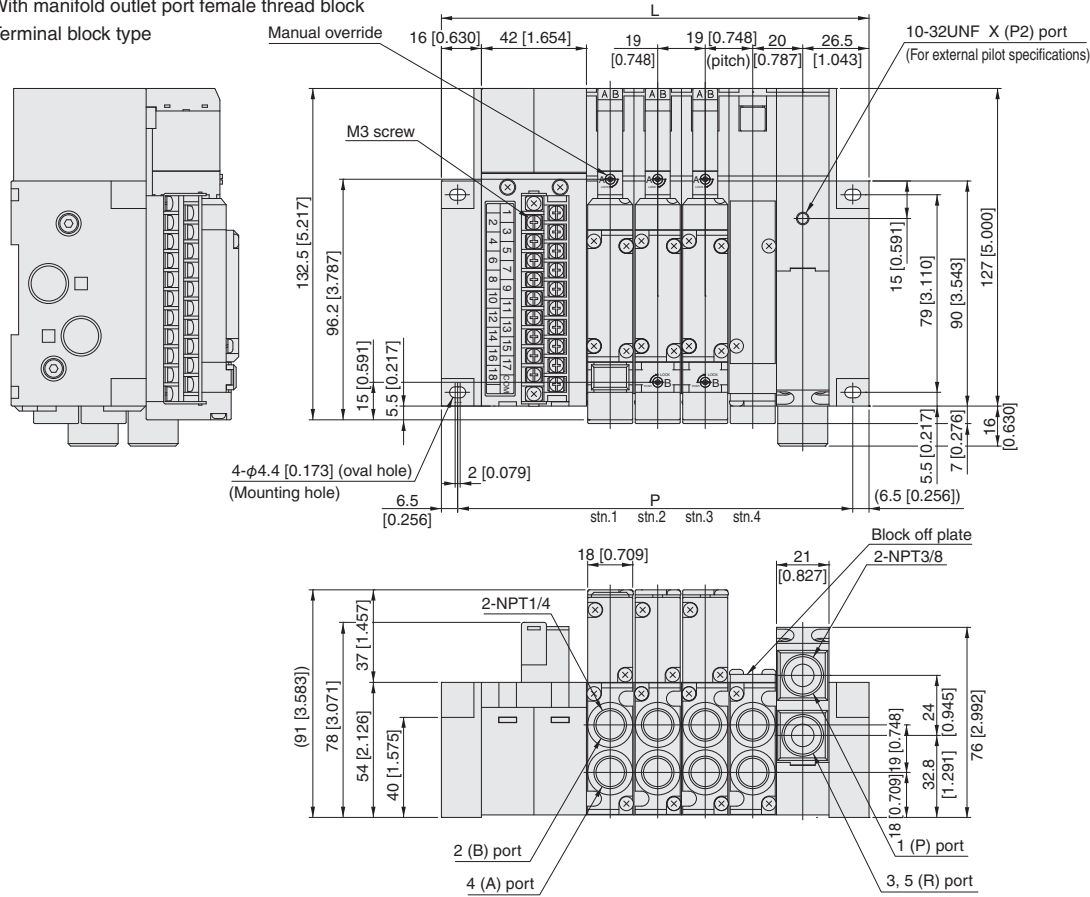

Unit dimensions

Number of units	L	P
2	133 [5.236]	120 [4.724]
3	152 [5.984]	139 [5.472]
4	171 [6.732]	158 [6.220]
5	190 [7.480]	177 [6.969]
6	209 [8.228]	196 [7.717]
7	228 [8.976]	215 [8.465]
8	247 [9.724]	234 [9.213]
9	266 [10.472]	253 [9.961]
10	285 [11.220]	272 [10.709]
11	304 [11.969]	291 [11.457]
12	323 [12.717]	310 [12.205]
13	342 [13.465]	329 [12.953]
14	361 [14.213]	348 [13.701]
15	380 [14.961]	367 [14.449]
16	399 [15.709]	386 [15.197]
17	418 [16.457]	405 [15.945]
18	437 [17.205]	424 [16.693]

Remark: Add 21 [0.827] to the L and P dimensions above when two of the piping blocks are used.

F18M Number of valves PH Pilot specifications (Direct piping type)

With valve outlet port female thread block
Terminal block type

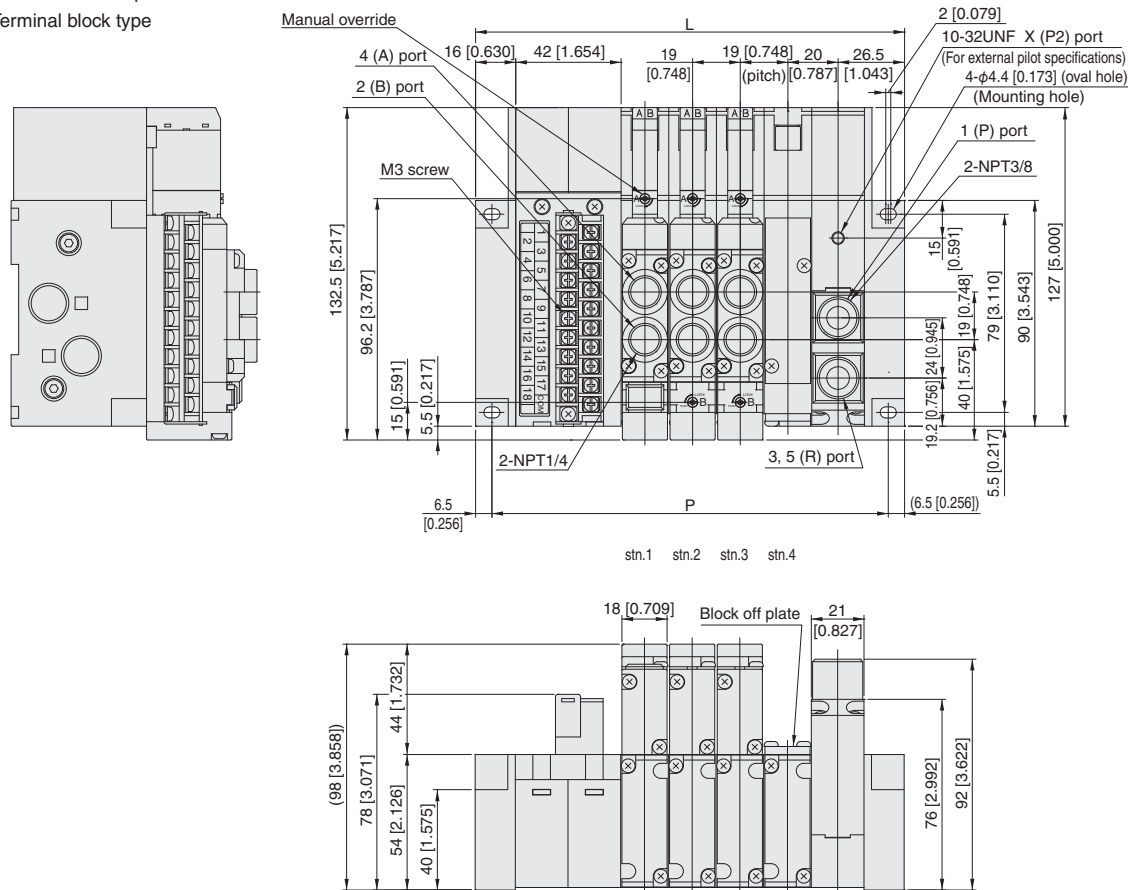

Unit dimensions

Number of units	L	P
2	133 [5.236]	120 [4.724]
3	152 [5.984]	139 [5.472]
4	171 [6.732]	158 [6.220]
5	190 [7.480]	177 [6.969]
6	209 [8.228]	196 [7.717]
7	228 [8.976]	215 [8.465]
8	247 [9.724]	234 [9.213]
9	266 [10.472]	253 [9.961]
10	285 [11.220]	272 [10.709]
11	304 [11.969]	291 [11.457]
12	323 [12.717]	310 [12.205]
13	342 [13.465]	329 [12.953]
14	361 [14.213]	348 [13.701]
15	380 [14.961]	367 [14.449]
16	399 [15.709]	386 [15.197]
17	418 [16.457]	405 [15.945]
18	437 [17.205]	424 [16.693]

Remark: Add 21 [0.827] to the L and P dimensions above when two of the piping blocks are used.

Dimensions of F18 series serial transmission compatible manifold mm [in]

* For CompoNet compatible dimensions, see page 154.

F18M Number of valves **S** **J** Pilot specifications (Base piping type)



With manifold outlet port dual use fitting block

(Models that support integrated serial transmission block)

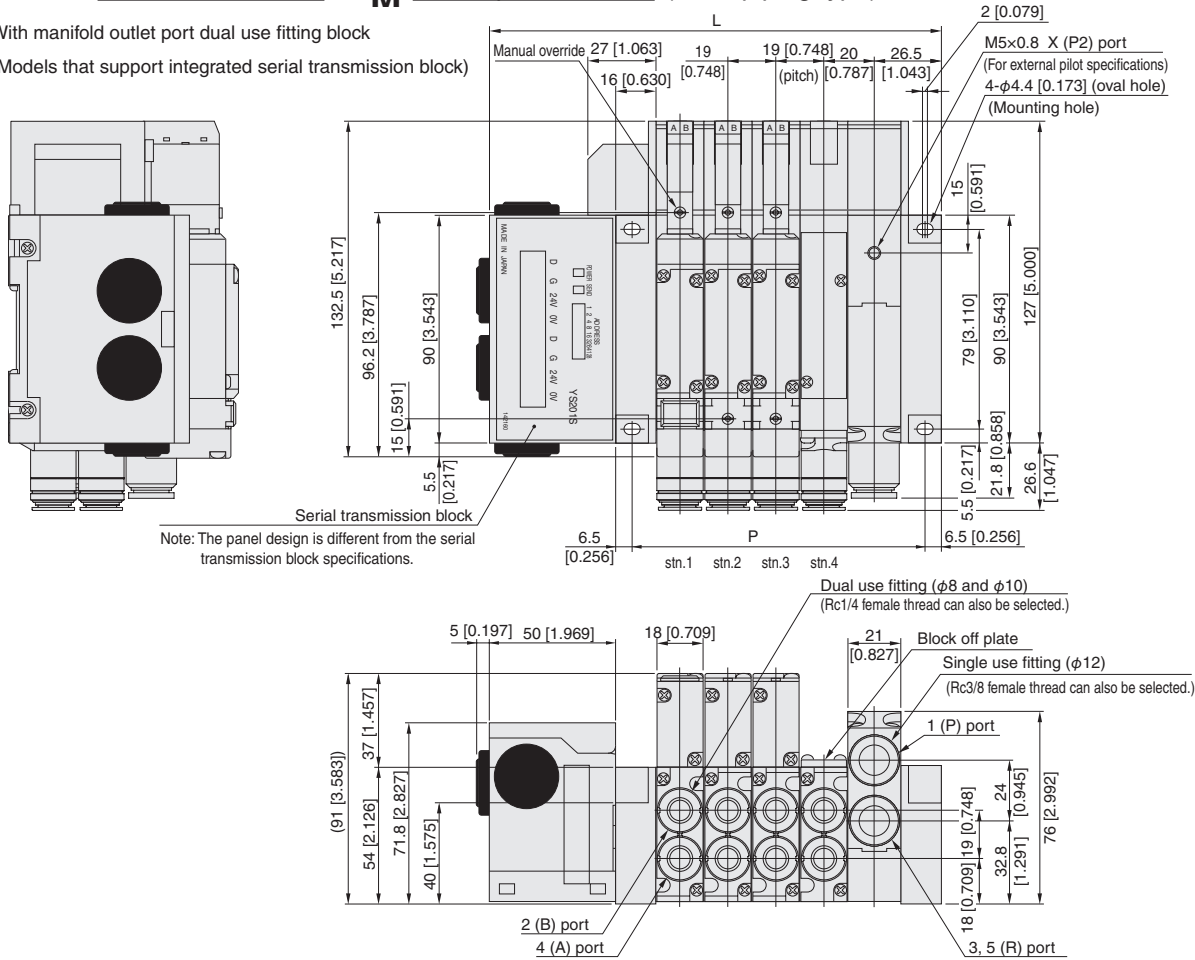

F18M Number of valves **S** (Direct piping type)



With valve outlet port dual use fitting block

(Models that support integrated serial transmission block)

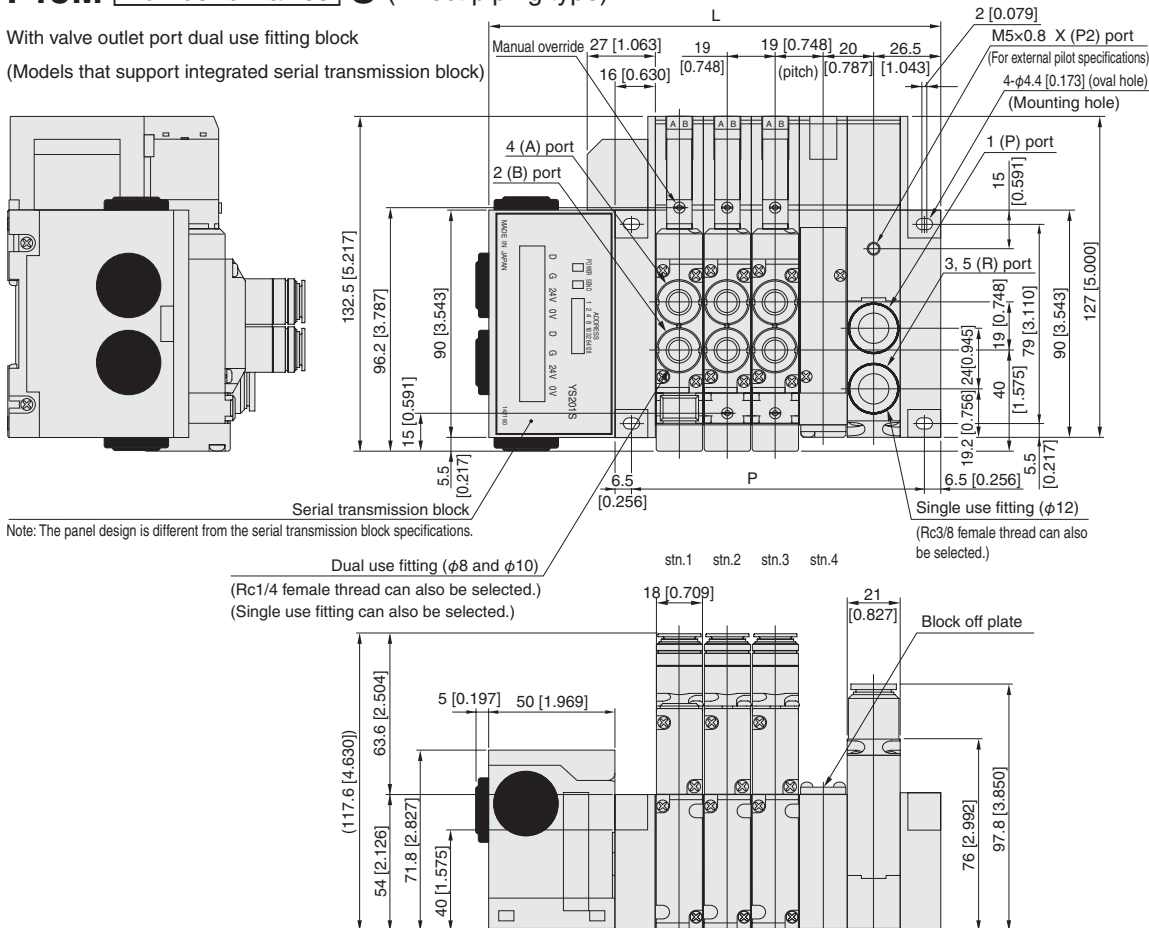

Unit dimensions

Number of units	L	P
2	141 [5.551]	78 [3.071]
3	160 [6.299]	97 [3.819]
4	179 [7.047]	116 [4.567]
5	198 [7.795]	135 [5.315]
6	217 [8.543]	154 [6.063]
7	236 [9.291]	173 [6.811]
8	255 [10.039]	192 [7.559]
9	274 [10.787]	211 [8.307]
10	293 [11.535]	230 [9.055]
11	312 [12.283]	249 [9.803]
12	331 [13.031]	268 [10.551]
13	350 [13.780]	287 [11.299]
14	369 [14.528]	306 [12.047]
15	388 [15.276]	325 [12.795]
16	407 [16.024]	344 [13.543]

Remark: Add 21 [0.827] to the L and P dimensions above when two of the piping blocks are used.

Dimensions of F18 series serial transmission compatible manifold mm [in]

* For CompoNet compatible dimensions, see page 154.

F18M Number of valves SHL Pilot specifications (Base piping type)



With manifold outlet port female thread block

(Models that support integrated serial transmission block)

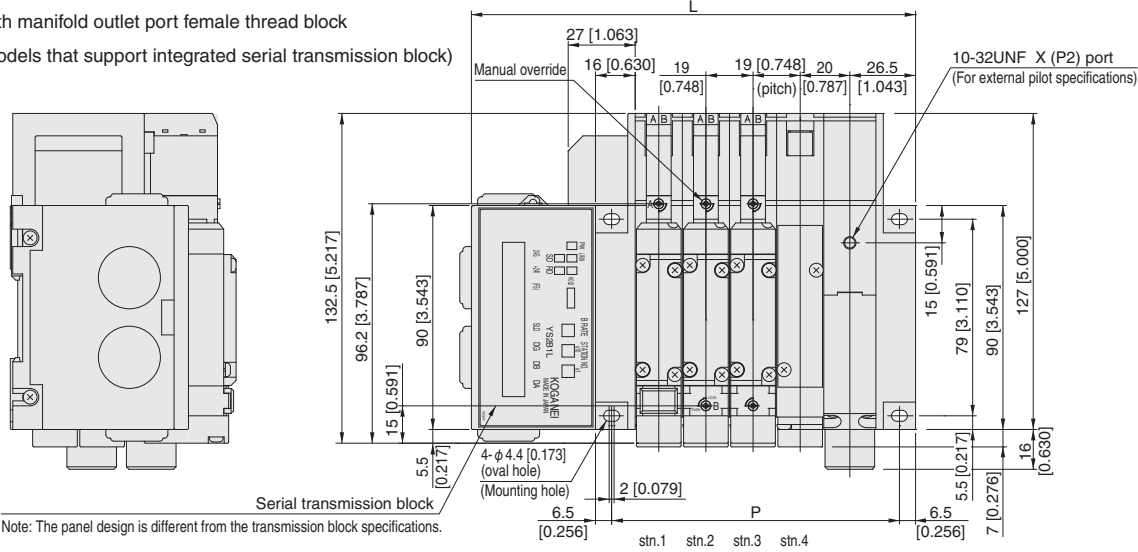

F18M Number of valves S (Direct piping type)



With valve outlet port female thread block

(Models that support integrated serial transmission block)

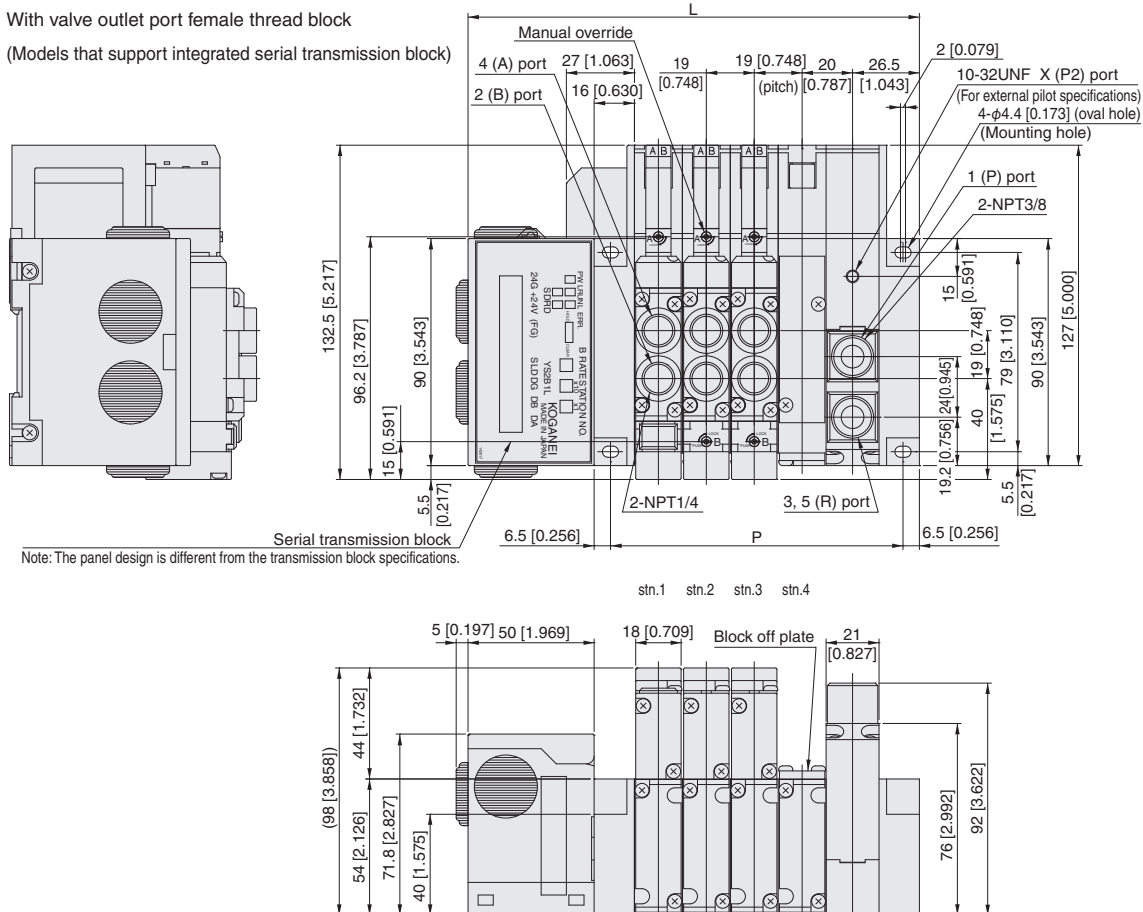

Unit dimensions

Number of units	L	P
2	141 [5.551]	78 [3.071]
3	160 [6.299]	97 [3.819]
4	179 [7.047]	116 [4.567]
5	198 [7.795]	135 [5.315]
6	217 [8.543]	154 [6.063]
7	236 [9.291]	173 [6.811]
8	255 [10.039]	192 [7.559]
9	274 [10.787]	211 [8.307]
10	293 [11.535]	230 [9.055]
11	312 [12.283]	249 [9.803]
12	331 [13.031]	268 [10.551]
13	350 [13.780]	287 [11.299]
14	369 [14.528]	306 [12.047]
15	388 [15.276]	325 [12.795]
16	407 [16.024]	344 [13.543]

Remark: Add 21 [0.827] to the L and P dimensions above when two of the piping blocks are used.

F18M Number of valves **S J M** Pilot specifications (Base piping type)

With manifold outlet port dual use fitting block

(Models that support stand alone transmission block)

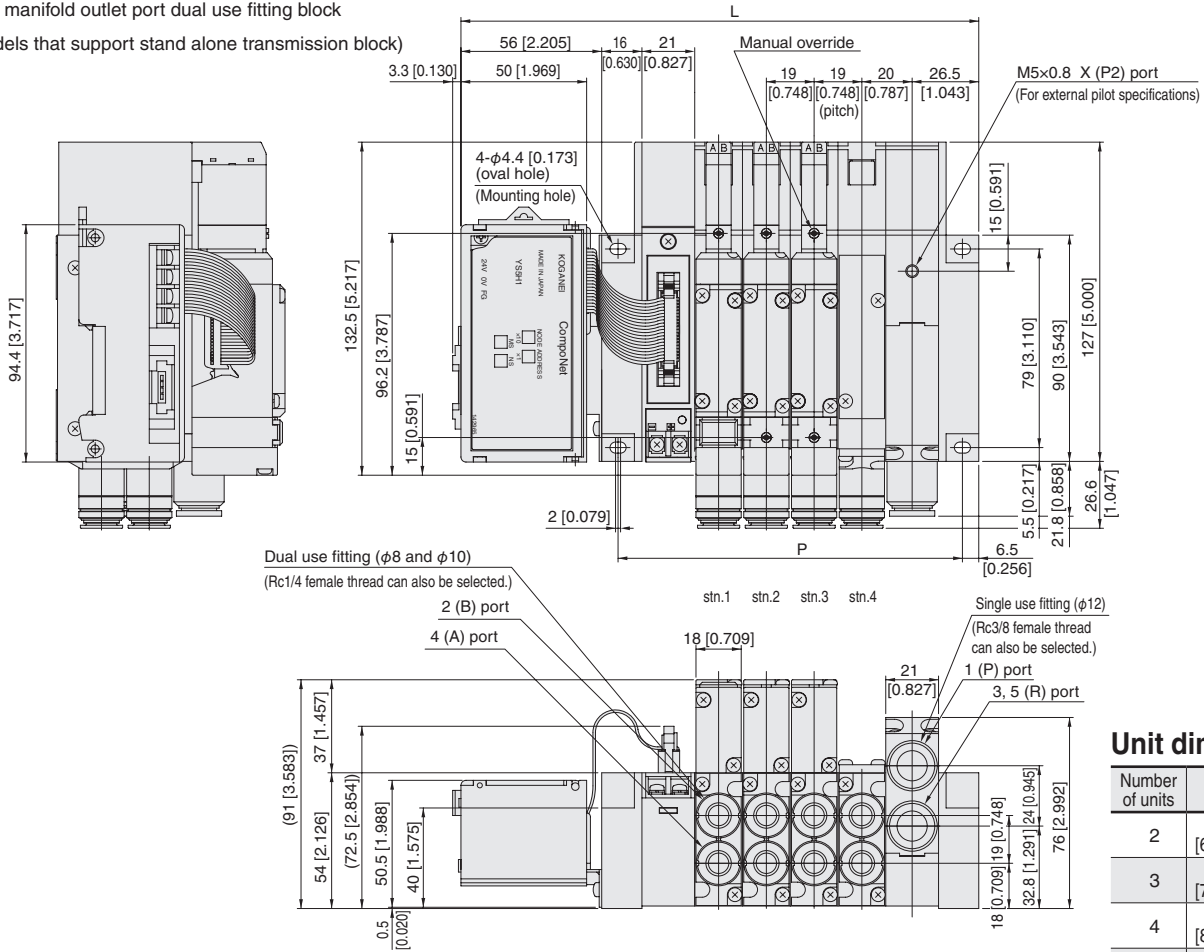

Unit dimensions

Number of units	L	P
2	168 [6.614]	99 [3.898]
3	187 [7.362]	118 [4.646]
4	206 [8.110]	137 [5.394]
5	225 [8.858]	156 [6.142]
6	244 [9.606]	175 [6.890]
7	263 [10.354]	194 [7.638]
8	282 [11.102]	213 [8.386]
9	301 [11.850]	232 [9.134]
10	320 [12.598]	251 [9.882]
11	339 [13.346]	270 [10.630]
12	358 [14.094]	289 [11.378]
13	377 [14.843]	308 [12.126]
14	396 [15.591]	327 [12.874]
15	415 [16.339]	346 [13.622]
16	434 [17.087]	365 [14.370]

* The communication connectors are sold by Omron Corporation. Contact Omron Corporation for details.

Additional Parts (available separately)

● Muffler: **KM-J12** [for both plug-in and non-plug-in]

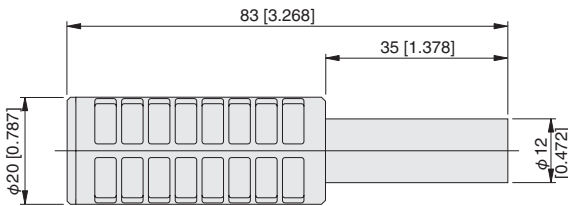

● Muffler: **KM-J8** [for individual exhaust spacer only]

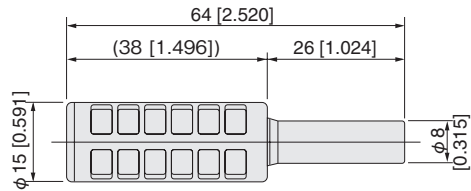

● Muffler: **KM-J10** [for individual exhaust spacer only]

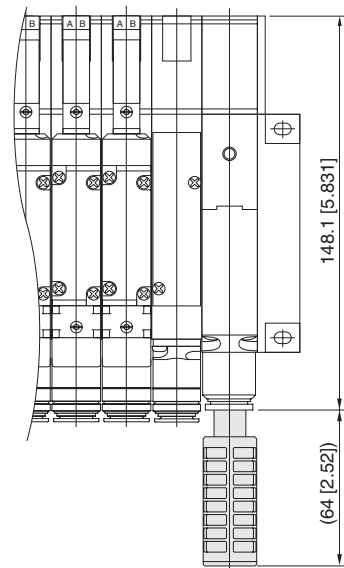
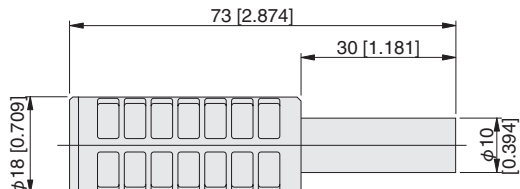

Remark: Add 21 [0.827] to the L and P dimensions above when two of the piping blocks are used.

F18M Number of valves **SHL** Pilot specifications (Base piping type)

With manifold outlet port female thread block

(Models that support stand alone transmission block)

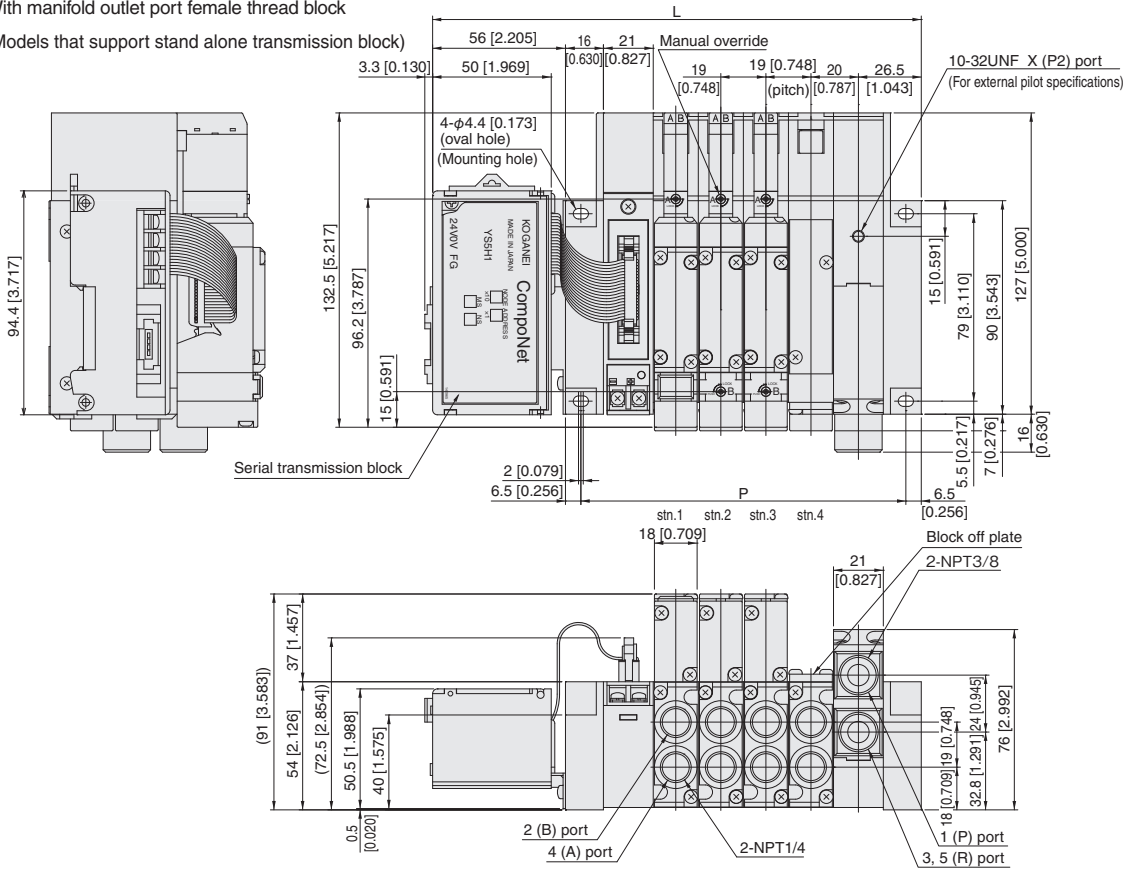

Unit dimensions

Number of units	L	P
2	168 [6.614]	99 [3.898]
3	187 [7.362]	118 [4.646]
4	206 [8.110]	137 [5.394]
5	225 [8.858]	156 [6.142]
6	244 [9.606]	175 [6.890]
7	263 [10.354]	194 [7.638]
8	282 [11.102]	213 [8.386]
9	301 [11.850]	232 [9.134]
10	320 [12.598]	251 [9.882]
11	339 [13.346]	270 [10.630]
12	358 [14.094]	289 [11.378]
13	377 [14.843]	308 [12.126]
14	396 [15.591]	327 [12.874]
15	415 [16.339]	346 [13.622]
16	434 [17.087]	365 [14.370]

Remark: Add 21 [0.827] to the L and P dimensions above when two of the piping blocks are used.

* The communication connectors are sold by Omron Corporation. Contact Omron Corporation for details.

F18M Number of valves **SH** Pilot specifications (Direct piping type)

With valve outlet port female thread block

(Models that support stand alone transmission block)

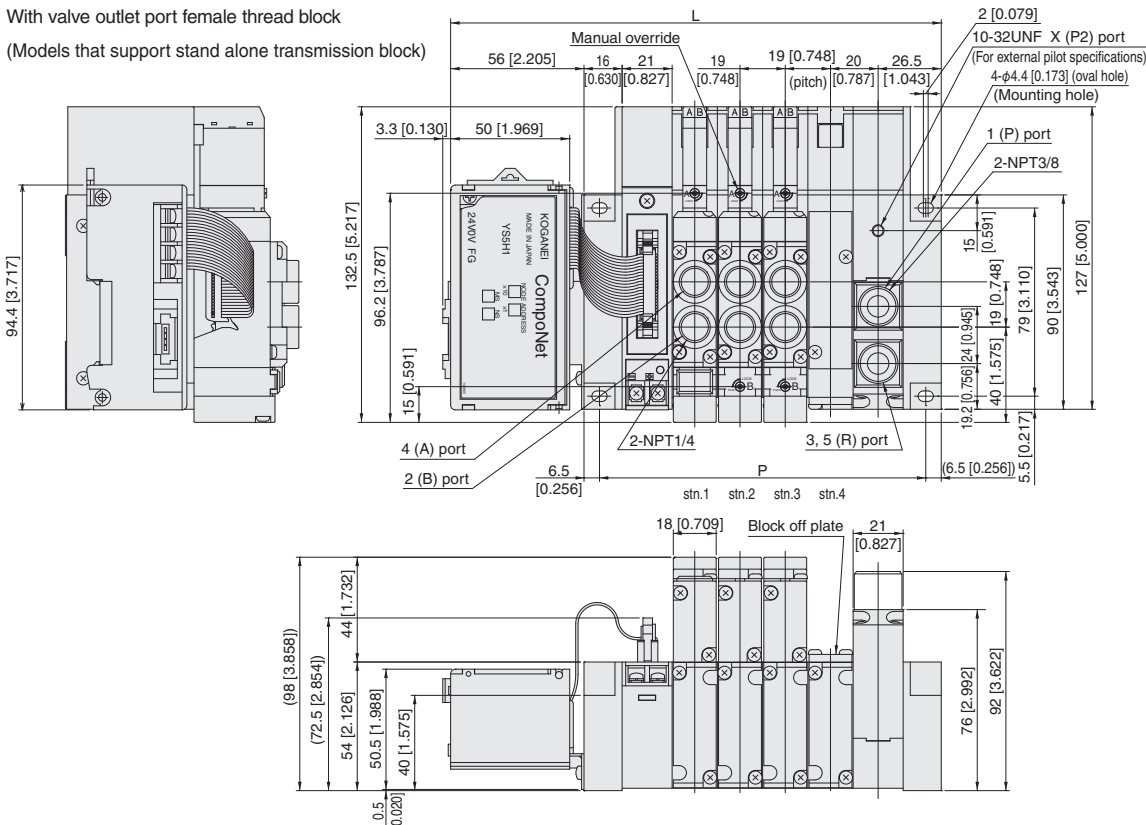

Unit dimensions

Number of units	L	P
2	168 [6.614]	99 [3.898]
3	187 [7.362]	118 [4.646]
4	206 [8.110]	137 [5.394]
5	225 [8.858]	156 [6.142]
6	244 [9.606]	175 [6.890]
7	263 [10.354]	194 [7.638]
8	282 [11.102]	213 [8.386]
9	301 [11.850]	232 [9.134]
10	320 [12.598]	251 [9.882]
11	339 [13.346]	270 [10.630]
12	358 [14.094]	289 [11.378]
13	377 [14.843]	308 [12.126]
14	396 [15.591]	327 [12.874]
15	415 [16.339]	346 [13.622]
16	434 [17.087]	365 [14.370]

Remark: Add 21 [0.827] to the L and P dimensions above when two of the piping blocks are used.

* The communication connectors are sold by Omron Corporation. Contact Omron Corporation for details.

F18 SERIES