

Micro Ejector FME Series

<Vacuum Holding Type>

95% cut in air consumption during conveyance! (According to Koganei test circuit)

<Self Holding Type>

100% cut in solenoid valve electricity consumption during conveyance!

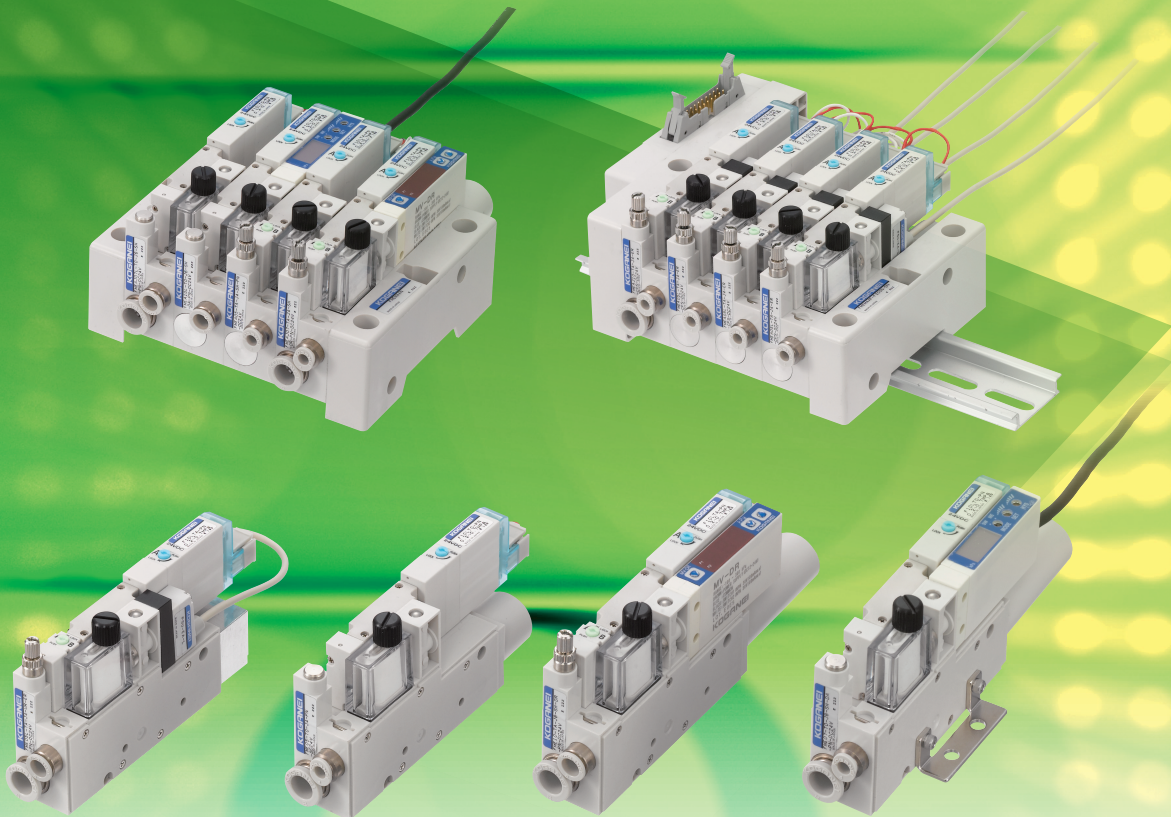

Energy Saving & Silent

20% reduction in air consumption and significant cut in exhaust sound are mutually compatible.

(Compared to our conventional GME series)

Micro Ejector FME Series

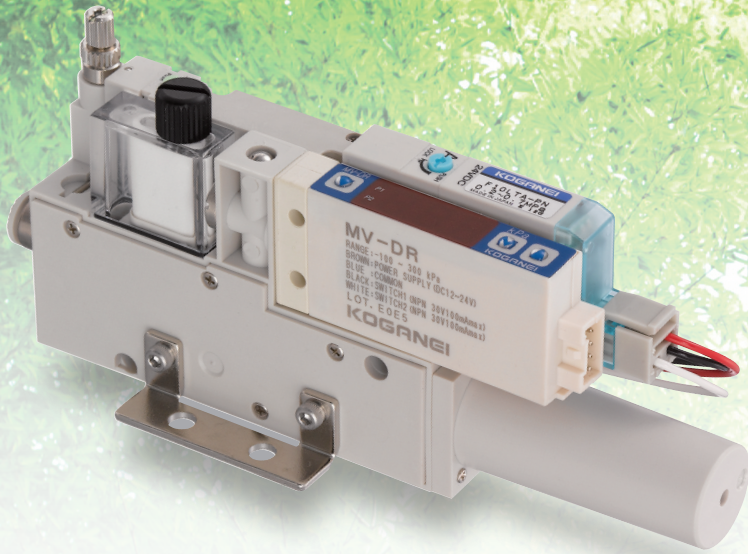

NEW

<Vacuum Holding Type>

Compressed air is not free!!
95% cut in air consumption during conveyance! (According to Koganei test circuit)

<Self Holding Type>

100% cut in solenoid valve electricity consumption during conveyance!
Protect workers and workpieces from equipment electric troubles!

1 Silence-oriented design—Silent exhaust sound

- Conventional exhaust sound can be largely reduced.
- New and innovative design structure that replaces conventional ejectors with loud exhaust noise.

Large reduction



2 Energy saving specification

- 20% reduction of air consumption by new design construction
- Decrease in flow rate reduction of peripheral pneumatic device.

Compared our to conventional GME series

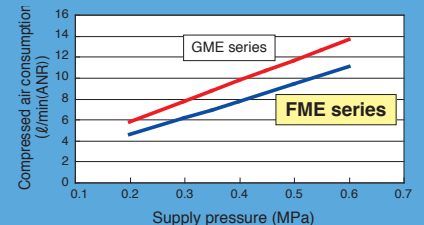

1 MPa = 145 psi. 1 l/min. = 0.0353 ft³/min.

3 Lineup of low pressure specification

- Low-pressure specification of generating vacuum of -88 kPa [-26.0 in.Hg] under supply pressure of 0.36 MPa [52 psi.] is added.
- Responds to low pressure line for energy saving and pressure drop in line ends.

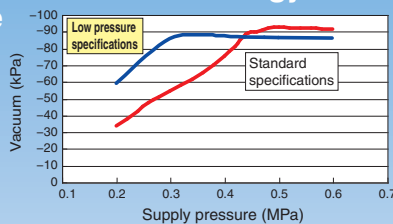

4 Lifting force with higher margin

- The maximum vacuum level is increased from -85 kPa [-25.1 in.Hg] to -90 kPa [-26.6 in.Hg] In the case of the same pad diameter as ever, lifting force is increased.

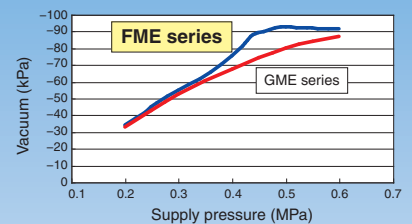

1 MPa = 145 psi. -100 kPa = -29.54 in.Hg

Wide variation

Selection from five types according to your individual needs possible.

In addition to manifold type, plug-in type and serial transmission compatible type are prepared.



Non-plug-in type (without DIN rail)

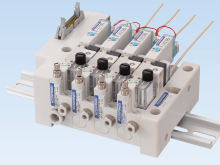

Plug-in type (with DIN rail)

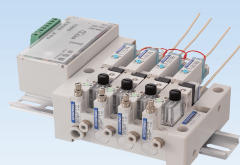

Serial transmission compatible (with DIN rail)



Non-plug-in type (with DIN rail)

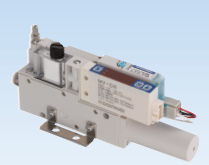

Stand-alone

**A new silent ejector inspiring the forest silence is born.
Exhaust sound that has so far been regarded as noise
is largely reduced!**

(((Energy Saving & Silent)))

**Silence of
industry-leading level**
(When silent-type muffler is used)

**20% reduction in
air consumption**

**Energy-saving-based
ejector is born.**

Noise of our
conventional
ejectors

FME series
Noise when using
standard mufflers

FME series
Noise when using
silent-type muffler
(05 and 07 series)

Indication of noise level range

Noise severity	Noise level	Example of noise severity
It is impossible to have a conversation.	120 dB	Near the engine of aircraft Subway station under severe noisy environment
Difficult to have a conversation	80 dB	Street crossing, along a national road, pachinko parlor, etc.
Need to speak in a louder voice in conversation	70 dB	Theater, bank lobby, noisy office, swiftly flowing mountain stream, etc.
It is possible to have a conversation easily.	60 dB	Restaurant, hotel lobby, within an office, etc.
It is possible to have a conversation even in a small voice.	50 dB	Singing of birds and insects, rustle of the trees, buzz of audience in movie theater, etc.
Silent environment	40 dB or less	Midnight in residential areas in the heart of a city, drizzling rain, etc.

5 Vacuum Holding Type **NEW**

- One-way valve built into ejector! (external appearance same as before)
Energy saving system for vacuum switches cuts 95% in air consumption during conveyance!!! See page 3 for details.

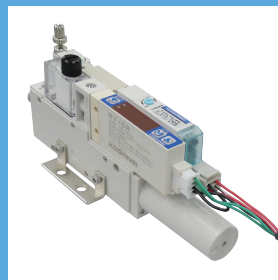

6 Self Holding Type **NEW**

- Double solenoids used in mounted valves! (external appearance same as before)
Continuous energizing to generate vacuum not needed! (Constant vacuum generated by intermittent energization)
Reduce power consumption, prevent workpieces from falling during unexpected power outages, excellent safety measure!! See page 4 for details.



Option

Muffler



Standard (In blank)



Silent type

(-SH)



Fitting exhaust

(-UR)

Multi-Channel, Multi-Sensor Controller MSU sensor head, most suitable for a very small workpiece adsorption detection, is also optionally selectable. The Multi-Channel, Multi-Sensor Controller MSU should be separately prepared. For details about the Multi-Channel, Multi-Sensor Controller, refer to the document contained in the CD-ROM or visit KOGANEI website.



Multi-Channel, Multi-Sensor Controller MSU-□

Electronic vacuum switch



Vacuum switch with digital display
(One switch output variable hysteresis + analog output)

(-DA)



Vacuum switch with digital display
(Compound pressure: Two switch outputs of variable hysteresis type)

(-DR)



MSU vacuum sensor head

(-EA)



MSU compound pressure sensor head

(-ER)

Attention

- ① Exterior color of pressure sensor heads will be changed from white to black. There is no change in performance.
- ② The body color, and the design of the Multi-Channel, Multi-Sensor Controller will be modified.

5 Example of energy saving system using vacuum holding type

With conventional system

[Example of internal circuit]

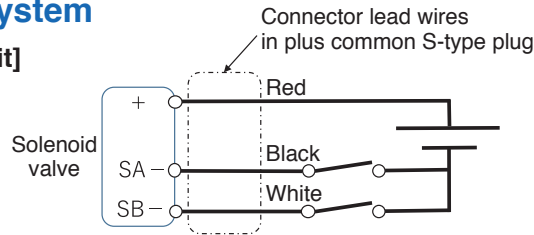

[Image of operations]

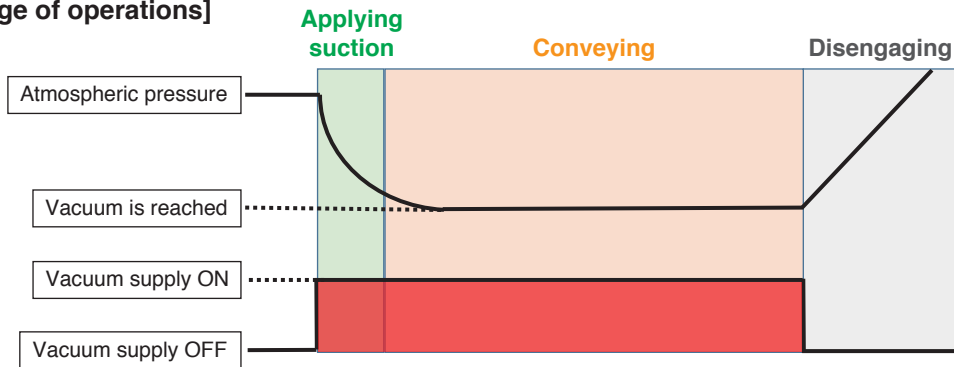

The ejectors must operate continuously while picking up and carrying a workpiece

With the vacuum holding type (vacuum switch + connector lead wire connected type)

95% cut in air consumption during conveyance!

(According to Koganei test circuit)

[Example of internal circuit]

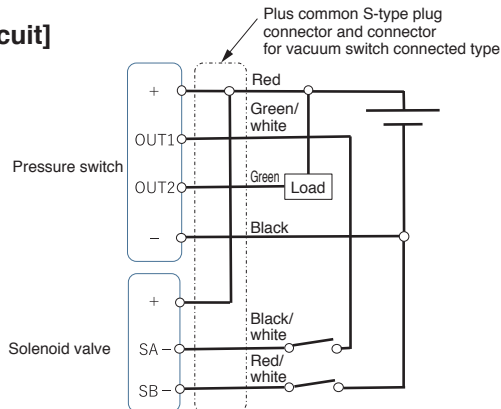

[Order codes: DR(3)-PSK(3)]

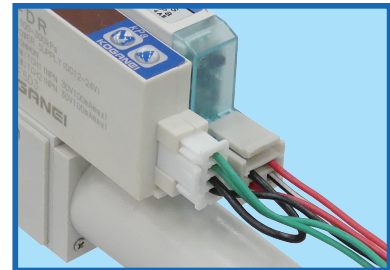

[Image of operations]

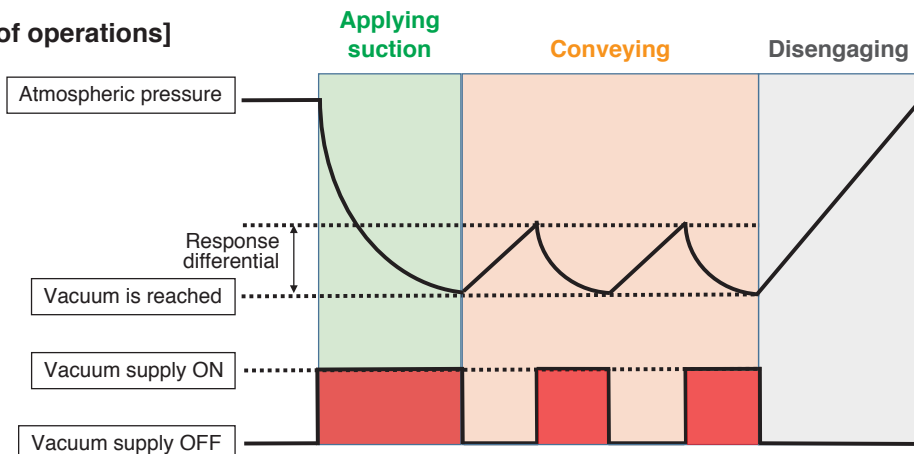

Ejector operations can be stopped because vacuum is retained continuously after suction of workpiece (vacuum leaks during conveyance are detected by vacuum switch so workpiece is prevented from dropping whenever ejector is operating)

6 Vacuum Holding Type

With conventional system

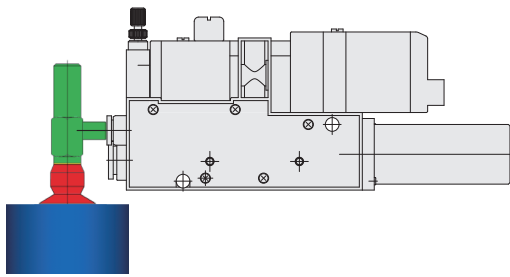

Vacuum valve energization ON

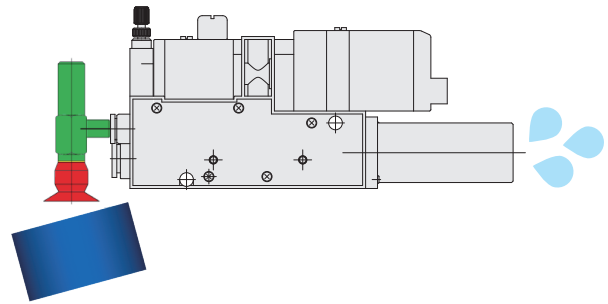

Vacuum supply valve energization ON → OFF

Ejector stops operating if power to vacuum valve is turned off

With self holding type

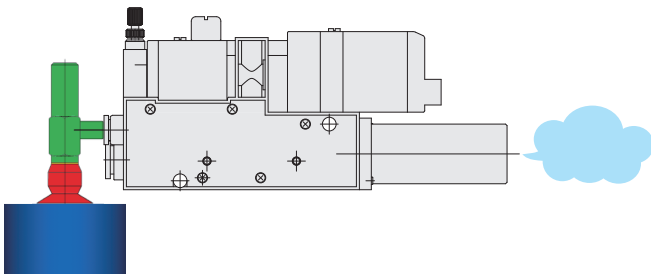

Vacuum valve energization ON

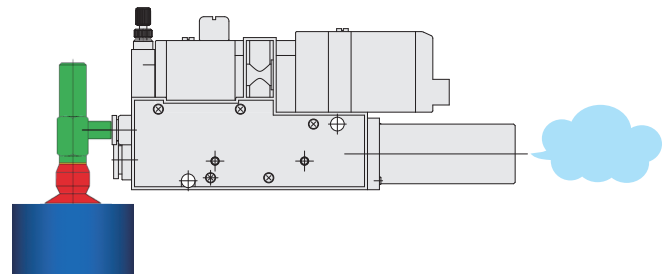

Vacuum supply valve energization ON → OFF

Ejector continues operating even if power to vacuum supply valve is turned off

Perfect for these cases!!



Saves electricity

Need to reduce electric power consumption!

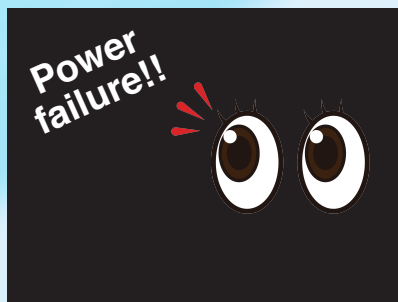



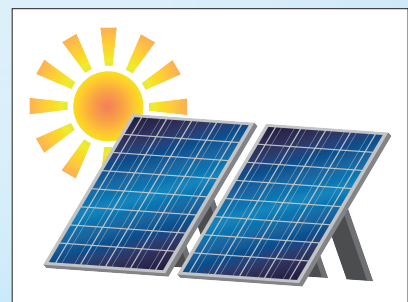

Electric power troubles, such as tripped breakers, are common!



Workpieces are very expensive!

Before selecting and using the products, please read all the Safety Precautions carefully to ensure proper product use. The Safety Precautions described below are to help you use the product safely and correctly, and to prevent injury or damage to you, other people, and assets. Be sure to observe these safety precautions together with the following safety regulations of ISO4414 (General rules and safety requirements for systems and their components) and JIS B 8370 (General rules relating to systems).

The directions are ranked according to degree of potential danger or damage: “DANGER”, “WARNING”, “CAUTION”, and “ATTENTION”.

 DANGER	Indicates situations that can be clearly predicted as dangerous. Death or serious injury may result if the situation is not avoided. It could also result in damage or destruction of assets.
 WARNING	Indicates situations that, while not immediately dangerous, could become dangerous. Death or serious injury may result if the situation is not avoided. It could also result in damage or destruction of assets.
 CAUTION	Indicates situations that, while not immediately dangerous, could become dangerous. Failure to avoid the situation creates the risk of minor or semi-serious injury. It could also result in damage or destruction of assets.
 ATTENTION	While there is little chance of injury, this content refers to points that should be observed for appropriate use of the product.

- This product was designed and manufactured for use in general industrial machinery.
- Before selecting and using the relevant product, be sure to read “Safety Precautions”, “Catalog”, and “Instruction Manual”.
- After reading the instruction manual, catalog, and other documentation, always store them in a location that allows easy availability for reference to users of this product.
- Whenever transferring or lending the product to another person, always attach the catalog, instruction manual, and other information to the product where they are easily visible in order to ensure that the new user can use the product safely and properly.

 **DANGER**

- Do not use the product for the purposes listed below:
 1. Medical equipment related to maintenance or management of human lives or bodies.
 2. Machines or equipment designed for the purpose of moving or transporting people.
 3. Critical safety components in mechanical devices.
This product has not been planned or designed for purposes that require high levels of safety. Using the product in any of the ways described above creates the risk of loss of human life.
- Do not use the product in locations with or near dangerous substances such as flammable or ignitable substances. This product is not explosion-proof. Doing so creates the risk of ignition and fire.
- When mounting the product and workpiece, always make sure they are firmly supported and secured in place. Falling, dropping, or abnormal operation of the product creates the risk of personal injury.
- Persons using a pacemaker or other similar medical devices should maintain a distance of at least 1 meter [3.28 ft] away from the product. Getting too close to the product creates the risk of malfunction of a pacemaker due to the strong magnet built into the product.
- Never attempt to modify the product in any way. Doing so creates the risk of injury, etc due to abnormal operations.
- Never attempt inappropriate disassembly or assembly of the product relating to basic construction, or its performance or functions. Doing so creates the risk of injury, electric shock, fire, etc.
- Do not allow water to splash on the product. Water spraying on the product, washing the product, or using the product under water creates the risk of malfunction, leading to injury, electric shock, fire, etc.
- While the product is in operation, avoid touching it with your hands or otherwise approaching too close. Also, do not attempt to make any adjustments to internal or attached mechanism, or to perform any type of adjustment (manual override, attachment/removal of wiring connectors, adjustment of pressure switch, disconnecting piping tubes or sealed plugs, etc.) while the product is in operation. Product dropping, or abnormal operation of the product may create the risk of personal injury.

 **WARNING**

- Because KOGANEI products are designed for use under a wide variety of conditions, decisions concerning conformance with a particular system should be made upon the careful evaluation of person in charge of system design. Assurances concerning expected system performance and safety are the responsibility of the designer who decides system conformity. Be sure to use the latest catalogs and technical materials to study and evaluate specification details, to consider the possibility of machine breakdown, and to configure a system that ensures fail-safe safety and reliability.

- Do not use the product in excess of its specification ranges. Doing so creates the risk of product breakdown, loss of function, or damage. It could also drastically reduce the product's operating life.
- Before supplying air or electricity to the device and before starting operation, always conduct a safety check of the area where the machine is operating. Unintentional supply of air or electricity creates the risk of electric shock or injury due to contact with moving parts.
- Do not touch terminals or switches while power is turned on. Doing so creates the risk of electric shock and abnormal operation.
- Do not allow the product to be thrown into fire. Doing so creates the risk of explosion, resulting in the release of toxic gasses.
- Do not sit on the product, place your foot on it, or place other objects on it. Doing so creates the risk of injury due to tripping or the product tipping over or dropping, results in product damage and abnormal, erratic or runaway operation.
- Before conducting maintenance, inspection, repair, attachment/removal or replacement of piping, or any other similar procedure, always completely cut off all air supply and confirm that residual pressure inside the product or in piping connected to the product becomes 0. In particular, be aware that residual air will still be in the compressor or storage tank. The actuator may move abruptly if residual air pressure remains inside the piping, causing injury.
- Lock-type manual override should be locked off before starting the normal operation. Failure to do so cause the machine to malfunction.
- Before performing any kind of wiring work, be sure to turn off power. Failure to do so creates the risk of electric shock.
- The solenoid must be properly applied the specified voltage. Application of incorrect voltage may prevent the functions from working properly and cause the product to be damaged or burned out.
- Do not allow lead wires and other cords to become damaged. Allowing a cord to become damaged, bent excessively, pulled, rolled up, or squeezed between two objects creates the risk of current leaks or defective continuity that can lead to fire, electric shock, or abnormal operation.
- Never insert or pull out the connectors while power is supplied. And, never apply unnecessary force to the connectors. Doing so creates the risk of personal injury, device damage, and electric shock due to abnormal machine operation.
- Always check the catalog and other reference materials for correct product wiring and piping. Improper wiring and piping creates the risk of damage to and abnormal operation of the product, etc.
- Use safety circuits or design a system that prevents damage to machinery and personal injury when the machine is shut down due to an emergency stop or electrical power failure.
- Be sure to perform heat radiation countermeasure so that ambient temperature of a solenoid valve (or temperature within the control box if it is used) is always within the specified temperature range.
- If the product has not been used for over 30 days, it is possible that the contacting parts may have stuck, leading to delay or sudden movement of the machine operation, thereby causing injury. Be sure to perform trial

Safety Precautions

operation once every 30 days in minimum to check whether the machine works properly.

- Do not use the solenoid valves and the wiring for controlling them in a location near power lines with high current flowing and in a location where high magnetic field and surges are generating. This may cause unintentional operation of the machine.
- Never use the product in direct sunshine-suffered location like beach, near mercury lamp, and near a product likely to produce ozone. Deterioration of rubber parts caused by ozone may reduce the performance and function or stop the function.
- Do not use any type of medium that is not specifically stipulated in the specifications. Using a non-specified medium could lead to loss of function in a short period of time, sudden degradation of performance, and a reduced operating life.
- When the machine has been idle for over 48 hours or is in first operation after storage, it is possible that the contacting parts may have become stuck, leading to operation delays or sudden movements. In initial operation, be sure to perform trial operation to check whether the machine works properly.
- After completing wiring work, check to make sure that all connections are correct before turning on power.
- Do not use in locations that are subject to direct sunlight (ultraviolet rays); locations with high humidity and temperature, dust, salt, or iron particles; or in locations with fluids and/or ambient atmosphere that include organic solvents, phosphate ester type hydraulic oil, sulfur dioxide, chlorine gas, acids, etc. It could lead to early shutdown of some functions, a sudden degradation of performance, and a reduced operating life. For details on part materials, refer to the materials in major parts.
- If you perform continuous energizing for long time, consult us.

CAUTION

- When mounting the product, leave room for adequate working space around it. Failure to do so will make it more difficult to conduct daily inspections or maintenance, which could eventually lead to system shutdown or damage to the product.
- When moving or installing products heavy in weight, be sure to secure the safety of workers by supporting them with lift or support tool or using the force of multiple people.
- Leakage current occurred in the control circuit may cause unintended behavior of the products. Be sure to take a countermeasure against the leakage current to the control circuit so that the leakage current may not exceed the allowable leakage current value specified for respective products.
- Use in extremely dry air under temperatures that exceed -20°C [-4°F] may affect the quality of the lubricating oil used. This creates the risk of degraded performance, loss of function, or other problems.
- Do not scratch, dent, or deform the product by climbing on it, using it as a scaffold, or placing objects on top of it. Doing so creates the risk of damage to or breakage of the product, resulting in operational shutdown or degraded performance.
- Always post an "operations in progress" sign for installations, adjustments, or other operations, to avoid unintentional supplying of air or electrical power, etc. Unintended power or air supply can cause electric shock and sudden operation, creating the risk of personal injury.
- The micro ejector and pressure switch should not be used in a location where high current or magnetic field is generating. This may cause the machine to malfunction.
- Some air does leak from valves. For applications that retain vacuum pressures, you need a design that takes into consideration necessary capacities and retention times.

ATTENTION

- Whenever considering use of this product in situations or environments not specifically noted in the catalog or instruction manual, or in applications where safety is an important requirement such as in aircraft facilities, combustion equipment, leisure equipment, safety equipment, and other places where human life or assets may be greatly affected, take adequate safety precautions such as allowing plenty of margin for ratings and performance, or fail-safe measures. Be sure to contact KOGANEI before use in such applications.
- Always check the catalog and other reference materials for product wiring and piping.
- Moving parts of machine and devices should be isolated with protection covers so as not to be directly contacted by human body.

- Never configure the control that may cause a work to drop when in power outage. Be sure to configure the work-drop prevention control for the case of power outage or emergency stop of the machine.
- When handling the product, wear protective gloves, safety glasses, safety shoes etc., as required.
- When the product can no longer be used or is no longer necessary, dispose of it appropriately as industrial waste.
- Pneumatic equipment can exhibit degraded performance and function over its operating life. Always conduct daily inspections of the pneumatic equipment, and confirm that all requisite system functions are satisfied, to prevent accidents from happening.
- For inquiries about the product, consult your nearest KOGANEI sales office or KOGANEI overseas department. The addresses and telephone numbers are shown on the back cover of this catalog.

Others

- Always observe the following items. KOGANEI shall not be held responsible for any problems that occur as a result of these items not being properly observed.
 1. When using this product in a pneumatic system, always use genuine KOGANEI parts or compatible products (recommended products).
When conducting maintenance and repairs, always use genuine KOGANEI parts or compatible products (recommended products). Such working should be performed by technicians who have a knowledge of pneumatic system.
Always observe the prescribed methods and procedures.
 2. Never attempt inappropriate disassembly or assembly of the product relating to basic construction, or its performance or functions.

KOGANEI shall not be held responsible for any problems that occur as a result of these items not being properly observed.

Warranty and General Disclaimer

1. Warranty Period

The warranty period for Koganei products is 1 year from the date of delivery.

*However, some products have a 2-year warranty; contact your nearest Koganei sales office or the Koganei overseas department for details.

2. Scope of Warranty and General Disclaimer

- (1) When a product purchased from Koganei or from an authorized Koganei distributor or agent malfunctions during the warranty period in a way that is attributable to Koganei's responsibility, Koganei will repair or replace the product free of charge. Even if a product is still within the warranty period, its durability is determined by its operation cycles and other factors. Contact your nearest Koganei sales office or the Koganei overseas department for details.
- (2) The Koganei product warranty covers individual products. Therefore, Koganei is not responsible for incidental losses (repair of this product, various expenses required for replacement, etc.) caused by breakdown, loss of function, or loss of performance of Koganei products.
- (3) Koganei is not responsible for any losses or for any damages to other machinery caused by breakdown, loss of function, or loss of performance of Koganei products.
- (4) Koganei is not responsible for any losses due to use or storage of the product in a way that is outside of the product specifications prescribed in Koganei catalogs and instruction manuals, and/or due to actions that violate the mounting, installation, adjustment, maintenance or other safety precautions.
- (5) Koganei is not responsible for any losses caused by breakdown of the product due to factors outside the responsibility of Koganei, including but not limited to fire, natural disaster, the actions of third parties, and intentional actions or errors by the purchaser.

Handling Instructions and Precautions



General precautions

Installation

- Any posture is available in installation, but be careful so that strong impact or vibration may not be directly applied to the machine.
- Avoid using the product under the following locations and environment which may cause the failure in the valve. If you are compelled to use it, be sure to take a sufficient protection countermeasure using such as a cover.
 - Location where water drop and oil drop may directly fall on the valve
 - Environment which may cause dew to be formed in the valve
 - Location where machining chips and dust may directly fall on the valve
 - Location which contains salt content, corrosive gas, or conductive powder
- Before piping into a micro ejector, be sure to fully perform flushing within the piping (blowing of compressed air). Entering of machining chips, seal tape, or rust produced during piping work may cause air leak in the valve or deteriorate the performance of a micro ejector.
- For air used in the micro ejector, be sure to use clean air which does not contain degraded compressor oil. Install an air filter (nominal filtration rating is 40 μ m or less) near the micro ejector and remove sedimentation and dust. If the compressed air is especially oily, be sure to use a mist filter. And, perform draining the filter periodically.
- The air supplied to the micro ejector should be pressure-adjusted by a regulator. If the piping to the micro ejector is long, be sure to set the pressure at higher level. When using an air supply valve, be sure to use a valve whose effective area is three or more times larger the nozzle area of micro ejector.
- A single vacuum pad should be used for each micro ejector. Using two or more vacuum pads may cause lifting error and also cause the time to reach the set vacuum level to be prolonged.
- Periodically replace a filter (order code: **FME-F**) included in the micro ejector unit as standard.
- For pressure medium, do not use medium containing corrosive gasses and liquids.
- Do not apply pressure exceeding the proof pressure to the vacuum switch and pressure sensor.
- Do not pull or bend the lead wires excessively. And, when handling the product, be sure to hold the body and be careful not to apply excessive force to the power cord etc.
- For installing a single micro ejector, an optional mounting bracket (**PSU-BR**) is available (tightening torque: 32 N·cm [2.83 in·lbf]).
For installing the main unit directly, use M4 screws (tightening torque: 50 to 60 N·cm [4.43 to 5.31 in·lbf]).
- The area surrounding the exhaust port should be kept enough space. Failure to do so, it may cause resonance in exhaust air, thereby increasing the noise or deteriorating the performance of micro ejector.
- When increasing or decreasing the manifold or replacing parts for maintenance, be sure to perform the tightening with a specified tightening torque.

Wiring

After completing the wiring, be sure to check whether the wire is correctly connected.



Solenoid

Internal circuit

●FME□□□-TA

Voltage specifications	Internal circuit
12VDC	<p>(Inside of connector)</p>
24VDC	<p>(Inside of connector)</p>



- Do not perform a megger test between pins.
- Leakage current in the circuit may cause a malfunction such as a failure to return the solenoid valve. Be sure to use the products within the allowable circuit leakage current described in the electric specifications on page 9. If leakage current exceeds the allowance due to circuit conditions or other reasons, consult your nearest KOGANEI sales office.
- In the case of a double solenoid type, avoid simultaneous energizing to both solenoids.
- The valve model **FME□□□-T0** has one solenoid.

Wire connection method

1. Attachment/removal of plug connector

When attaching a connector, insert the connector onto the pin while pinching it with fingers and push it until the lever's claw latches on the protruded section of the housing.

To remove the connector, pinch the lever and connector together and pull out them after certainly disengaging the lever's claw from the protruded section of the housing.

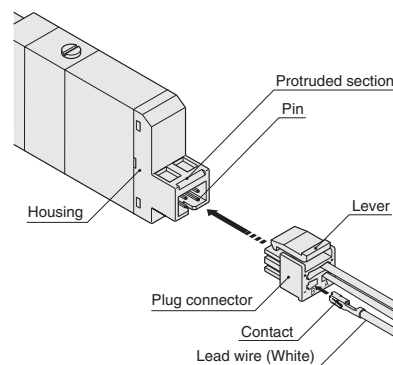

- When removing the connector, pull it out after checking that the lever's claw is surely disengaged from the protruded section. Pulling out the connector with the claw caught in the protruded section may damage the housing.
- FME□□□-TA (-TK, -T2)** employs three lead wires. **FME□□□-T0** employs two lead wires.

2. Attachment/removal of plug connector and contacts

● When attaching

When inserting the contact-attached lead wire into □ hole of the plug connector, the contact's hook latches on the plug connector and is secured. At that time, be sure to check that the lead wire is not removed when pulling the wire lightly (see the figure below).

● When removing

To remove the lead wire, insert a pointed tool (like a small screwdriver) into the rectangular hole on the side surface of the plug connector to push the hook, and then pull the lead wire. When re-using the contact, restore the hook back so that they spread outward.

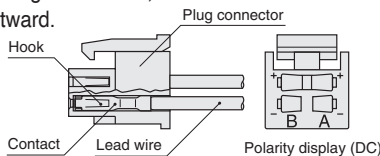

3. Common terminal and short bar

A short bar is attached to the plug connector so that the wire connection of solenoid A (SA) and B (SB) are positive common. Do not remove the short bar.

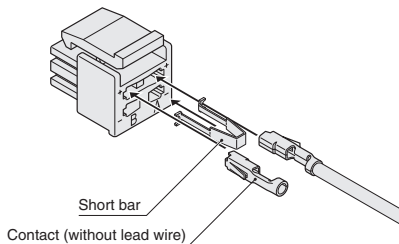

Manual override

Manual override (used for both Lock and Non-lock)

Use a small screwdriver to push lightly against the manual override button, and then turn it by 90 degrees in the clockwise direction to lock. When turning the manual override from the locked state by 90 degrees in counterclockwise direction, the manual override returns to original position by spring and the lock is released.

If the manual override is not turned, it is possible to perform the same operation as non-lock type.

- Note**
1. The manual override should be locked off before starting the normal operation.
 2. The manual override should not be operated with an extremely pointed tool like a needle. It may damage the override.
 3. Turning the manual override too much may damage the override, so be careful in such operation.
 4. When operating the manual override for solenoid valve in the maintenance etc, be sure to check that the manual override for solenoid valve is in original position and the main valve is in required switching position before restarting the operation.

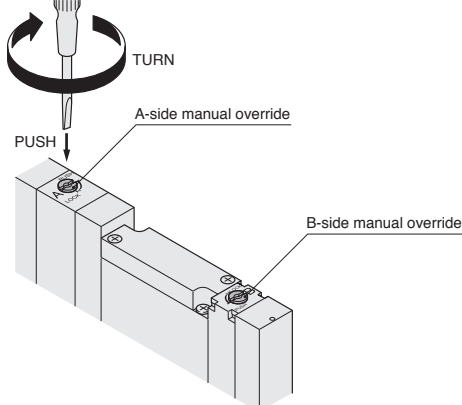

Vacuum breaking

Adjustment of vacuum breaking flow rate

Turning the vacuum breaking flow rate adjusting needle in clockwise direction will reduce the breaking flow rate, and turning the needle in counterclockwise direction will increase the breaking flow rate.

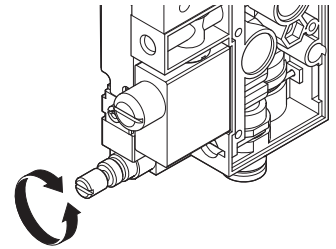

Piping

1. Connect air supply line to the compressed air supply port, and a vacuum pad, etc. to the vacuum generation port.
2. Use fittings and tubes that does not reduce inner diameter. A small inner diameter can result in degradation of performance, including flow rate and pressure shortages, insufficient vacuum, or longer periods of time before the vacuum level is reached. In the case of collective exhaust, increased exhaust resistance may cause insufficient performance due to vacuum performance degradation and exhaust air flowing into other stations. Refer to the following countermeasures.
 - Avoid a location that affects exhaust, such as a wall.
 - Enlarge the fitting size and the pipe diameter and shorten the length of the piping as possible.
 If the above measures do not improve the performance, consult your nearest KOGANEI sales office.
3. Avoid use of coil tubing and other spiral tubing. Also, avoid use of elbow fittings, etc. between the micro ejector and vacuum pad, and use piping that is as straight as possible.
4. In manifolds with many stations, where a large number of micro ejectors are operating simultaneously, or where the operation frequency is very high, use the station with a supply port of quick fitting for $\phi 8$ or 1/4 in. tube (AJ, 1AJ, AJ1/4, 1AJ1/4) and supply air using P ports.

Tube

1. **Attaching and detaching tubes**
When an installing tube, insert an applicable-sized tube all the way up to the tube stopper and check the installation by gently pulling the tube. When removing the tube, push the tube up to the tube stopper first, and then pull out the tube, pushing the release ring evenly at the same time.
2. **Both nylon tube and urethane tube are supported.**
Tube outside diameter precision should be within ± 0.1 mm [0.004 in.] (nominal) for nylon tube and within ± 0.15 mm [0.006 in.] (nominal) for urethane tube. Use tube with ovality (difference between major axis and minor axis) within 0.2 mm [0.008 in.]. (KOGANEI tube is recommended.)
Use of tubing that is not a KOGANEI genuine product or a compatible product (recommended product) may result in tube disconnection, air leakage, or other problems. Be sure to check on tubing before building a pneumatic system.



1. Do not use extremely soft tubing, which causes a severe drop in pull-out strength.
2. Be sure to use tubing whose exterior is undamaged. If tubing becomes damaged after repeated use, cut off the damaged portion.
3. Do not allow tubing to become severely bent or twisted in the vicinity of fittings. Such a condition creates the risk of air leakage. The table below shows minimum bending radius guidelines for nylon tube and urethane tube.
4. When attaching or detaching tube, be sure to stop the air supply. Also, make sure that air in the manifold has been completely exhausted before attaching or detaching tubing.

Tube size	Minimum bending radius	
	Nylon tube	Urethane tube
$\phi 4$ [0.157]	20 [0.8]	10 [0.4]
$\phi 6$ [0.236]	30 [1.2]	15 [0.6]
$\phi 8$ [0.315]	50 [2.0]	20 [0.8]

Handling Instructions and Precautions



Micro ejector

Device configuration

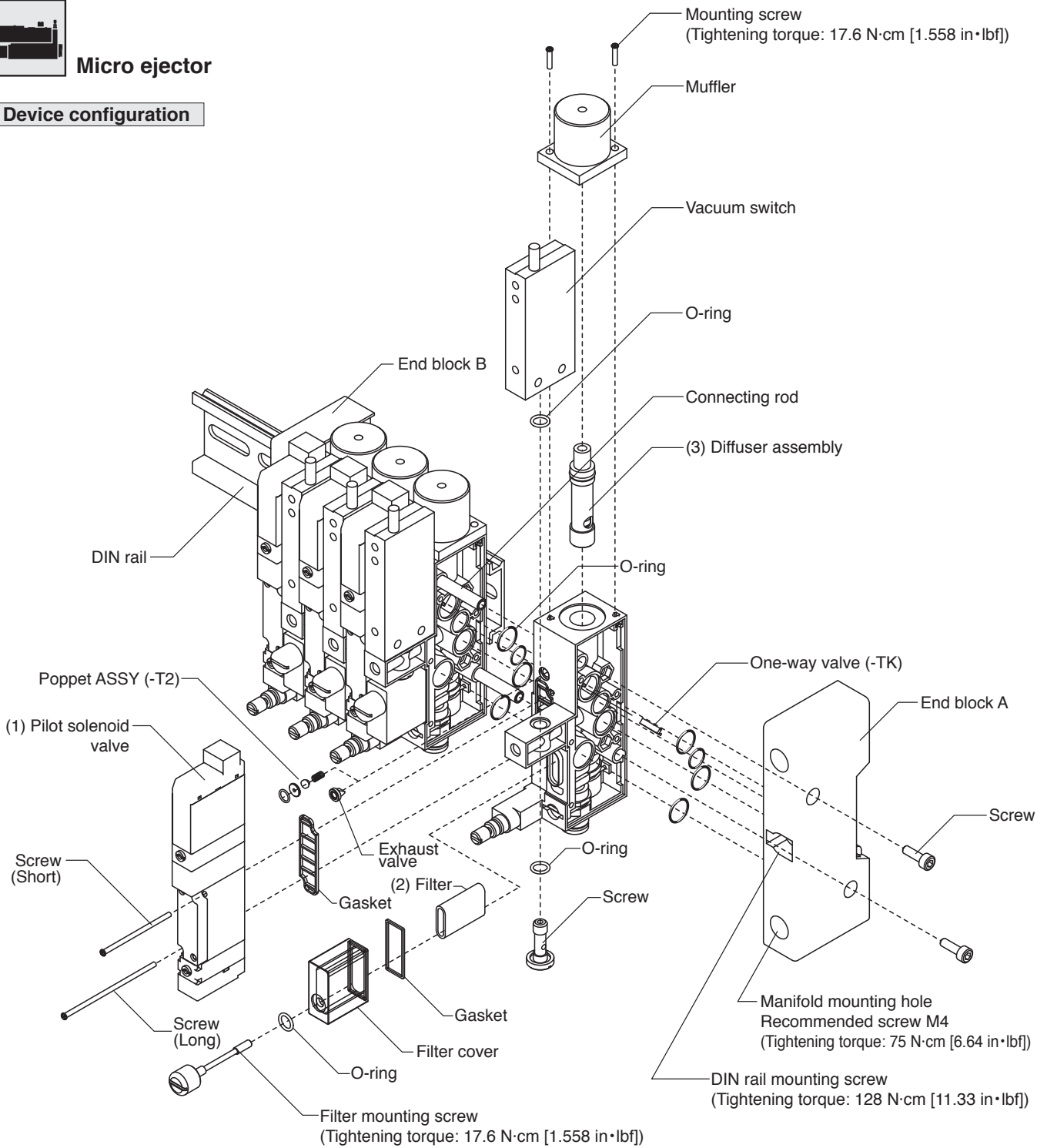

Maintenance parts

If vacuum level decreases or air leakage from the valve happens, replacement of maintenance parts is recommended. For more information on maintenance, refer to the instruction manual.

No.	Name	Tightening torque	Order code
(1)	Pilot solenoid valve	17.6 N·cm [1.558 in·lbf]	FME □□□-T0 : F10T0-A1-PN DC12V:
		17.6 N·cm [1.558 in·lbf]	: F10LT0-A1-PN DC24V
		17.6 N·cm [1.558 in·lbf]	FME □□□-TA(-TK) : F10TA-A1-PN DC12V
		17.6 N·cm [1.558 in·lbf]	: F10LTA-A1-PN DC24V
		17.6 N·cm [1.558 in·lbf]	FME □□□-T2 : F10T2-A1-PN-1068W DC12V
		17.6 N·cm [1.558 in·lbf]	: F10LT2-A1-PN-1068W DC24V
(2)	Filter	17.6 N·cm [1.558 in·lbf]	FME-F (5 pcs. per bag)
(3)	Diffuser assembly	—	Consult your nearest KOGANEI sales office.

Manifold assembly

Screw the two connecting rods all the way into end block B, and then assemble the ejector bodies into the connecting rods in any order. Finally, place in end block A, and tighten hexagon socket screws to secure it in place.

Be sure to place both end blocks on a flat surface not to twist the whole manifold when tightening rods and screws. (Tightening torque 100 N·cm [8.85 in·lbf])

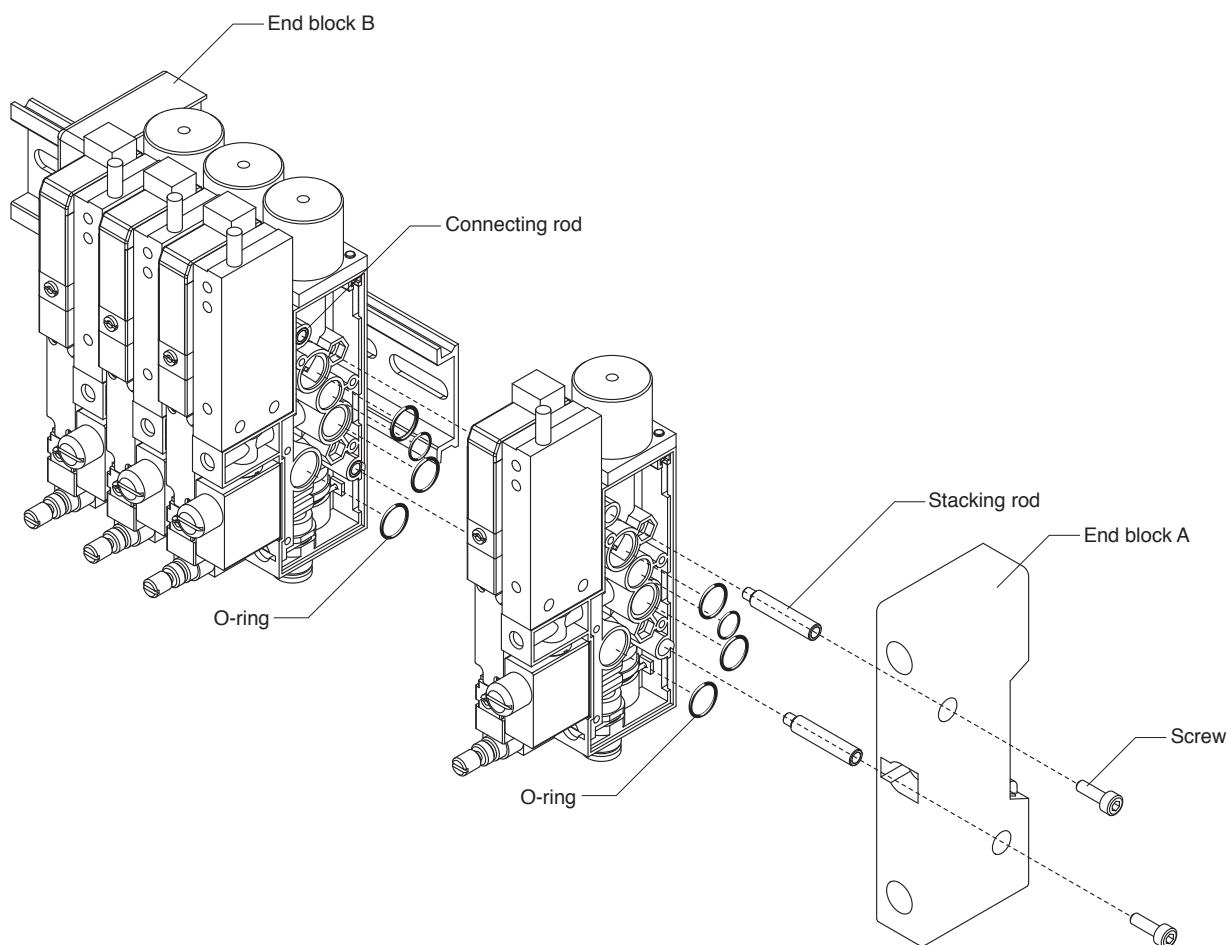

Additional stacking method (FMEC)

Loosen two hexagon socket screws, and remove end block A. Screw the two supplied stacking rods into the connecting rods. At this time, check to see whether the connecting rods attached to end block B are secured. Place the O-ring as shown above to install the ejector bodies and the end blocks. (Tightening torque 100 N·cm [8.85 in·lbf])

Note For adding units, assemble the additional stacking unit (FMEC) according to the illustration above. Note that the number of combined units cannot be reduced. Consult your nearest KOGANEI sales office when requiring unit reduction. (A special connecting rod is required.)

Micro Ejector

FME□05·FME□07·FME□10

Specifications

Basic model		FME□05	FME□05L	FME□07	FME□07L	FME□10	FME□10L
Media		Air ^{*1}					
Operating pressure range	MPa [psi.]	0.2 to 0.6 [29 to 87], 0.3 to 0.6 [44 to 87] (-T2)					
Proof pressure	MPa [psi.]	0.9 [131]					
Operating temperature range (ambient and media) ^{*2}	°C [°F]	5 to 50 [41 to 122]					
Nozzle diameter	mm [in.]	0.5 [0.020]	0.5 [0.020]	0.7 [0.028]	0.7 [0.028]	1.0 [0.039]	1.0 [0.039]
Vacuum ^{*3}	kPa [in.Hg]	-90 [-26.6]	-88 [-26.0]	-90 [-26.6]	-88 [-26.0]	-90 [-26.6]	-88 [-26.0]
Vacuum flow rate ^{*3}	ℓ /min [ft ³ /min] (ANR)	5.5 [0.19] (5.3[0.19])	5 [0.18] (4.8[0.17])	10 [0.35] (9.6[0.34])	8 [0.28]	19 [0.67] (18[0.64])	17 [0.60] (16[0.57])
Compressed air consumption ^{*3}	ℓ /min [ft ³ /min] (ANR)	10 [0.35]	14.5[]	18 [0.64]	19 [0.67]	38 [1.34]	36 [1.27]
Lubrication		Prohibited					
Filtration	μm	30					
Piping size	Vacuum generation port	Quick fitting for φ4, φ6, 1/8 in., 1/4 in. tube					
	Compressed air supply port	Quick fitting for φ8 or 1/4 in. tube					
Mounting direction		Any					
Main valve specifications	Response time ^{*4}	A/B ms		15/15			
	Operation method	Internal pilot type					
	Valve function	Normally closed (NC standard)					
Shock resistance ^{*5}	m/s ² [G]	294.2 [30], 245 [25] (-T2)					

*1: Assumes use of pure air from which oil mist and dust, etc. have been removed.

*2: Take heat radiation measures to ensure that the ambient temperature (or when used in a control box, the inside temperature of the box) always remains within the specified temperature range.

Moreover, for long-term continuous energizing, consult us.

*3: As for the standard products, the nominal value is when air pressure is 0.5 MPa [73 psi.]. As for L type (low pressure type), the nominal value is when air pressure is 0.36 MPa [52 psi.]. Values in () are for -TK.

*4: The period from when a solenoid valve for controlling air is energized until generation of negative pressure is A, while the period from when a solenoid valve for controlling vacuum breaking air is energized until a generation of vacuum breaking is B.

*5: The value is shock resistance values in the valve stem axis direction. The shock resistance values are the values where breaking of vacuum occurs.

Specifications for solenoid valve

Model	Functions	Specifications for solenoid valve	Voltage	Mounted solenoid valve
FME□□□-T0	—	Air supply control valve (NC)	12VDC	F10T0-A1-PN DC12V
			24VDC	F10LT0-A1-PN DC24V
FME□□□-TA	—	Air supply control valve (NC) Vacuum breaker air control valve (NC)	12VDC	F10TA-A1-PN DC12V
			24VDC	F10LTA-A1-PN DC24V
FME□□□-TK	With vacuum holding function	Air supply control valve (NC) Vacuum breaker air control valve (NC)	12VDC	F10TA-A1-PN DC12V
			24VDC	F10LTA-A1-PN DC24V
FME□□□-T2	With self holding function	Air supply control valve (NC) Vacuum breaker air control valve (NC)	12VDC	F10T2-A1-PN-1068W DC12V
			24VDC	F10LT2-A1-PN-1068W DC24V

Electric Specifications

Mounted solenoid valve model		F10T0	F10LT0	F10TA(T2)	F10LTA(T2)
Rated voltage		12VDC	24VDC	12VDC	24VDC
Operating voltage range	V	10.8~13.2 (12±10%)	21.6~26.4 (24±10%)	10.8~13.2 (12±10%)	21.6~26.4 (24±10%)
Current value (when rated voltage applied)	mA (r-m-s)	33	17/4.2 (on starting/holding)	33	17/4.2 (on starting/holding)
Consumption wattage	W	0.4	0.4/0.1	0.4	0.4/0.1
Allowable circuit leakage current	mA	2.0	1.0	2.0	1.0
Period of starting conditions	ms	—	70	—	70
Insulation resistance	MΩ	100 minimum			
Color of lead wire		Red (+), black (-)		Red (+), black (-), white (-)	
Color of LED indicator		Red		14(SA) red, 12 (SB) green	
Surge suppression (standard)		Surge absorption transistor	Flywheel diode	Surge absorption transistor	Flywheel diode

Electronic Vacuum Switch Specifications

Model name		-DR	-DR3 (MV-DR)	-DA (MV-DA)	
Item	Type	Two switch outputs (variable hysteresis)		One switch output (variable hysteresis with analog output)	
General	Pressure range	300 to -100 kPa [44 psi. to -29.5 in.Hg]		0 to -100 kPa [0 to -29.5 in.Hg]	
	Pressure resistance	600 kPa [87 psi.]		200 kPa [29 psi.]	
	Operating temperature	-10 to 60°C [14 to 140°F]			
	Operating ambient humidity	35 to 85% RH			
	Media	Air or non-corrosive gas			
	Insulation resistance	100 MΩ MIN. (at 500VDC megger)			
	Cable	1500 mm [59 in.] lead wire with connector	3000 mm [118 in.] lead wire with connector	Shielded 4 leads × 1500 mm [59 in.]	
Power	Power supply voltage	fs12 to 24VDC ±10%			
	Consumption current	35 mA MAX. (at 24V when output is ON)			
Switch output	Number of outputs	2		1	
	Output type	NPN open collector			
	Pressure setting method	Variable with use of a trimmer			
	Pressure setting range	0 to 100% of rated pressure			
	Output display	When ON, operation indicator (LED) lights up			
	Accuracy	±3% F.S. MAX. (0 to 50°C [32 to 122 °F], reference point of 25°C [77 °F])			
	Hysteresis	0 to 30 counts variable		Approximately 0 to 15% F.S. variable	
	Switching capacity	DC30V, 80mA, MAX.			
Analog output	Output voltage			1 to 5 V	
	Zero-point voltage (V ^{ZERO})			1 to 5 V	
	Span voltage (V ^{SPAN})			4±0.1V	
	Temperature characteristics	V ^{ZERO}	-		±0.1% F.S./°C [±0.056% F.S./°F] (0 to 50°C [32 to 122 °F], reference point of 25°C [77 °F])
		V ^{SPAN}			±0.1% F.S./°C [±0.056% F.S./°F] (0 to 50°C [32 to 122 °F], reference point of 25°C [77 °F])
	Output current			1 mA MAX (Load resistance 5 kΩ or more)	
Linearity/Hysteresis			±0.5% F.S. MAX.		
Environmental characteristic	Vibration resistance	98.1 m/s ² [10 G]			
	Shock resistance	196 m/s ² [20 G]			

Pressure sensor ※

● Sensor head/Compound pressure sensor head

Item	Negative pressure	Compound pressure	
Model	-EA	-ER	
Cable	Oil and flex resistance PVC 26AWG × 3-core 3000 mm [118 in.]		
Media	Air or non-corrosive gas		
Power supply	Voltage	24 VDC ±10%	
	Consumption current	6 mA MAX.	
Analog output	Output voltage	1 to 5 V	
	Zero-point voltage (V _{zero})	1.00 ±0.05	3.75 ±0.05
	Span voltage	4.00 ±0.07 (reference value)	
	Temperature characteristics	V _{zero} : within ±30 mV; span: within ±2% F.S.	
	Output current	1 mA max. (load resistance of 5 kΩ or more)	
General	Operating pressure range kPa	-101.3 to 0	-100.0 to 220.0
	Proof pressure kPa	900	
	Operating temperature range	0 to 50°C; when stored: -20 to 80°C (when stored: humidity of less than 65% RH, atmospheric pressure)	
	Operating humidity range	35 to 85% RH	
	Insulation resistance	100 MΩ MIN (at 500VDC megger)	
	Dielectric strength	500 VAC 1 minute	
	Mass	40 g	

※: The pressure sensor is for analog output only. When switch output is necessary, a controller for the pressure sensor is required separately. Prepare our multi-channel, multi-sensor controller (MSU-□) separately.

Mass

● Single unit

Unit: g [oz.]

Basic model	Body mass		Additional mass			
			Exhaust method		Electronic vacuum switch	
	-T0	-TA (-TK, -T2)	-SH	-UR	-DA, -DR	-EA, -ER
FME□□□□	120 [4.23]	130 [4.59]	6 [0.21]	9 [0.32]	55 [1.94]	51 [1.80]
FMEA□□□□						
FME1A□□□□						
FMEA□□□□						
FME1AJ□□□□						
FMEC□□□□						
FMECJ□□□□						

The valve connector is not included in the mass.

The lead wire of electronic pressure switch is included in the mass.

Calculation example

For **FME05-TA-J4-SH-DA-PN DC24**

$$130+6+55 = 191 \text{ g [6.74 oz.]}$$

● Manifold

Unit: g [oz.]

Basic model	End block mass	-DN	Exhaust method			Serial transmission
			-F100N -F101N	-F200N -F201N -F260N	-D250N -D251N	
FMEM2A	78 [2.75]	85 [3.00]	164 [5.78]	166 [5.86]	170 [6.00]	138 [4.87]
FMEM3A	83 [2.93]	85 [3.00]				
FMEM4A	88 [3.10]	90 [3.17]				
FMEM5A	93 [3.28]	90 [3.17]				
FMEM6A	98 [3.46]	95 [3.35]				
FMEM7A	103 [3.63]	95 [3.35]				
FMEM8A	108 [3.81]	100 [3.53]				

Calculation example

FMEM4AN-DN stn.1 **FME1AJ05-TA-J4-SH-DA-PN DC24**
 stn.2 - 4 For **FMEA05-TA-J4-SH-DA-PN DC24**

$$191 + (191 \times 3) + 88 + 90 = 942 \text{ g [33.23 oz.]}$$

Symbol

FME□□□□-T0

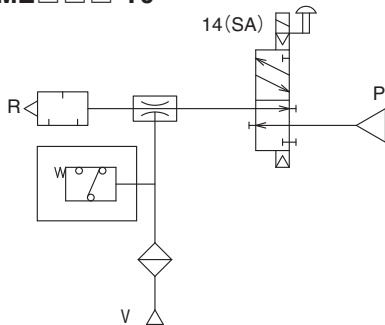

FME□□□□-TA(-TK)

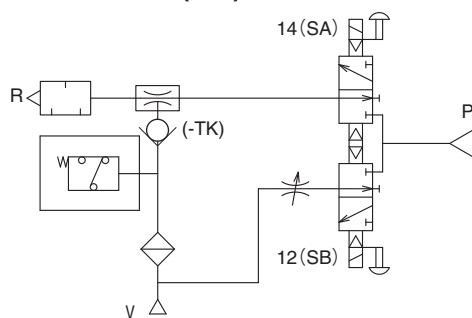

FME□□□□-T2

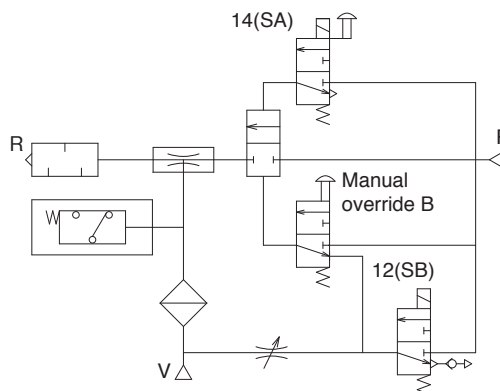

Note: The manual override B is to stop the generation of vacuum.
 (Not a supply button to break vacuum)

Single ejector order code

FME

Micro
ejector
FME
series

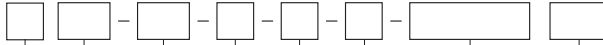

Voltage
DC12 : 12VDC
DC24 : 24VDC

Lead wire specifications

PN — S type plug connector, without connector, without lead wire

- PS** — S type plug connector, 300 mm [11.8 in.] lead wire
- CPS** — Pre-wired S type plug connector, 300 mm [11.8 in.] lead wire
- PS3** — S type plug connector, 3000 mm [118 in.] lead wire
- CPS3** — Pre-wired S type plug connector, 3000 mm [118 in.] lead wire
- PSK** — S-type plug connector + connector for vacuum switch
Lead wire connection type 1500 mm [59 in.]
(Can only be selected when TK and DR are selected)
- PSK3** — S-type plug connector + connector for vacuum switch
Lead wire connection type 3000 mm [118 in.]
(Can only be selected when TK and DR are selected)

Positive common
Negative common

- MS** — S type plug connector, 300 mm [11.8 in.] lead wire
- CMS** — Pre-wired S type plug connector, 300 mm [11.8 in.] lead wire
- MS3** — S type plug connector, 3000 mm [118 in.] lead wire
- CMS3** — Pre-wired S type plug connector, 3000 mm [118 in.] lead wire

Note: **CPS, CPS3, CMS, CMS3** cannot be selected when ordering a single ejector.

Exhaust method

- Blank** — Muffler exhaust
- SH** — Silent type muffler exhaust
- UR** — Port exhaust

Vacuum port fitting

- J4** — With ϕ 4 quick fittings
- J6** — With ϕ 6 quick fittings
- J1/8** — With 1/8 in. quick fittings
- J1/4** — With 1/4 in. quick fittings

Solenoid valve specifications

- T0** — Supply air control valve (NC)
- TA** — Supply air control valve (NC) & vacuum breaking air control valve (NC)
- TK** — Supply air control valve (NC) & vacuum breaking air control valve (NC) With vacuum holding function
- T2** — Supply air control valve (NC) & vacuum breaking air control valve (NC) With self holding function

Nozzle diameter mm [in.]

- 05** — ϕ 0.5 [0.020] standard
- 07** — ϕ 0.7 [0.028] standard
- 10** — ϕ 1.0 [0.039] standard
- 05L** — ϕ 0.5 [0.020] low pressure type
- 07L** — ϕ 0.7 [0.028] low pressure type
- 10L** — ϕ 1.0 [0.039] low pressure type

Piping specifications

- Blank** — Direct piping with a supply port ϕ 8 quick fitting for a single ejector use^{Note 2}
- J1/4** — Direct piping with a supply port 1/4 in. quick fitting for a single ejector use

Note1: ϕ 4 (Equivalent to 5/32 in.)
Note2: ϕ 8 (Equivalent to 5/16 in.)

Electronic vacuum switch

- Blank** — No vacuum switch
- DA** — With digital display vacuum switch
(One switch output variable hysteresis + analog output)
- DR** — With digital display vacuum switch, 1500 mm [59 in.] lead wire
(Compound pressure, two switch outputs variable hysteresis)
- DR3** — With digital display vacuum switch, 3000 mm [118 in.] lead wire
(Compound pressure, two switch outputs variable hysteresis)
- EA** — With sensor head for MSU
(0 to -101.3 kPa [0 to -29.92 in.Hg] negative pressure, analog output only)
- ER** — With sensor head for MSU
(-100 to 220 kPa [-29.5 in.Hg to 32 psi.] compound pressure, analog output only)

Note: Additional multi-channel, multi-sensor controller MSU is required to control **-EA** and **-ER**.
Vacuum switch can not be later mounted to the ejector body with no vacuum switch.

Attention

- ① Exterior color of pressure sensor heads will be changed from white to black. There is no change in performance.
- ② The body color, and the design of the Multi-Channel, Multi-Sensor Controller will be modified.

Manifold order code

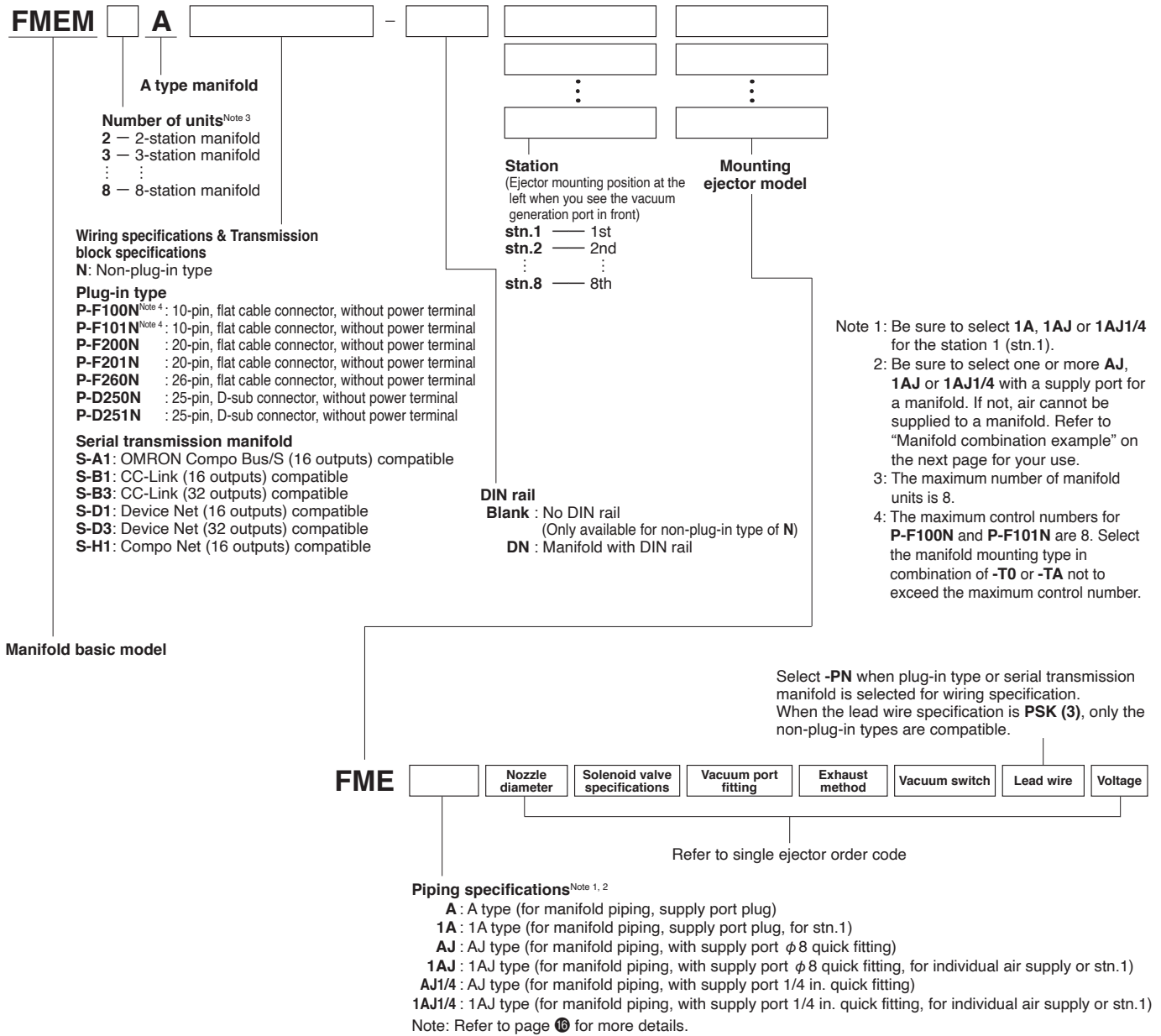

Manifold order code

■ Maximum number of valve units by wiring specifications (for plug-in type)

Wiring specifications		Maximum number of outputs	Maximum number of units
			Wiring connection specifications
			Packed wiring
P-F100N	Flat cable (10P)	8	The maximum number of units is 8. However, it varies according to the number of mounted single and double solenoids. Specify the number of units so that the number of controlling solenoids is equal to the maximum control number or smaller.
P-F101N	Flat cable (10P)	8	
P-F200N	Flat cable (20P)	16	
P-F201N	Flat cable (20P)	16	
P-F260N	Flat cable (26P)	20	
P-D250N	D-sub connector (25P)	16	
P-D251N	D-sub connector (25P)	20	

Example of manifold combination

1. When the supply port is placed on Station 1 (Stn.1):

FMEM4AN-DN

stn.1 **FME1AJ05-TA-J4-SH-DA-PS DC24**

stn.2 - 4 **FMEA05-TA-J4-SH-DA-PS DC24**

2. When different air pressure is supplied to each station (individual supply):

FMEM4AN-DN

stn.1 - 4 **FME1AJ05-TA-J4-SH-DA-PS DC24**

3. When supply ports are provided in 3 positions since vacuum is frequently generated simultaneously within the same manifold:
In the case of the installation, provide air supply ports to the Stations 1, 3, and 5.

FMEM5AN-DN

stn.1 **FME1AJ05-TA-J4-SH-DA-PS DC24**

stn.2 **FMEA05-TA-J4-SH-DA-PS DC24**

stn.3 **FMEAJ05-TA-J4-SH-DA-PS DC24**

stn.4 **FMEA05-TA-J4-SH-DA-PS DC24**

stn.5 **FMEAJ05-TA-J4-SH-DA-PS DC24**

Manifold order code and detailed description of piping specification

Piping specification	Type	Description
A	Type A	Supply port plug attached (piping not allowed). For stn.2 to stn.8.
1A	Type 1A	Supply port plug attached (piping not allowed), one-side isolator on the left. Select 1AJ or 1AJ1/4 if supply port is required for stn.1.
AJ	Type AJ	φ 8 quick fitting attached on the supply port. For stn.2 to stn.8. For use to locate multiple supply ports on manifold to ensure flow rate.
1AJ	Type 1AJ	φ 8 quick fitting attached on the supply port. One-side isolator on the left. For use with stn.1 and for individual supply.
AJ1/4	Type AJ	1/4 in. quick fitting attached on the supply port. For stn.2 to stn.8. For use to locate multiple supply ports on manifold to ensure flow rate.
1AJ1/4	Type 1AJ	1/4 in. quick fitting attached on the supply port. One-side isolator on the left. For use with stn.1 and for individual supply.

Electronic vacuum switch order code mm [in.]

MV -

Switch specifications

DA : One output of variable hysteresis type (with analog output)
DR : Two output of variable hysteresis type

MV-DA

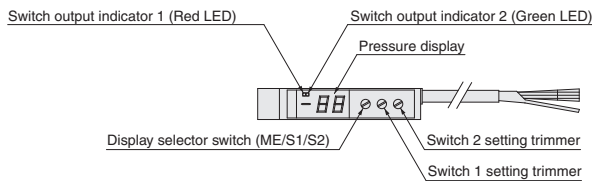
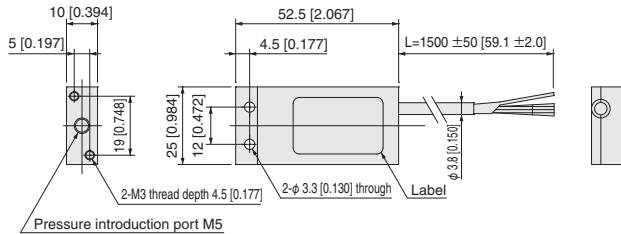

MV-DR

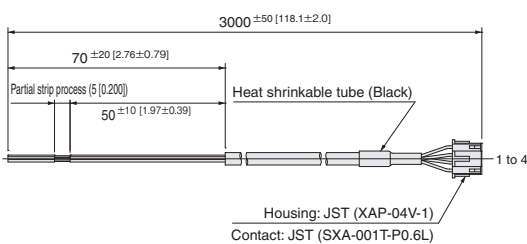
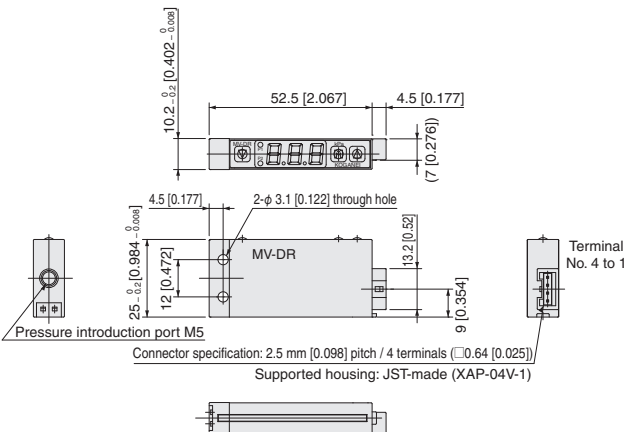

Pin No.	Lead wire	Terminal connection
1	Blue	COMMON
2	Brown	Power supply
3	White	SW output 2
4	Black	SW output 1

Note: The vacuum switch cannot be later installed to ejector body without vacuum switch.

Additional stacking unit order code (for addition of 1 unit used with manifold)

FME Nozzle diameter Solenoid valve specifications Voltage

Refer to single ejector order code

- C** : C type (supply port plug and 2 stacking rods included)
- 1C** : 1C type (supply port plug, for stn.1, 2 stacking rods included)
- CJ** : CJ type (supply port φ8 quick fitting, 2 stacking rods included)
- 1CJ** : 1CJ type (supply port φ8 quick fitting, independent supply or for stn.1, 2 stacking rods included)
- CJ1/4** : CJ type (supply port 1/4 in. quick fitting, 2 stacking rods included)
- 1CJ1/4** : 1CJ type (supply port 1/4 in. quick fitting, independent supply or for stn.1, 2 stacking rods included)

Note1: For the stacking unit, a stacking rod will be included for each ejector for manifold (FMEA(J) or FME1A(J)).
 For the order codes for ejector single units, refer to page 12.

Note2: For stn.1 of the manifold always select 1C or 1CJ, and refer to "Example of Manifold Combination" on page 13 for selection.

Replacement filter order code (element only)

FME-F (5 pcs. per bag)

Mounting bracket order code (for single ejector)

PSU-BR

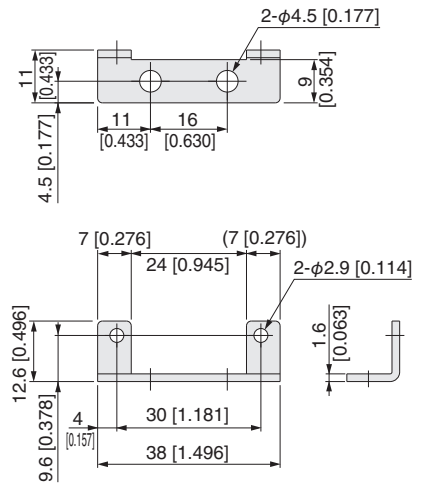
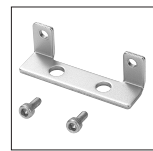

Hexagon socket head screw
 M2.6×0.45 length 5 [0.197] (2 pcs.) included

Connector-related order code

JAZ -

Valve specifications Connector specifications

- For **TA** **CP** : With connector and 300 mm [11.8 in.] lead wires (black, red and white, total 3 wires)
- CP3** : With connector and 3000 mm [118 in.] lead wires (black, red and white, total 3 wires)
- CPN** : Connector without lead wire (1 short bar, 3 contacts included)

JAZ0 -

Valve specifications Connector specifications

- For **T0** **CP** : With connector and 300 mm [11.8 in.] lead wires (black and red, total 2 wires)
- CP3** : With connector and 3000 mm [118 in.] lead wires (black and red, total 2 wires)
- CPN** : Connector without lead wire (1 short bar, 2 contacts included)

FZ -

Valve specifications Connector specifications

- For **TA** **CC1.5** : Cabtyre cable length 1500 mm [59 in.]
- CC3** : Cabtyre cable length 3000 mm [118 in.]

Cabtyre cable

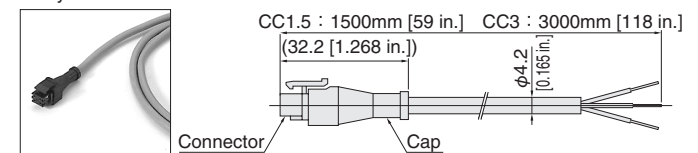

Operating Principles and Parts Names

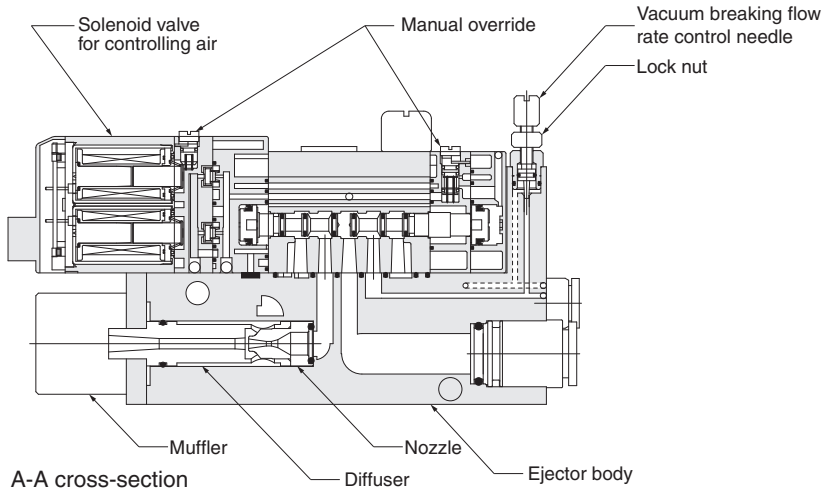

Major Parts

Ejector body	Plastic
Filter	Plastic
Nozzle diffuser	Plastic
Muffler	Plastic
O-ring	Synthetic rubber

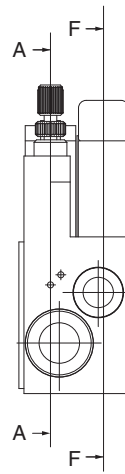
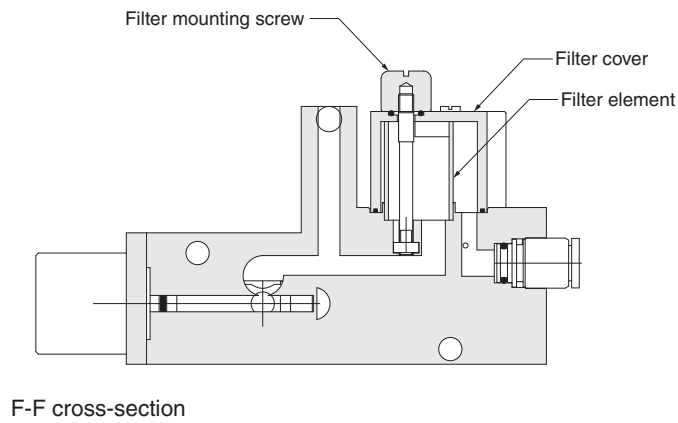

● When the solenoid valve (vacuum generation) 14 (SA) for controlling supply air is ON

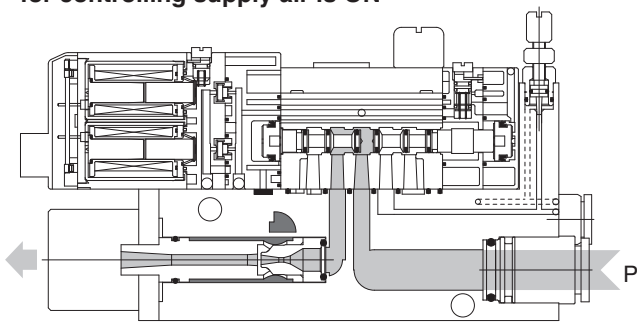

A-A cross-section

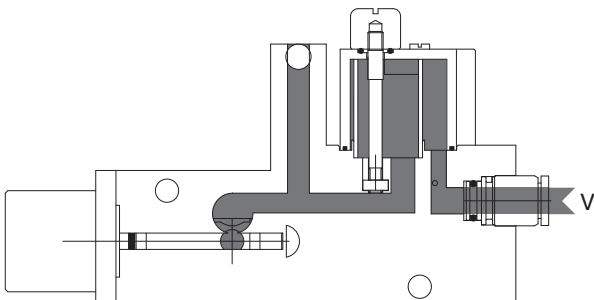

F-F cross-section

● When the solenoid valve 12 (SB) for controlling vacuum breaking air is ON

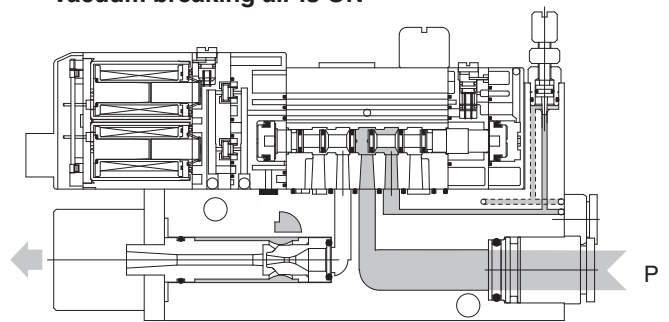

A-A cross-section

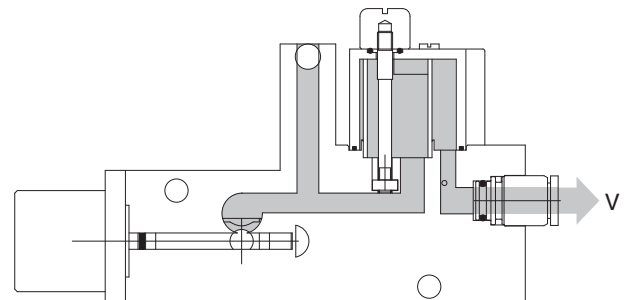

F-F cross-section

Plug-in Type: Pin (Terminal) Locations by Wiring Specifications (TOP VIEW)

Flat cable connector (10-pin)

● **P-F100N** (maximum number of control pins : 8)

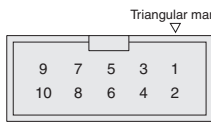

1 to 8 : Control pins
9 and 10 : Common pins
(short-circuited in the wiring block)

● **P-F101N** (maximum number of control pins : 8)

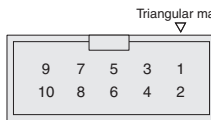

1 to 8 : Control pins
9 : NC (reserved pin)
10 : (+) pin

Flat cable connector (20-pin)

● **P-F200N** (maximum number of control pins : 16)



1 to 16 : Control pins
17 and 18 : NC (reserved pins)
19 and 20 : (+) pins
(short-circuited in the wiring block)

● **P-F201N** (maximum number of control pins : 16)

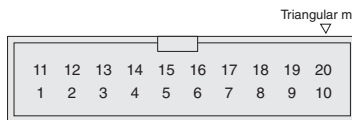

1 to 8 : Control pins
11 to 18 : Control pins
9 and 19 : NC (reserved pins)
10 and 20 : (+) pins
(short-circuited in the wiring block)

Note The above pin Nos are assigned for convenience.
Use the ▽ mark as a reference point.

D-sub connector (25-pin)

● **P-D250N** (maximum number of control pins : 16)



1 to 16 : Control pins
20, 21 and 22 : NC (reserved pins)
23, 24 and 25 : (+) pins (short-circuited in the wiring block)

Note The above pin Nos. are assigned based on the order of connections to the solenoid valve for convenience.
Be aware that they are different from locations and pin Nos. (engraved) specified in the data circuit-terminating equipment (DCE) (JIS-X5101).

● **P-D251N**

JIS specification pin locations (maximum number of control pins : 20)



1 to 10, and 14 to 23 : Control pins
12 and 13 : NC (reserved pins)
24 and 25 : (+) pins
(short-circuited in the wiring block)

Flat cable connector (26-pin)

● **P-F260N** (maximum number of control pins : 20)

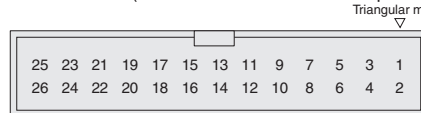

1 to 20 : Control pins
23 and 24 : NC (reserved pins)
25 and 26 : (+) pins
(short-circuited in the wiring block)

Detailed wiring system diagram

Flat cable wiring and D-sub connector (12, 24 V DC)

● Positive common

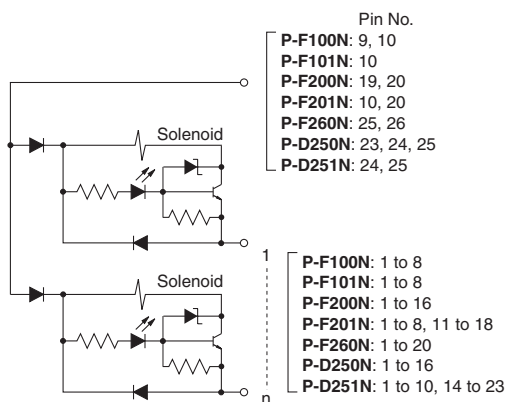

Pin No. (terminal No.) and compatible solenoid (for plug-in type)

The example below shows the relationship between plug-in type manifold pin No. (terminal No.) and compatible solenoid.

Flat cable connector (10-pin)

● For wiring specifications **P-F100N** (maximum number of control pins : 8)

Ex: **FMEM5AP-F100N** stn.1 FME1AJ05-T0-J4-SH-DA-PN DC24
 stn.2 FMEA05-T0-J4-SH-DA-PN DC24
 stn.3 - 5 FMEA05-TA-J4-SH-DA-PN DC24

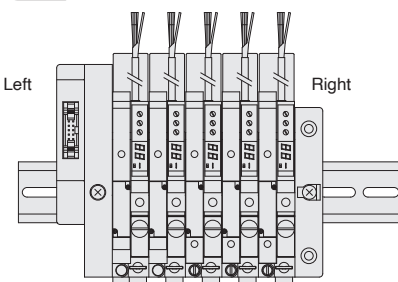

Left Right

Number of units: 5
 Wiring specifications: **P-F100N**

(TOP VIEW) Triangular mark



Pin No.	9	7	5	3	1
Valve No.	+	5A	4A	3A	1A
Pin No.	10	8	6	4	2
Valve No.	+	5B	4B	3B	2A

Flat cable connector (10-pin)

● For wiring specifications **P-F101N** (maximum number of control pins : 8)

Ex: **FMEM5AP-F101N** stn.1 FME1AJ05-T0-J4-SH-DA-PN DC24
 stn.2 FMEA05-T0-J4-SH-DA-PN DC24
 stn.3 - 5 FMEA05-TA-J4-SH-DA-PN DC24

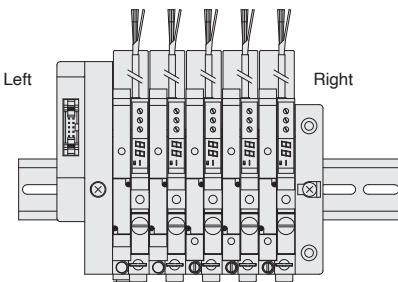

Left Right

Number of units: 5
 Wiring specifications: **P-F101N**

(TOP VIEW) Triangular mark

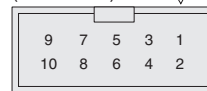

Pin No.	9	7	5	3	1
Valve No.	NC	5A	4A	3A	1A
Pin No.	10	8	6	4	2
Valve No.	+	5B	4B	3B	2A

Flat cable connector (20-pin)

● For wiring specifications **P-F200N** (maximum number of control pins : 16)

Ex: **FMEM8AP-F200N** stn.1 FME1AJ05-T0-J4-SH-DA-PN DC24
 stn.2 FMEA05-T0-J4-SH-DA-PN DC24
 stn.3 - 8 FMEA05-TA-J4-SH-DA-PN DC24

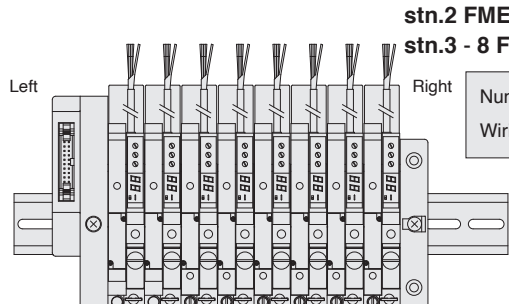

Left Right

Number of units: 8
 Wiring specifications: **P-F200N**

(TOP VIEW)

Triangular mark



Pin No.	19	17	15	13	11	9	7	5	3	1
Valve No.	+	NC		8A	7A	6A	5A	4A	3A	1A
Pin No.	20	18	16	14	12	10	8	6	4	2
Valve No.	+	NC		8B	7B	6B	5B	4B	3B	2A

Flat cable connector (20-pin)

● For wiring specifications **P-F201N** (maximum number of control pins : 16)

Ex: **FMEM8AP-F201N** stn.1 FME1AJ05-T0-J4-SH-DA-PN DC24
 stn.2 FMEA05-T0-J4-SH-DA-PN DC24
 stn.3 - 8 FMEA05-TA-J4-SH-DA-PN DC24

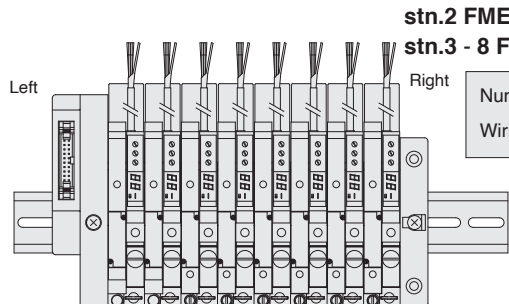

Left Right

Number of units: 8
 Wiring specifications: **P-F201N**

(TOP VIEW)

Triangular mark

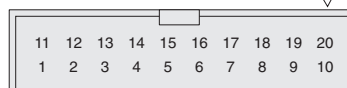

Pin No.	11	12	13	14	15	16	17	18	19	20
Valve No.	6A	6B	7A	7B	8A	8B			NC	+
Pin No.	1	2	3	4	5	6	7	8	9	10
Valve No.	1A	2A	3A	3B	4A	4B	5A	5B	NC	+

Note 1: The valve number in No.1A, 1B, 2A, and 2B, ... Arabic numerals represent the stn. numbers, and alphabets A and B represent the solenoid, A or B side.

2: Stn. No. is 1, 2... from the left as you see the valve in front and solenoid above.

3: The connector pin Nos. are assigned for convenience. Use the ▽ mark as a reference point.

Pin No. (terminal No.) and compatible solenoid (for plug-in type)

The example below shows the relationship between plug-in type manifold pin No. (terminal No.) and compatible solenoid.

Flat cable connector (26-pin)

● For wiring specifications **P-F260N** (maximum number of control pins : 20)

Ex: FMEM8AP-F260N stn.1 FME1AJ05-TA-J4-SH-DA-PN DC24
 stn.2 - 8 FMEA05-TA-J4-SH-DA-PN DC24

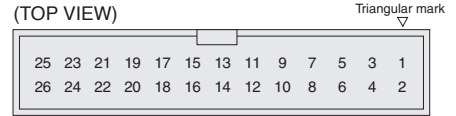
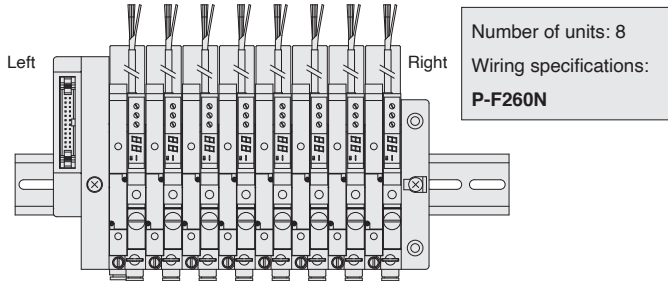

Pin No.	25	23	21	19	17	15	13	11	9	7	5	3	1
Valve No.	+	NC				8A	7A	6A	5A	4A	3A	2A	1A
Pin No.	26	24	22	20	18	16	14	12	10	8	6	4	2
Valve No.	+	NC				8B	7B	6B	5B	4B	3B	2B	1B

D-sub connector (25-pin)

● For wiring specifications **P-D250N** (maximum number of control pins : 16)

Ex: FMEM8AP-D250N stn.1 FME1AJ05-T0-J4-SH-DA-PN DC24
 stn.2 - 8 FMEA05-TA-J4-SH-DA-PN DC24

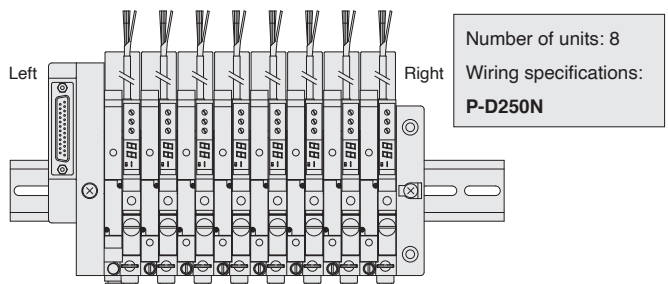

Note The connector pin Nos. are assigned based on the order of wiring connections to the solenoid valve for convenience. Be aware that they are different from locations and pin Nos. (engraved) specified in the data circuit-terminating equipment (DCE) (JIS-X5101).

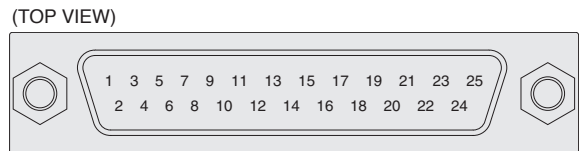

Pin No.	1	3	5	7	9	11	13	15	17	19	21	23	25
Valve No.	1A	2B	3B	4B	5B	6B	7B	8B			NC	+	+
Pin No.	2	4	6	8	10	12	14	16	18	20	22	24	
Valve No.	2A	3A	4A	5A	6A	7A	8A			NC	NC	+	

D-sub connector (25-pin)

● For wiring specifications **P-D251N** JIS specifications pin locations (maximum number of control pins : 20)

Ex: FMEM8AP-D251N stn.1 FME1AJ05-T0-J4-SH-DA-PN DC24
 stn.2 - 8 FMEA05-TA-J4-SH-DA-PN DC24

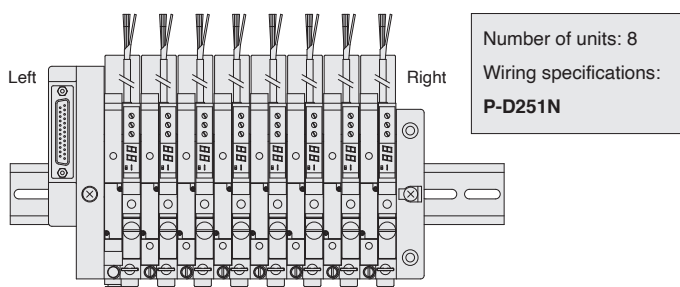

Pin No.	1	2	3	4	5	6	7	8	9	10	11	12	13
Valve No.	1A	2A	2B	3A	3B	4A	4B	5A	5B	6A		NC	NC
Pin No.	14	15	16	17	18	19	20	21	22	23	24	25	
Valve No.	6B	7A	7B	8A	8B						+	+	

Note 1: The valve number in No.1A, 1B, 2A, and 2B, ... Arabic numerals represent the stn. numbers, and alphabets A and B represent the solenoid, A or B side.
 2: Stn. No. is 1, 2... from the left as you see the valve in front and solenoid above.
 3: The connector pin Nos. are assigned for convenience. Use the ▽ mark as a reference point.

Serial Transmission Compatible Manifold Specifications

General specifications

Power supply voltage	24VDC ±10%
Operating temperature range	5 to 50°C [41 to 122°F]
Vibration resistance	49.0 m/s ² [5G]
Shock resistance	98.1 m/s ² [10G]

Serial Transmission Block: Terminal Block Part Names (LED)

●OMRON Corporation CompoBus/S compatible

Transmission block specifications: **S-A1** (16 outputs)

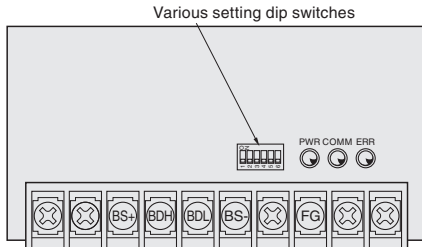

LED Indicator

Indicator	Status	Color	Description
PWR	Lights up	Green	• Power supplied
	Shut off		• Power OFF
COMM	Lights up	Yellow	• Normal communication
	Shut off		• Communication failure or waiting
ERR	Lights up	Red	• Communication failure
	Shut off		• Normal communication or waiting

Remarks

※For more information on CompoBus/S, refer to documents such as catalog and instruction manuals provided by OMRON Corporation.

- Number of outputs per block
16 valve solenoids (transmission block specifications: **S-A1**)

●CC-Link compatible

Transmission block specifications: **S-B1** (16 outputs)

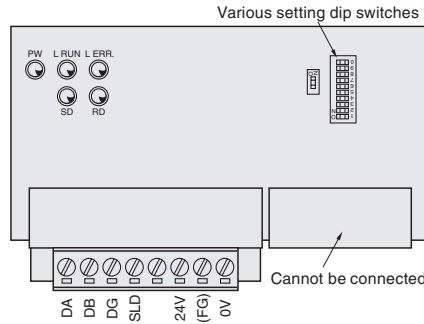

Names of LEDs

Indicator	Description
PW	• Turned on by power ON
L RUN	• Turned on by receiving normal data from master station
SD	• Turned on by data transmission
RD	• Turned on by receiving data
L ERR.	• Turned on by transmission error and off by timeout Turned on by erroneous station setting or transmission speed setting

Remarks

- ※ Compliant with CC-Link.
- Number of outputs per block
16 valve solenoids (transmission block specifications: **S-B1**)
- ※ As this block occupies 1 station, up to 64 units can be connected to 1 master station if remote I/O stations are configured all with this block.

●CC-Link compatible

Transmission block specifications: **S-B3** (32 outputs)

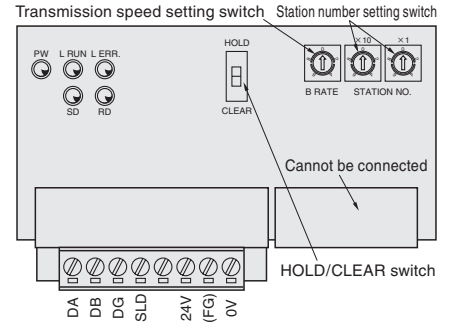

Names of LEDs

Indicator	Description
PW	• Turned on by power ON
L RUN	• Turned on by receiving normal data from master station
SD	• Turned on by data transmission
RD	• Turned on by receiving data
L ERR.	• Turned on by transmission error and off by timeout Turned on by erroneous station setting or transmission speed setting

Remarks

- ※ Compliant with CC-Link.
- Number of outputs per block
32 valve solenoids (transmission block specifications: **S-B3**)
- ※ As this block occupies 1 station, up to 64 units can be connected to 1 master station if remote I/O stations are configured all with this block.

Serial Transmission Block: Terminal Block Part Names (LED)

●DeviceNet compatible

Transmission block specifications: **S-D1** (16 outputs)
S-D3 (32 outputs)

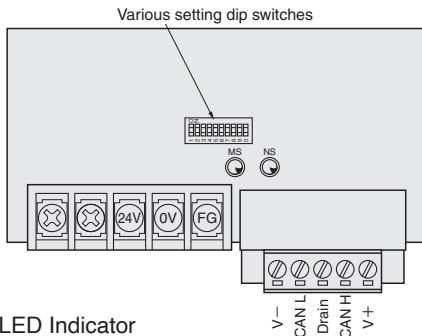

LED Indicator

Indicator	Status	Color	Description
MS	Lights up	Green	• Normal state
	Blink		• Not set
	Lights up	Red	• Critical breakdown
	Blink		• Minor breakdown
	Shut off	—	• No power supply
	NS	Lights up	Green
Blink		• Communication not connected	
Lights up		Red	• Critical communication failure
Blink			• Minor communication failure
Shut off		—	• No power supply

Remarks

- ※ Compliant with DeviceNet.
- Number of outputs per block
The number of valve solenoids is up to 16 for **S-D1** and up to 32 for **S-D3**

●CompoNet compatible

Transmission block specifications: **S-H1** (16 outputs)

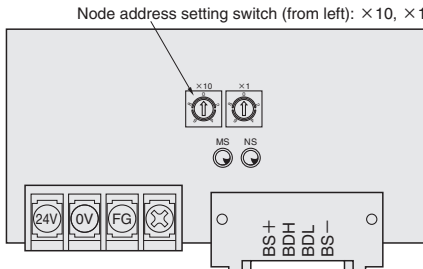

LED Indicator

Indicator	Status	Color	Description
MS	Lights up	Green	• Normal state
	Lights up	Red	• Critical failure
	Blink	Red	• Minor failure
	Shut off	—	• Power OFF/Preparing
NS	Lights up	Green	• Online/Subscribing
	Blink	Green	• Online/Not subscribing
	Lights up	Red	• Critical communication-related failure
	Blink	Red	• Minor communication-related failure
Shut off	—	• Power OFF/Preparing	

Remarks

- ※ Compliant with CompoNet.
- Number of outputs per block
16 valve solenoids (transmission block specifications: **S-H1**)
- ※ Communication connectors are available from OMRON Corporation. For connectors, contact OMRON Corporation.

Dimensions for Stand-alone Unit mm [in.]

● FME□□□-T0-J□-PN DC24

● FMEJ1/4□□□-T0-J□-PN DC24

(Unit outer dimensions are the same for 05, 05L, 07, 07L, 10, and 10L)

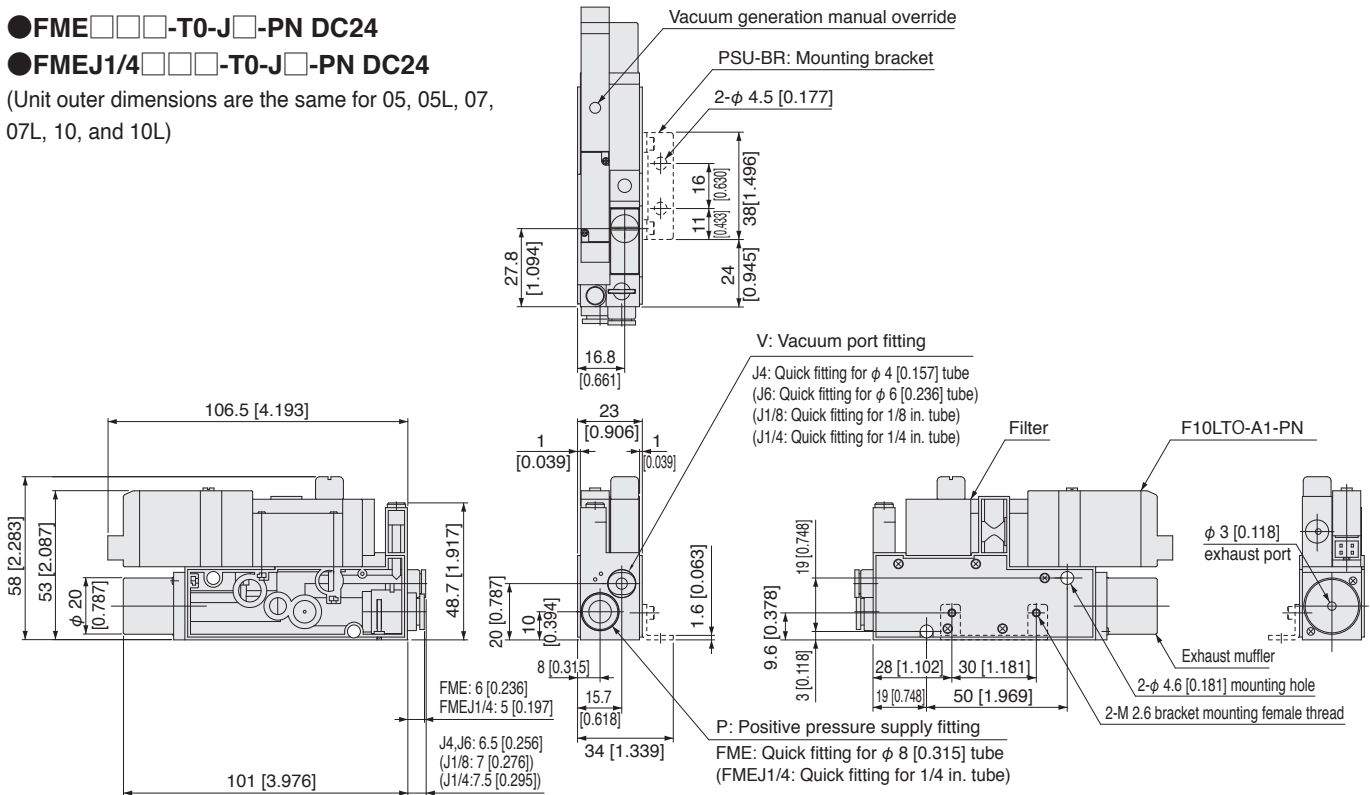

● FME□□□-TA-J□-PN DC24

● FMEJ1/4□□□-TA-J□-PN DC24

● FME□□□-TK-J□-PN DC24

● FME□□□-T2-J□-PN DC24

(Unit outer dimensions are the same for 05, 05L, 07, 07L, 10, and 10L)

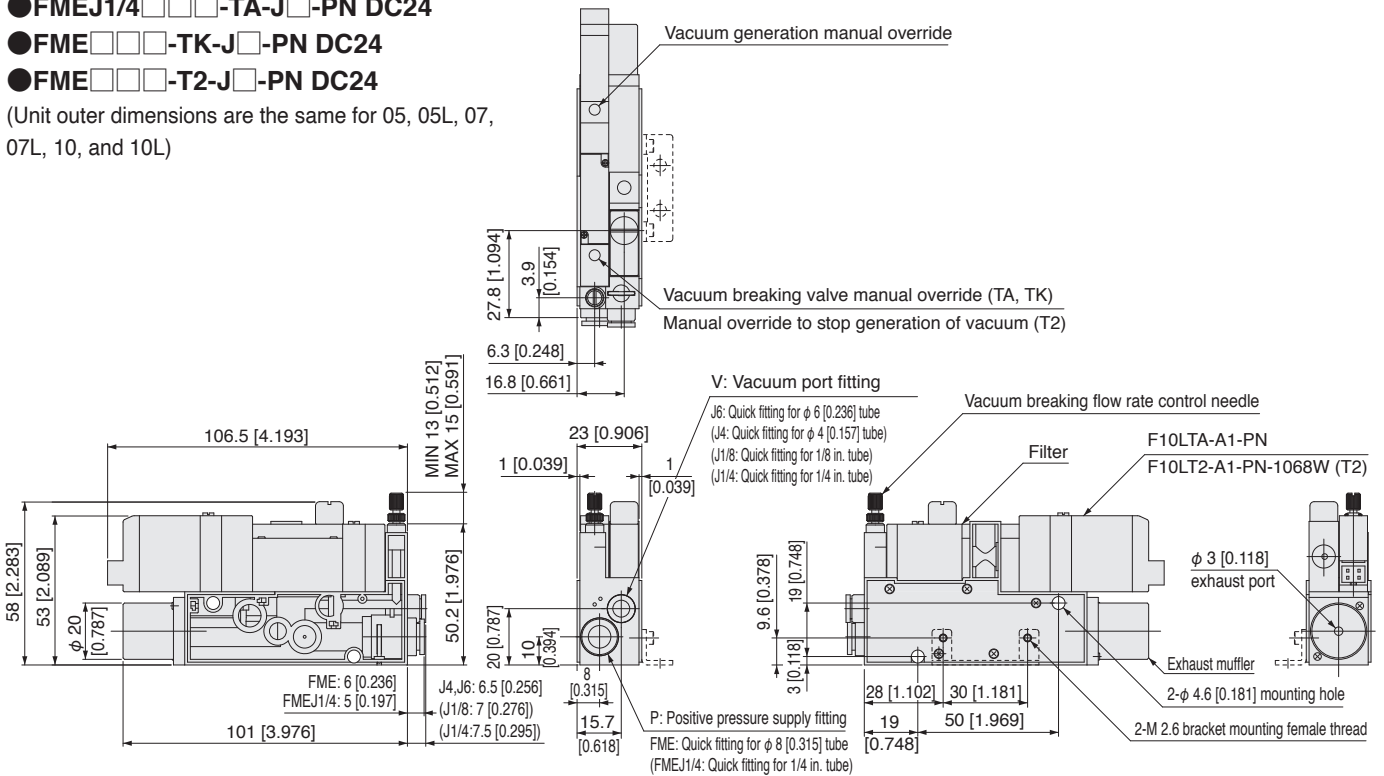

Option examples

FME□□□-TA-J6-SH-PN DC24

FME□□□-TK-J6-SH-PN DC24

FME□□□-T2-J6-SH-PN DC24

FME□□□-TA-J4-UR-PN DC24

FME□□□-TK-J4-UR-PN DC24

FME□□□-T2-J4-UR-PN DC24

FME□□□-TA-J6-DR-PN DC24

FME□□□-TK-J6-DR-PN DC24

FME□□□-T2-J6-DR-PN DC24

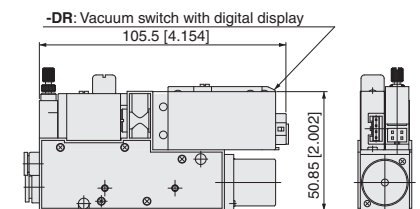
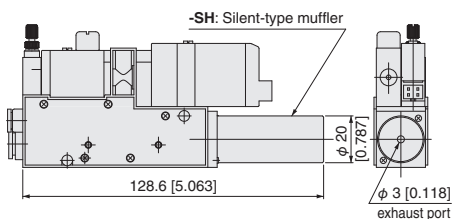

Dimensions for Manifold mm [in.]

FMEM□AN

Number of units

Configuration example

FMEM4AN

stn.1:FME1AJ □□□-T0-J4 -PN DC24

stn.2:FMEA □□□-TA-J6 -SH-DR-PN DC24

stn.3:FMEA □□□-TA-J1/8-SH-DA-PN DC24

stn.4:FMEA J1/4 □□□-TA-J1/4-UR-EA-PN DC24

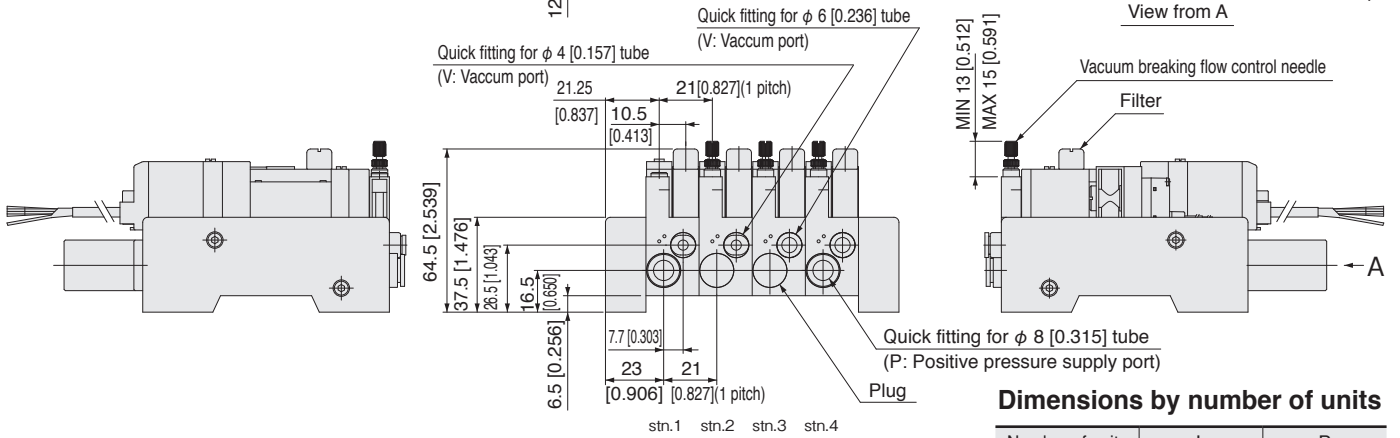
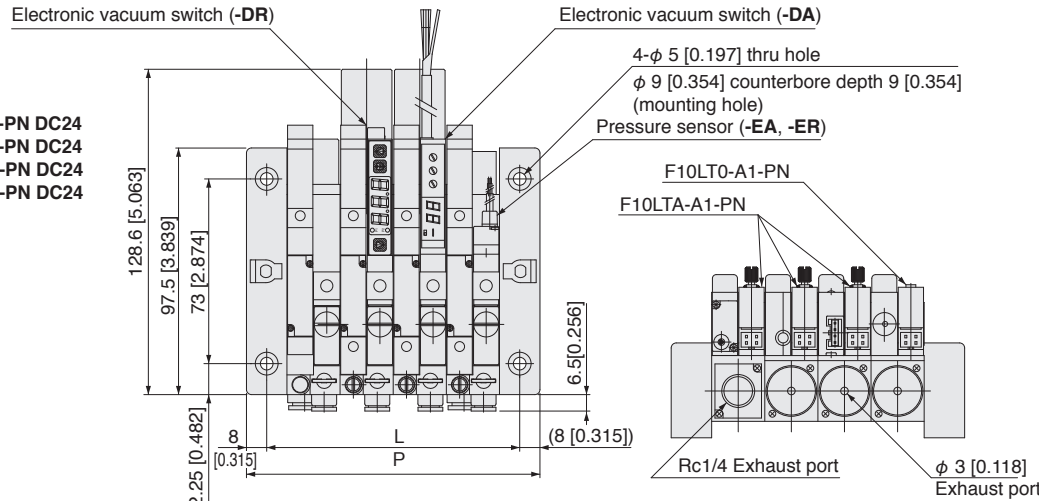

Dimensions by number of units

Number of units	L	P
2	58 [2.283]	74 [2.913]
3	79 [3.110]	95 [3.740]
4	100 [3.937]	116 [4.567]
5	121 [4.764]	137 [5.394]
6	142 [5.591]	158 [6.220]
7	163 [6.417]	179 [7.047]
8	184 [7.244]	200 [7.874]

FMEM□AN-DN

Number of units

Configuration example

FMEM4AN-DN

stn.1:FME1AJ □□□-T0-J4 -PN DC24

stn.2:FMEA □□□-TA-J6 -SH-DR-PN DC24

stn.3:FMEA □□□-TA-J1/8-SH-DA-PN DC24

stn.4:FMEA J1/4 □□□-TA-J1/4-UR-EA-PN DC24

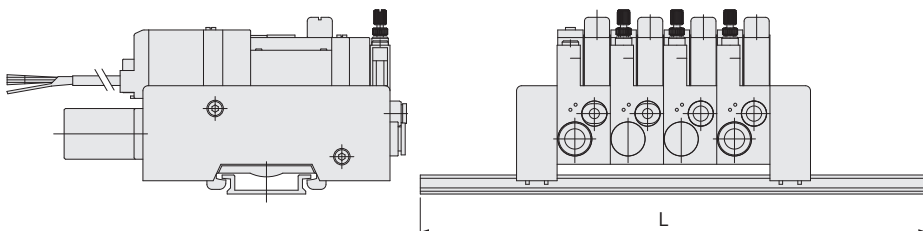
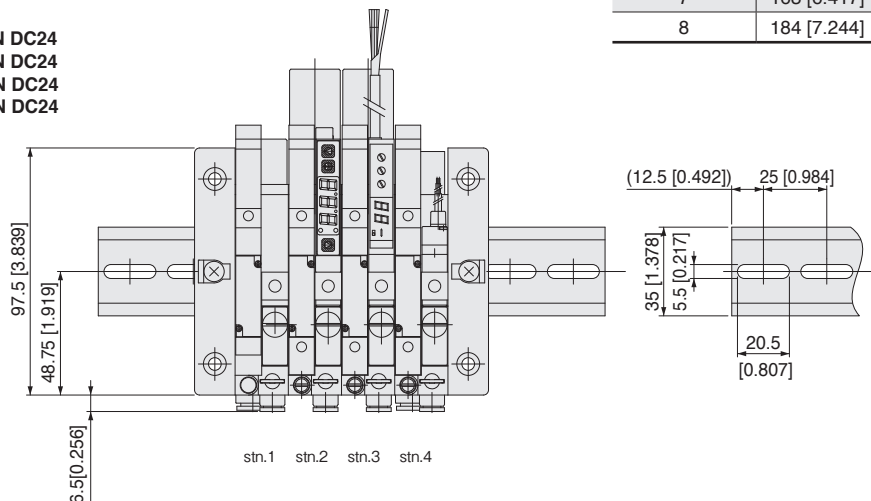

Dimensions for DIN rail

Manifold number of units	L dimensions
2	150 ± 2 [5.91 ± 0.08]
3	175 ± 2 [6.89 ± 0.08]
4	200 ± 2 [7.87 ± 0.08]
5	225 ± 2 [8.86 ± 0.08]
6	250 ± 2 [9.84 ± 0.08]
7, 8	275 ± 2 [10.83 ± 0.08]

Dimensions for Stand-alone Unit mm [in.]

● FMEM AP-F200N-DN (-F201N)

Number of units

Configuration example

FMEM4AP-F200N-DN

stn.1:FME1AJ -T0-J4 -PN DC24

stn.2:FMEA -TA-J6 -SH-DR-PN DC24

stn.3:FMEA -TA-J1/8-SH-DA-PN DC24

stn.4:FMEA J1/4 -TA-J1/4-UR-EA-PN DC24

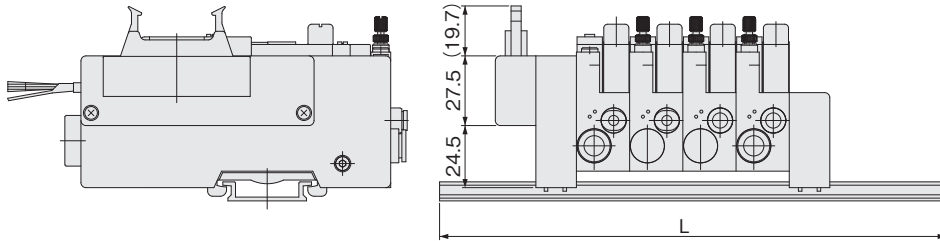
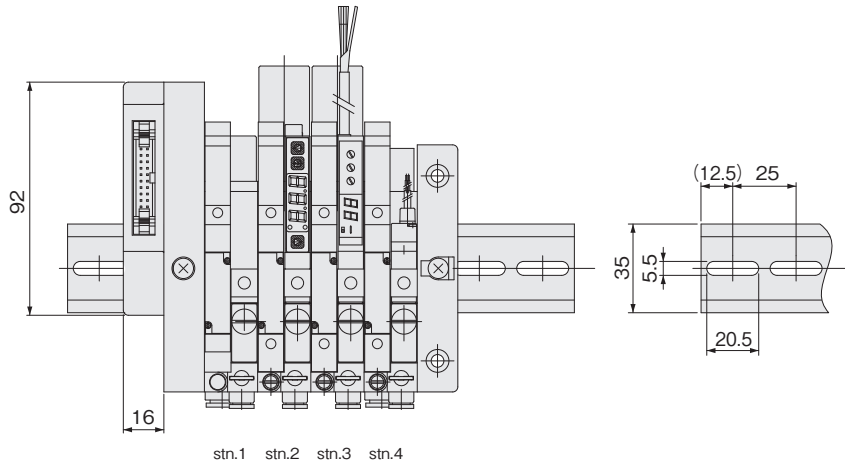

Dimensions for DIN rail

Manifold number of units	L dimensions
2	150 ± 2 [5.91 ± 0.08]
3	175 ± 2 [6.89 ± 0.08]
4	200 ± 2 [7.87 ± 0.08]
5	225 ± 2 [8.86 ± 0.08]
6	250 ± 2 [9.84 ± 0.08]
7, 8	275 ± 2 [10.83 ± 0.08]

● FMEM AS-A1-DN (-B1, -B3, -D1, -D3, -H1)

Number of units

Configuration example

FMEM4AS-A1-DN

stn.1:FME1AJ -T0-J4 -PN DC24

stn.2:FMEA -TA-J6 -SH-DR-PN DC24

stn.3:FMEA -TA-J1/8-SH-DA-PN DC24

stn.4:FMEA J1/4 -TA-J1/4-UR-EA-PN DC24

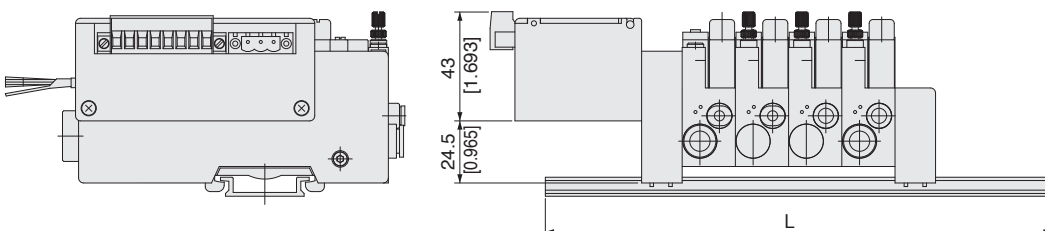
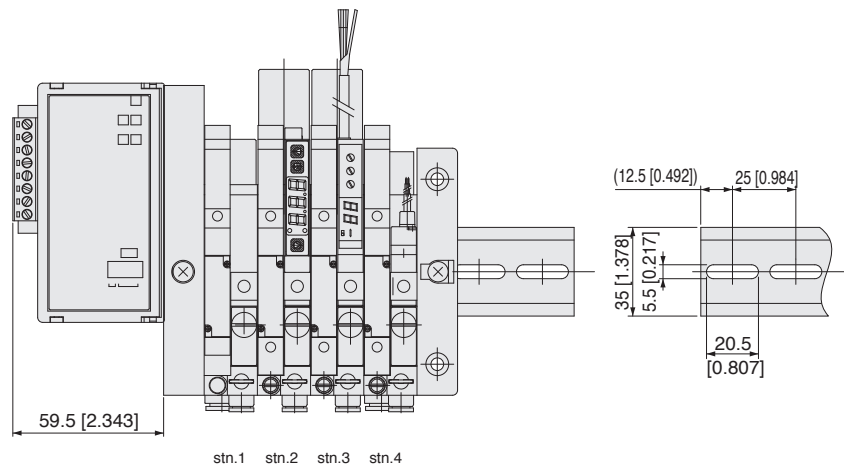

Dimensions for DIN rail

Manifold number of units	L dimensions
2	150 ± 2 [5.91 ± 0.08]
3	175 ± 2 [6.89 ± 0.08]
4	200 ± 2 [7.87 ± 0.08]
5	225 ± 2 [8.86 ± 0.08]
6	250 ± 2 [9.84 ± 0.08]
7, 8	275 ± 2 [10.83 ± 0.08]

Handling Instructions and Precautions



Electronic vacuum switch

Setting

●-DA (MV-DA)

One switch output (variable hysteresis) + Analog output type

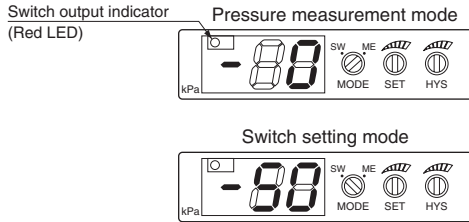

- (1) Set the display selector switch (MODE) on "SW".
- (2) Turn the pressure setting trimmer 1 (SET) to set switch operation pressure.
- (3) Turn the hysteresis setting trimmer (HYS) to set hysteresis.
- (4) Return the display selector switch (MODE) to "ME".

- Note**
1. Actually apply/change the pressure for high accuracy setting and make repeated adjustment so that the switch is operated at desired pressure.
 2. The switch setting range (variable range of setting trimmer) is not consistent with the pressure display range. Though the display range is "0 to 99," some %FS can be set below 0 and over 99.
 3. Do not use excessive force for handling of the display switch and pressure setting trimmer. Rotating torque for them shall be 0.025 N·m [0.22 in·lbf] or lower.

●-DR,-DR3 (MV-DR)

Two switch output (variable hysteresis) type

- (1) Names of operation panel parts

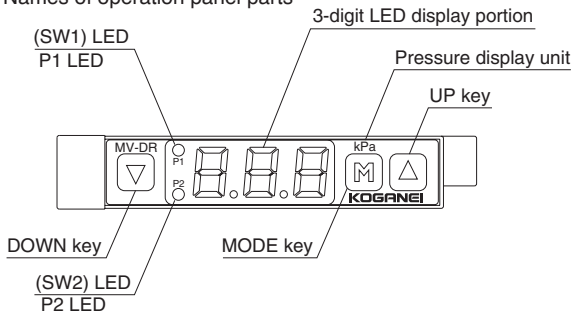

- (2) About error indication

• Take the following actions in the event of any error.

Error display	
Description	Overload current is flowing. (LED of overload-detected SW1 or SW2 is blinking.)
Remedy	Turn off the power and check the load status.
Error display	
Description	Pressure is applied when performing zero-point adjustment.
Remedy	Press key to release , set the applied pressure to a pressure port to atmospheric pressure, and then perform zero-point adjustment again.
Error display	
Description	The applied pressure exceeds the upper limit of the displayed pressure range.
Processing method	Check the applied pressure.

- (3) Functions

■ Startup display check

Turning on the power performs displaying of all indications once.

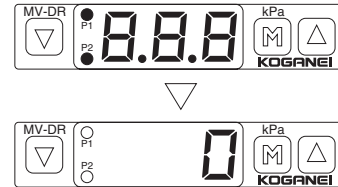

Start the pressure detection processing in operation mode.

■ Nondisplay mode (low heat generation)



Non-display mode operation is expected to reduce the amount of heat generation.

- Only when the 3-digit LED is set to hide in initial settings, it enters to the nondisplay mode and the 3-digit LED is turned off after about 10 seconds without key operations during operation.

- Note**
1. In the mode, the decimal point in the above figure blinks to show it is in operation.
 2. Even in the mode, SW output and SW output indicator operate normally.
 3. Even in the mode, SW overload is detected and an error is indicated.
 4. For setting of nondisplay mode, refer to the initial setting mode.

■ Display range

- Display range can be selected from the table below.

- Note**
1. "—" dash: Scale factor cannot be selected due to resolution and display digit limitation.
 2. For setting of display selection, refer to the initial setting mode.

Selected number	Pressure range
1	-100 to 300
2	—
3	-75 to 225
4	-1.00 to 3.00
5	-14.5 to 43.5
6	29.5 to 0.0 (Atmospheric pressure)

Handling Instructions and Precautions

Switch output

• Switch output can be selected from the table below.

- Note**
- In the separate mode, Setting 1 and Setting 2 are correlated with SW1 and SW2, respectively.
 - In the wind comparator mode, the unit operates with the lower limit value (Setting 1) and upper limit value (Setting 2) those are common to SW1 and SW2.
 - For setting of switch output, refer to the initial setting mode.

Selected number	Output	SW1				SW2			
	Mode	Separate		Wind comparator		Separate		Wind comparator	
	Operation	H	L	A	B	H	L	A	B
1		○				○			
2		○					○		
3			○					○	
4			○					○	
5				○					○
6				○					○
7					○				○
8					○				○
		Setting 1	(Lower limit): Setting 1 (Upper limit): Setting 2		Setting 2	(Lower limit): Setting 1 (Upper limit): Setting 2			

There are four types of operations as shown in the below diagram.

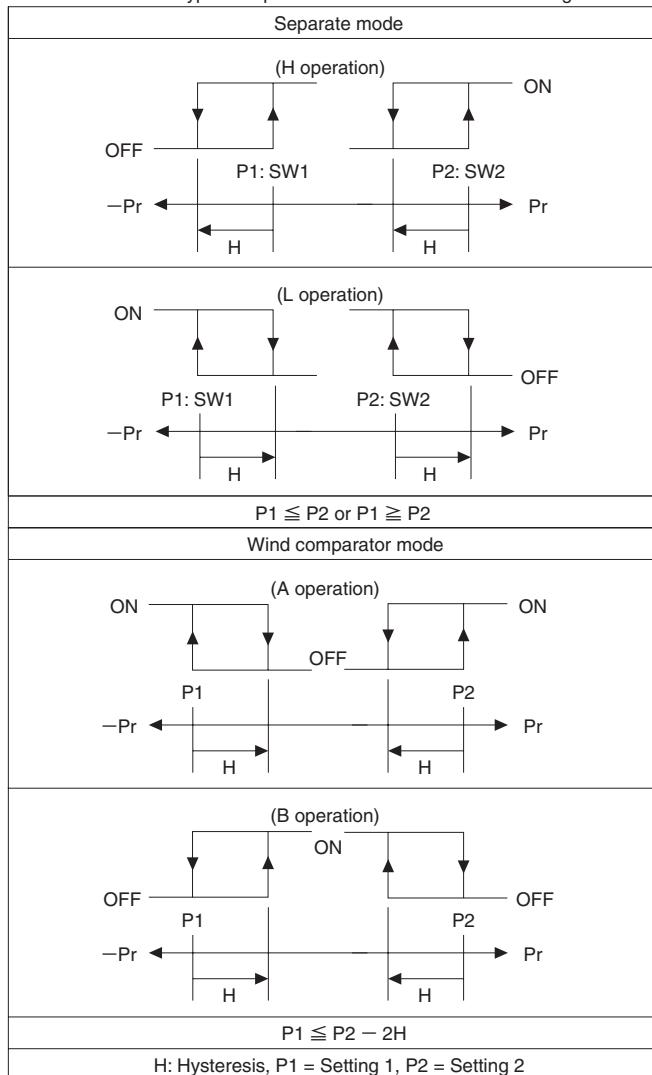

Digital filter

• 2 types of digital filter (25 ms, 250 ms) can be selected. Use them when indication is illegible due to significant variation of pressure.

- Note**
- The selected digital filter is applied to the pressure display and switch output.
 - For setting of digital filter, refer to the pressure setting mode.

(4) Operation procedure

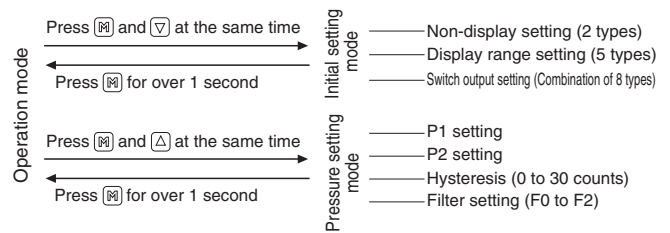

(5) Initial setting mode

• Set nondisplay mode, display range, and switch output.

■ Set the mode to initial setting mode.



Press [V] and [M] keys at the same time for over 1 second in the operation mode.

Once the operation enters the initial setting mode, third digit begins to blink and current setting is displayed.

Note Factory default setting is 2.11.

■ Set the initial conditions.



Pressing [M] key once (do not press the key for over 1 second) will move the setting to next digit, and the digit will blink.

Using [V] or [A] key, select to display the setting condition.

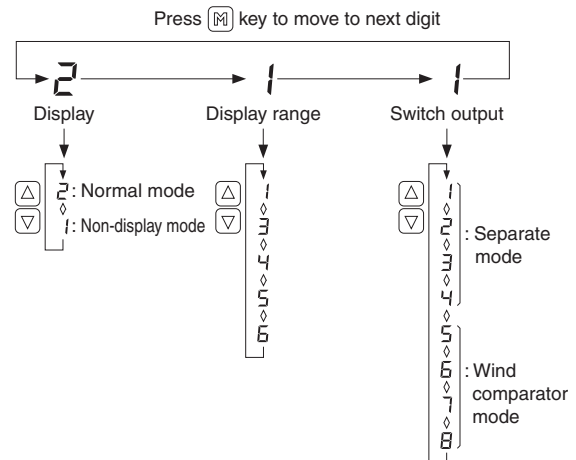

Handling Instructions and Precautions

(6) Pressure setting mode

- Set setting 1, setting 2, hysteresis, and digital filter.

■ Set the mode to pressure setting mode.



Press ∇ and \triangle keys at the same time for over 1 second in the operation mode. Once the operation enters the initial setting mode, P1 LED begins to blink and current setting is displayed in the LED display portion. Pressing ∇ key once (do not press the key for over 1 second) will move the setting to next item. However, if the key is pressed for over 1 second, the setting is fixed and the mode returns to the operation mode.

■ Set the pressure value.

Setting of setting 1 (P1)



Once the operation enters P1 setting, the P1 LED begins to blink and current setting value is displayed.

- Note**
1. Factory default settings of P1 and P2 are 050 .
 2. Settable range shall be within 110% of the rated pressure.
 3. If the SW operation is in wind comparator mode, perform the setting under the condition of $P1 \leq P2 - 2H$.

Setting of setting 2 (P2)



Once the operation enters P2 setting, the P2 LED begins to blink and current setting value is displayed.

- Note**
1. Settable range shall be within 110% of the rated pressure.
 2. If the SW operation is in wind comparator mode, perform the setting under the condition of $P1 \leq P2 - 2H$.

Setting of hysteresis (H)



Once the operation enters Hysteresis setting, the P1 and P2 LEDs begin to blink and current setting value is displayed.

- Note**
1. Factory default setting of hysteresis (H) is 00 .
 2. Settable range is within 30 counts.
 3. If the SW operation is in wind comparator mode, perform the setting under the condition of $P1 \leq P2 - 2H$.

Setting of digital filter



Once the operation enters filter setting, current setting value is displayed without blinking of the LED.

- Note**
1. Factory default setting of digital filter is $F0$.
 2. Selectable settings are three types of $F0$: No filter, $F1$: 25 ms filter, and $F2$: 250 ms filter.

(7) Zero-point adjustment

■ Zero reset

- The displayed pressure when opening the pressure port is adjusted to 0. First, open the pressure port to atmosphere, and then set the applied pressure to 0. Press the ∇ and \triangle keys at the same time in the operation mode, and when $0A$ begins to blink in the LED display portion, release the keys. This will detect the port pressure about 1 second later, and then perform zero-point adjustment.



When blinking of $0A$ stops, the adjustment is completed.

The adjusted value remains valid until the next zero-point adjustment is performed.

(8) Setting protection

■ Panel lock

- Lock the key operation and protect the setting value. When continuing to press the \triangle key for over 3 seconds in the operation mode, PL begins to blink in the LED display portion and the operation gets in lock mode. Display in the lock mode and output operation correctly functions. When continuing to press the ∇ key for over 3 seconds in the operation mode, the PL begins to blink in the LED display portion and the lock mode is cleared.



As the panel lock status is stored, it remains valid even after restarting the operation.

Wire connection

■ Basic connection

● -DR (MV-DR) two switch outputs (variable hysteresis) type

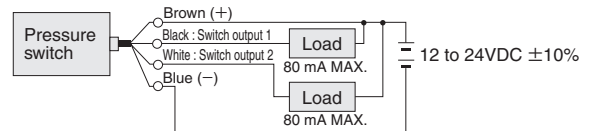

● -DA (MV-DA)

One switch output (variable hysteresis) + Analog output type

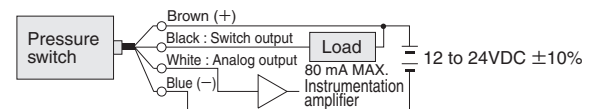

■ Connection with programmable controller

● -DR (MV-DR) two switch outputs (variable hysteresis) type

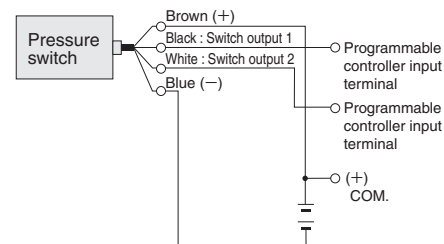

● -DA (MV-DA) one switch output (variable hysteresis) + analog output type

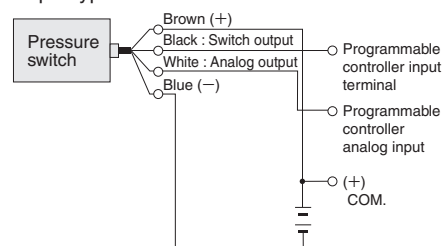

- Note**
1. Use stable DC power for power supply. When unit power supply such as switching power supply is used, ground the F.G. terminal.
 2. Be aware with lead wire color for connection. Improper connection may lead to malfunction and damage.
 3. Do not short circuit the switch output terminal with other terminals, or connect low resistance load (current over 80 mA). Failure to do so creates the internal circuit to be damaged.
 4. For inductive load such as electromagnetic relay, etc., use protective diode for surge suppression.

Handling Instructions and Precautions



Pressure sensor

- EA MSU vacuum sensor head
- ER MSU compound pressure sensor head

1. Pressure sensor circuit diagram

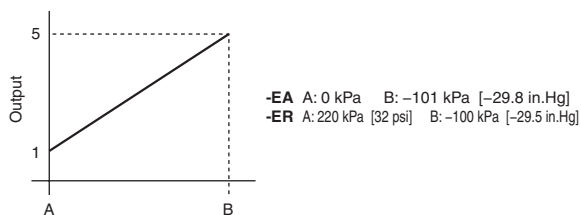
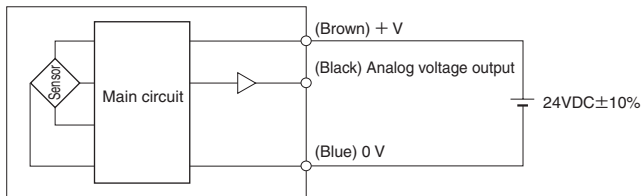

2. Use the pressure sensor for equipment with input impedance over 10 k Ω .
3. Do not apply excessive pulling force etc. to the pressure sensor cable.
4. The pressure sensor is for analog output only. When switch output is necessary, a controller for the pressure sensor is required separately. Prepare our multi-channel, multi-sensor controller (MSU-□) separately.

Attention

- ① Exterior color of pressure sensor heads will be changed from white to black. There is no change in performance.
- ② The body color, and the design of the Multi-Channel, Multi-Sensor Controller will be modified.

Air consumption, vacuum, and vacuum flow rate

●FME05

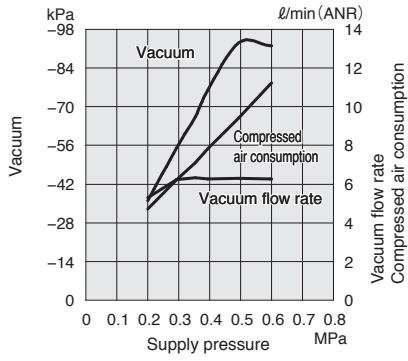

●FME07

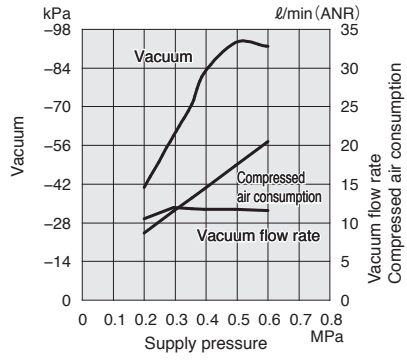

●FME10

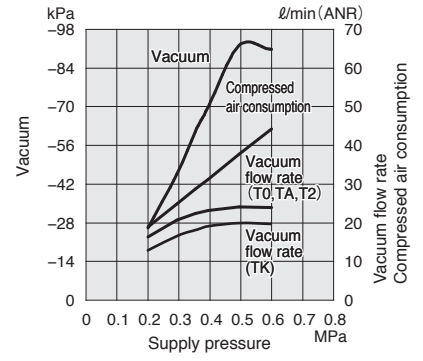

●FME05L

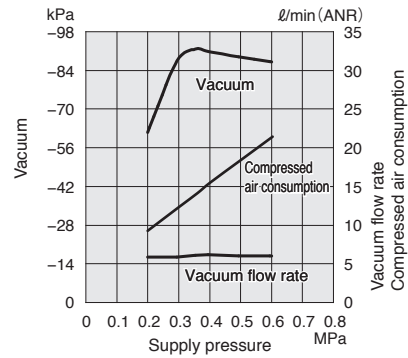

●FME07L

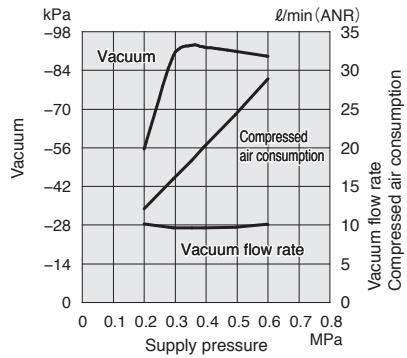

●FME10L

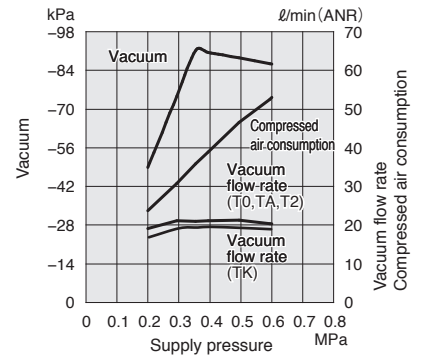

Flow rate characteristics

●FME05

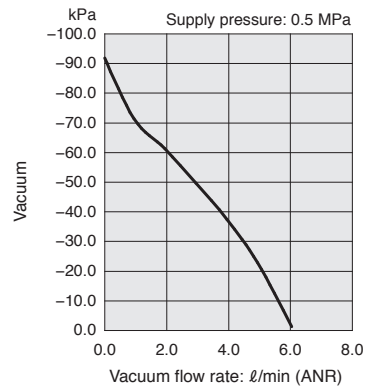

●FME07

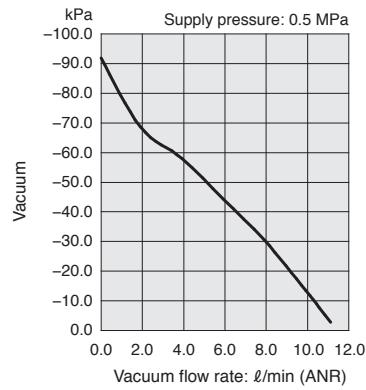

●FME10

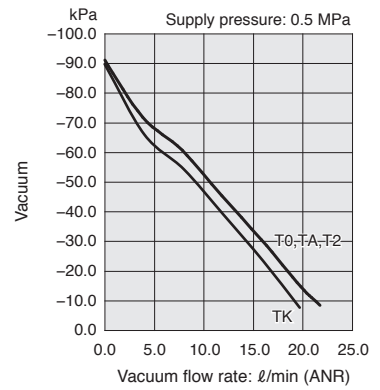

●FME05L

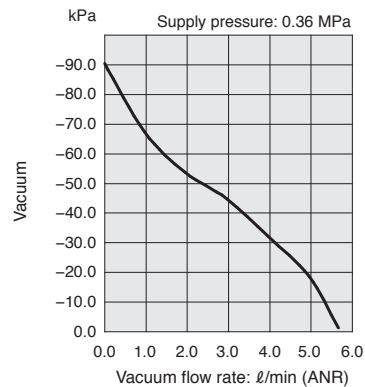

●FME07L

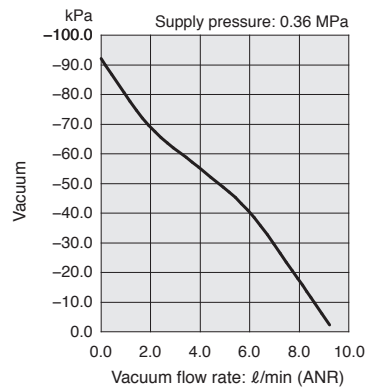

●FME10L

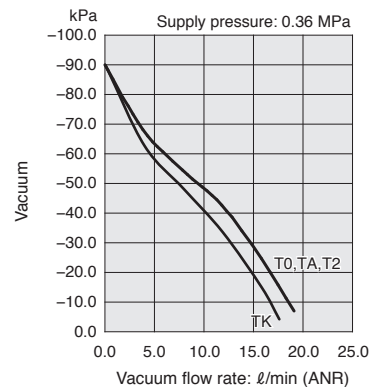

Calculation method of micro ejector response time

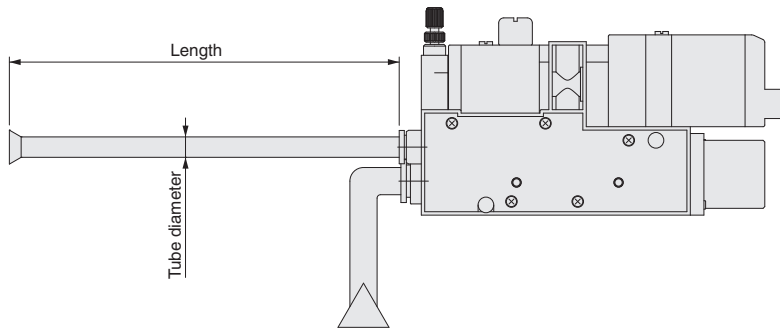

Calculate the lifting time with the following equation and a constant shown in the table, and make selection allowing enough margin.

$$T = \left(\frac{L}{C}\right)^a$$

L: Vacuum piping volume [ℓ]

C: Constant made by vacuum

a: Index by nozzle diameter

T: Reach time [s]

Basic model	C: Constant made by vacuum					a Index
	-40 kPa [-11.82 in.Hg]	-53.3 kPa [-15.74 in.Hg]	-66.7 kPa [-19.70 in.Hg]	-80 kPa [-23.63 in.Hg]	-85 kPa [-25.11 in.Hg]	
FME05 (L)	0.23	0.12	0.065	0.035	0.025	0.98
FME07 (L)	0.42	0.25	0.14	0.08	0.055	0.98
FME10 (L)	0.77	0.46	0.29	0.16	0.1	0.94

Ex:

- Calculate the piping volume.

Calculate the piping volume from the vacuum generation port to the vacuum pad.

When the vacuum side piping is $\phi 4$ [0.157 in.] \times $\phi 2.5$ [0.098 in.] (outer diameter \times inner diameter), length of 50 cm [19.7 in.], and reached degree of vacuum -80 kPa [-23.63 in.Hg] for **FME05**

$$L = 0.0025 [\ell] \left(\frac{\pi \times 0.25^2}{4} \times 50 \div 1000 \right) [0.15 \text{ in}^3]$$

$$C = 0.035$$

$$a = 0.98$$

$$T = \left(\frac{0.0025}{0.035}\right)^{0.98}$$

$$T = 0.08 [\text{s}]$$

Guide to specialized products

Vacuum supply side NO type ejector

● FME□-TA-□-005W

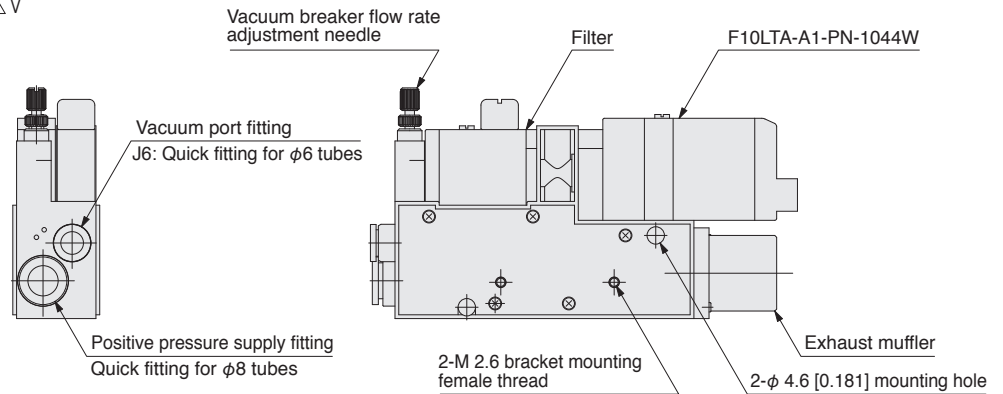
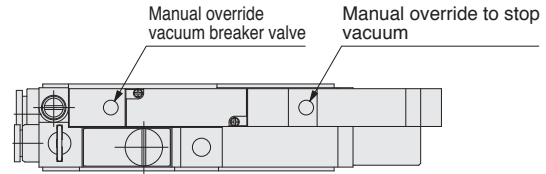
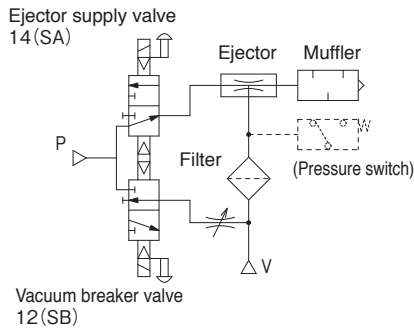

Vacuum supply side self holding type ejector

● FME07-T0-J4-SH-003W

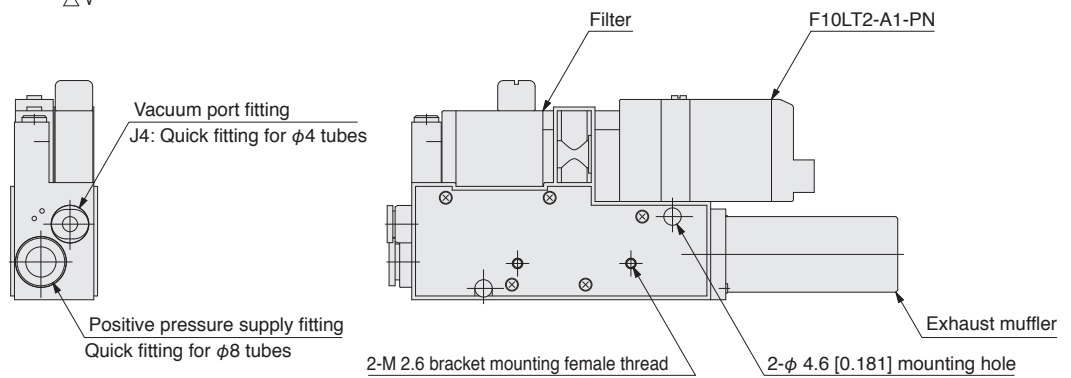
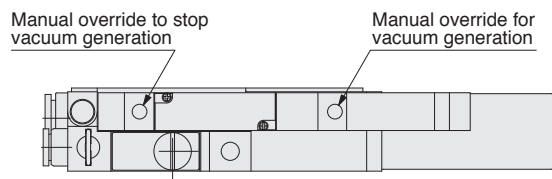
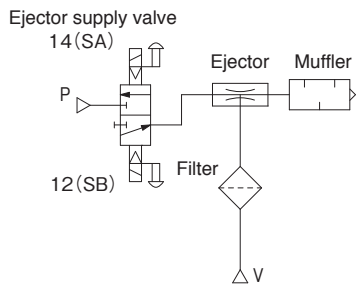

Direct piping type ejector

● FME-006W

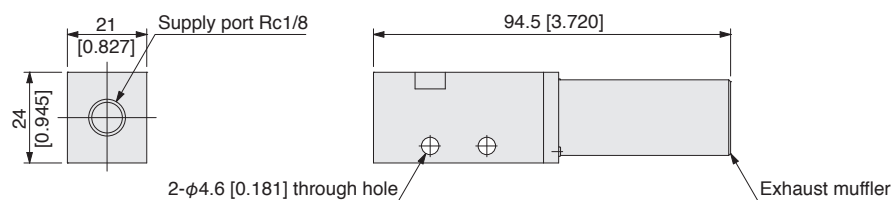
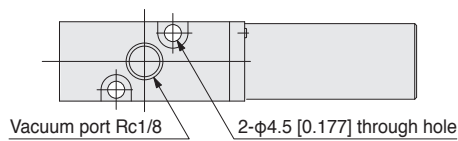

Limited Warranty

KOGANEI CORP. warrants its products to be free from defects in material and workmanship subject to the following provisions.

Warranty Period The warranty period is 180 days from the date of delivery.

Koganei Responsibility If a defect in material or workmanship is found during the warranty period, KOGANEI CORP. will replace any part proved defective under normal use free of charge and will provide the service necessary to replace such a part.

Limitations

- This warranty is in lieu of all other warranties, expressed or implied, and is limited to the original cost of the product and shall not include any transportation fee, the cost of installation or any liability for direct, indirect or consequential damage or delay resulting from the defects.

- KOGANEI CORP. shall in no way be liable or responsible for injuries or damage to persons or property arising out of the use or operation of the manufacturer's product.

- This warranty shall be void if the engineered safety devices are removed, made inoperative or not periodically checked for proper functioning.

- Any operation beyond the rated capacity, any improper use or application, or any improper installation of the product, or any substitution upon it with parts not furnished or approved by KOGANEI CORP., shall void this warranty.

- This warranty covers only such items supplied by KOGANEI CORP. The products of other manufacturers are covered only by such warranties made by those original manufacturers, even though such items may have been included as the components.

The specifications are subject to change without notice.

URL <http://www.koganei.co.jp>

E-mail: overseas@koganei.co.jp



KOGANEI CORPORATION

OVERSEAS DEPARTMENT

3-11-28, Midori-cho, Koganei City, Tokyo 184-8533, Japan
Tel: (+81)42-383-7271 Fax: (+81)42-383-7276

KOGANEI INTERNATIONAL AMERICA, INC.

48860 Milmont Drive, Suite 108C Fremont, CA 94538, U.S.A.
Tel: (+1)510-744-1626 Fax: (+1)510-744-1676

SHANGHAI KOGANEI INTERNATIONAL TRADING CORPORATION

RM 2606-2607, Tongda Venture Building No. 1, Lane 600, Tianshan Road, Shanghai, China
Tel: (+86)021-6145-7313 Fax: (+86)021-6145-7323

TAIWAN KOGANEI TRADING CO., LTD

Rm. 2, 16F., No. 88, Sec. 2, Zhongxiao E. Rd., ZhongZheng Dist., Taipei City 10050, Taiwan (ROC)
Tel: (+886)02-2393-2717 Fax: (+886)02-2393-2719

KOGANEI KOREA CO., LTD

A-3001, Heungdeok IT Valley Bldg., Heungkeok 1-ro, Giheung-gu, Yongin-si, Gyeonggi-do, 446-908, KOREA
Tel: (+82)31-246-0414 Fax: (+82)31-246-0415

KOGANEI (THAILAND) CO., LTD

555 Rasa Tower 1, Unit 1207, 1202, 12th floor, Phaholyothin Road, Chomphon, Chatuchak, Bangkok 10900 Thailand
Tel: (+66)02-513-1228 Fax: (+66)02-513-1232

KOGANEI ASIA PTE. LTD.

69 Ubi Road 1, #05-18 Oxley Bizhub Singapore 408731
Tel: (+65)6293-4512 Fax: (+65)6293-4513