

**POWERFUL & LOW POWER CONSUMPTION**

# **SOLENOID VALVES 010 SERIES**

The Solenoid Valves 010 series achieves high reliability, powerful action, and low current with a thin-body 10mm [0.394in.] valve width.

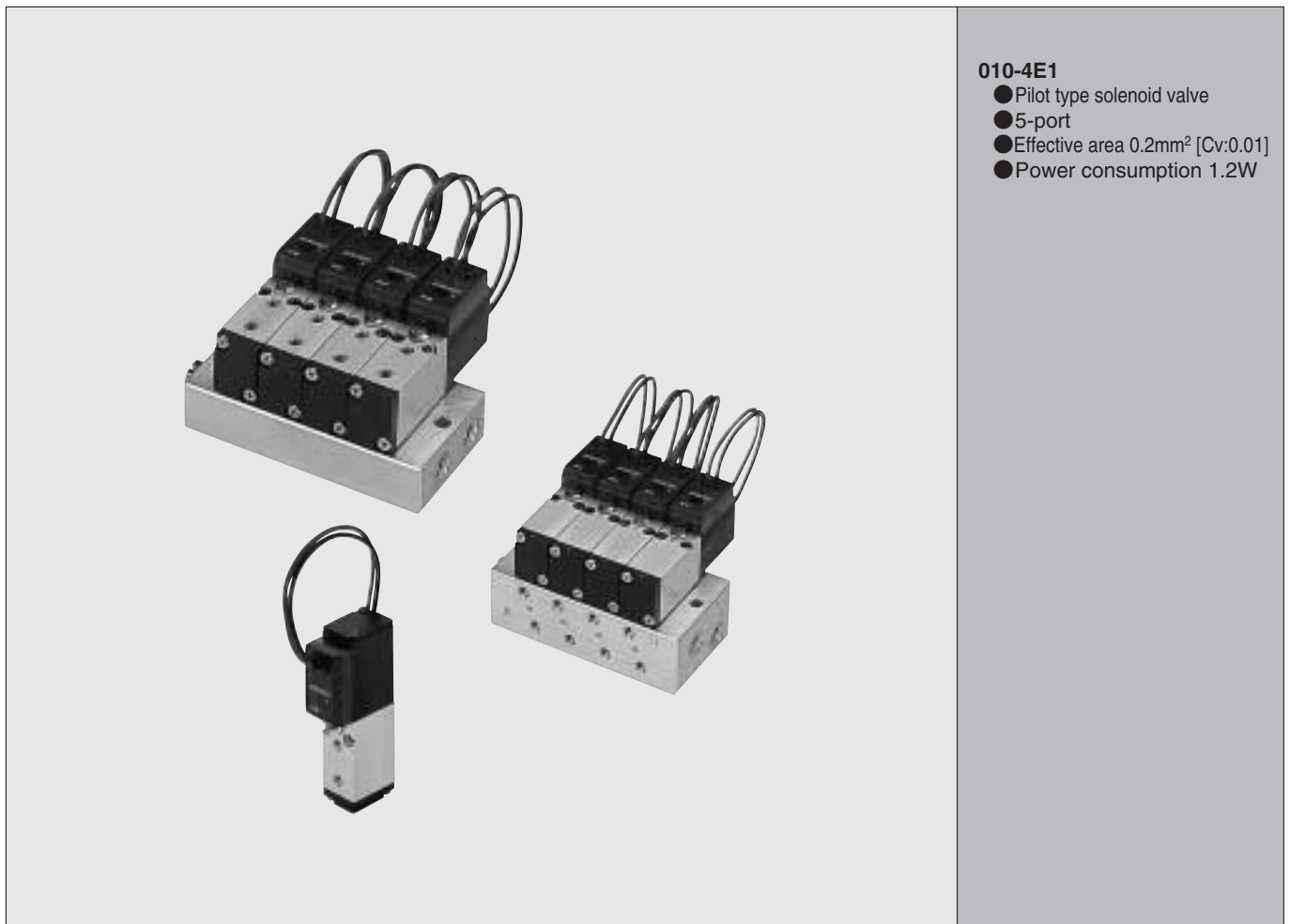

All of these highly reliable 5-port valves incorporate flywheel diodes for surge suppression as a standard feature, to ensure highly reliable operation.

Capable of mounting valves on the manifolds for up to 20 units, this series is the optimum response to customers' requirements for both economy and diversity, enabling operation for double acting cylinders up to  $\phi$  16 [0.630in.] bore.



# Basic Models and Configuration

## Single unit

Pilot type solenoid valve	
010-4E1	
5-port	
Direct piping	 <p>Single solenoid</p> <p><b>010-4E1</b></p>
Sub-base piping	 <p>Single solenoid</p> <p><b>A010-4E1-25</b></p>

SOLENOID VALVES 010 SERIES

## Manifold

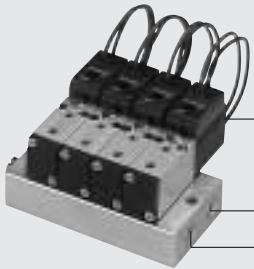
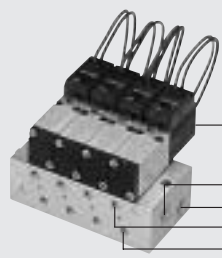
010-4E1	
Small sized manifold for 5-port valves	<div style="display: flex; justify-content: space-around;"> <div style="text-align: center;"> <p><b>010MB□F</b>—F type (P, R) manifold</p>  <p>010-4E1</p> <p>1(P)</p> <p>3, 5(R)</p> </div> <div style="text-align: center;"> <p><b>010MB□A</b>—A type (all port) manifold</p>  <p>A010-4E1</p> <p>3, 5(R)</p> <p>1(P)</p> <p>2(B)</p> <p>4(A)</p> </div> </div>

# SOLENOID VALVES

## 010 SERIES

### Basic Models and Valve Functions

Item	Basic model	Direct piping, F type manifold	Sub-base piping, A type manifold
		010-4E1	A010-4E1 <sup>Note</sup>
Number of positions		2 positions	
Number of ports		5 ports	
Valve function		Single solenoid	

Remark: For optional specifications and order code, see p.65.

Note: A010-4E1, except one with a sub-base, is for A type manifolds only. It cannot be used as a single unit.

### Specifications

Item	Basic model	Direct piping, F type manifold	Sub-base piping, A type manifold
		010-4E1	A010-4E1
Media		Air	
Operation type		Internal pilot type	
Effective area [Cv] <sup>Note1</sup>	mm <sup>2</sup>	1(P)→4(A) 0.2 [0.01]	4(A)→5(R1), 2(B)→3(R2) 0.3 [0.02]
Port size <sup>Note2</sup>		M3×0.5	
Lubrication		Not required	
Operating pressure range	MPa {kgf/cm <sup>2</sup> } [psi.]	0.15~0.7 {1.5~7.1} [22~102]	
Proof pressure	MPa {kgf/cm <sup>2</sup> } [psi.]	1.05 {10.7} [152]	
Response time <sup>Note3</sup>	ms	DC5V, DC12V	4/8 or below
ON/OFF		DC6V, DC24V	4/8 or below
Maximum operating frequency	Hz	5	
Minimum time to energize for self holding	ms	—	
Operating temperature range (atmosphere and media)	°C [°F]	5~50 [41~122]	
Shock resistance	m/s <sup>2</sup> {G}	1373.0 {140.0} (Axial direction 392.3 {40.0})	
Mounting direction		Any	

Notes: 1. For details, see the effective area on p.64.

2. For details, see the port size on p.64.

3. Values when air pressure is 0.5MPa {5.1kgf/cm<sup>2</sup>} [73psi.].

### Solenoid Specifications

Item	Rated voltage	DC5V	DC6V	DC12V	DC24V
	Type		With built-in flywheel diodes for surge suppression		
Operating voltage range	DC V	4.5~5.5 (5±10%)	5.4~6.6 (6±10%)	10.8~13.2 (12±10%)	21.6~26.4 (24±10%)
Current (Power consumption when rated voltage is applied)	mA (W)	246 (1.2)	201 (1.2)	103 (1.2)	52 (1.2)
Maximum allowable leakage current	mA	30	25	15	5
Insulation resistance	MΩ	Over 100			
Wiring type <sup>Note</sup>	Standard	Grommet type			
	Optional	Plug connector type			
Lead wire length <sup>Note</sup>		300 mm [11.8in.]			
Color of lead wire		Green (+) Black (-)	Blue (+) Black (-)	Brown (+) Black (-)	Red (+) Black (-)
Color of LED indicator		Red			
Surge suppression (as standard)		Flywheel diode			

Note: See made to order on p.65.

## Flow Rate

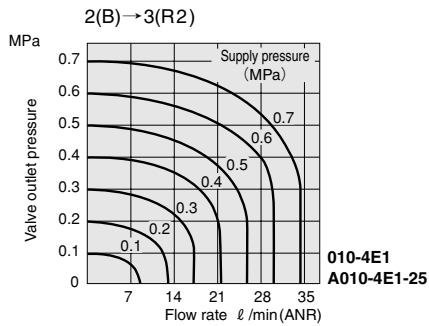
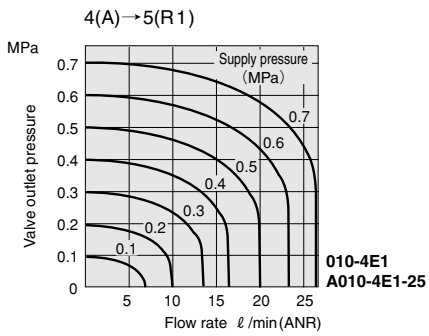
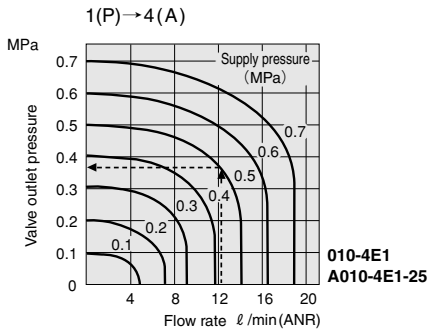

1MPa = 145psi., 1 l /min = 0.0353ft.<sup>3</sup>/min

### How to read the graph (For 1(P)→4(A))

When the supply pressure is 0.5MPa [73psi.] and flow rate is 12 l /min [0.42ft.<sup>3</sup>/min] (ANR), the valve outlet pressure becomes 0.36MPa [52psi.].

## Effective Area [Cv]

mm<sup>2</sup>

Basic model	Standard (Single valve)	Remarks
<b>010-4E1</b>	1(P)→4(A) 0.2 [0.01] 4(A)→5(R1) 0.3 [0.02] 2(B)→3(R2) 0.4 [0.02]	<ul style="list-style-type: none"> <li>● For the case with quick fitting TSH4-M3M attached to the 1(P), 4(A), and 2(B) ports.</li> <li>● Same values as for the case with quick fitting TSH4-M3M attached to the 4(A) port on F type manifold.</li> </ul>
<b>A010-4E1</b>	1(P)→4(A) 0.2 [0.01] 4(A)→5(R1) 0.3 [0.02] 2(B)→3(R2) 0.4 [0.02]	<ul style="list-style-type: none"> <li>● For the case with quick fitting TSH4-M5M attached to the 1(P) port and quick fitting TSH4-M3M attached to the 4(A) port on A type manifold.</li> </ul>

## Solenoid Valve Mass

g [oz.]

Basic model	Mass
<b>010-4E1</b>	20 [0.71]
<b>A010-4E1</b>	20 [0.71] (38 [1.34])

Remark: Figures in parentheses ( ) are the mass with sub-base: -25.

## Manifold Mass

g [oz.]

Manifold model	Mass calculation of each unit (n=number of units)	Block-off plate
<b>010MB□F</b>	(8.5×n)+13 [(0.300×n)+0.46]	3 [0.11]
<b>010MB□A</b>	(13.5×n)+15 [(0.476×n)+0.53]	3 [0.11]

## Solenoid Valve Port Size

Basic model	Port	Port specification	Port size
<b>010-4E1</b> <sup>Note</sup>	1(P), 4(A), 2(B)	Female thread	M3×0.5
<b>A010-4E1-25</b>	1(P)	Female thread	M5×0.8
	4(A), 2(B)	Female thread	M3×0.5
	3, 5(R)	Female thread	M5×0.8

Note: The 3(R2) and 5(R1) ports are 1.2mm diameter holes, not to be used for connecting.

## Manifold Port Size

Manifold model	Port	Location of piping port	Port size
<b>010MB□F</b>	1(P)	Manifold	M5×0.8
	4(A), 2(B)	Valve	M3×0.5
	3, 5(R)	Manifold	M5×0.8
<b>010MB□A</b>	1(P)	Manifold	M5×0.8
	4(A), 2(B)		M3×0.5
	3, 5(R)		M5×0.8

# 010 Series Solenoid Valve Order Code

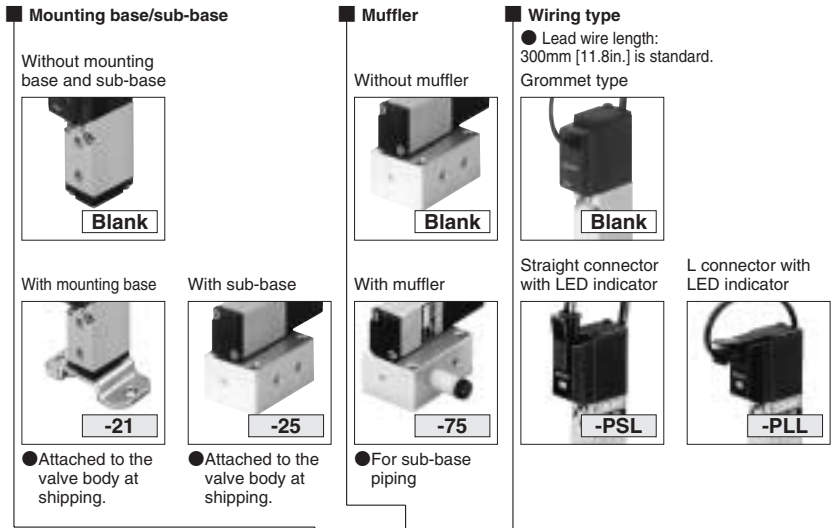

## Solenoid Valve Order Code

		Basic model			Voltage	
Direct piping	5-port single solenoid	<b>010-4E1</b>	-21	-PSL	DC5V, DC6V	
Sub-base piping	5-port single solenoid	<b>A010-4E1</b> <sup>Note</sup>	-25	-75	-PLL	DC12V, DC24V

Note : Cannot be used as a single unit.

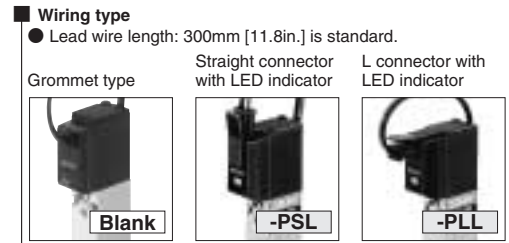

## Manifold Order Code

		Manifold model Number of units	Station	Basic model	Voltage		
5-port single solenoid	<b>010MB</b>	2 ⋮ 20	F	stn. <input type="checkbox"/>	-010-4E1	-PSL	DC5V, DC6V
			A	stn. <input type="checkbox"/>	-A010-4E1		

● Valve mounting location from the left-hand side when facing the 4(A), 2(B) ports. (□ : 1~20)

● Specify the valve type for each station.  
● Enter -BP when closing a station with a block-off plate without mounting a valve.

## Additional Parts (To be ordered separately)



● For sub-base piping



● **010** MB **F** -BP  
 F— For F type manifold  
 A— For A type manifold  
 010—For 010M

## Made to Order

Grommet type with LED indicator

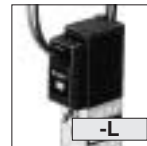

● -L

Lead wire length



● For plug connector  
 ● Length -1L: 1000 [39in.] (mm)  
 -3L: 3000 [118in.]

Locking protruding type manual override



● For 010-4E1, A010-4E1

**5-port**

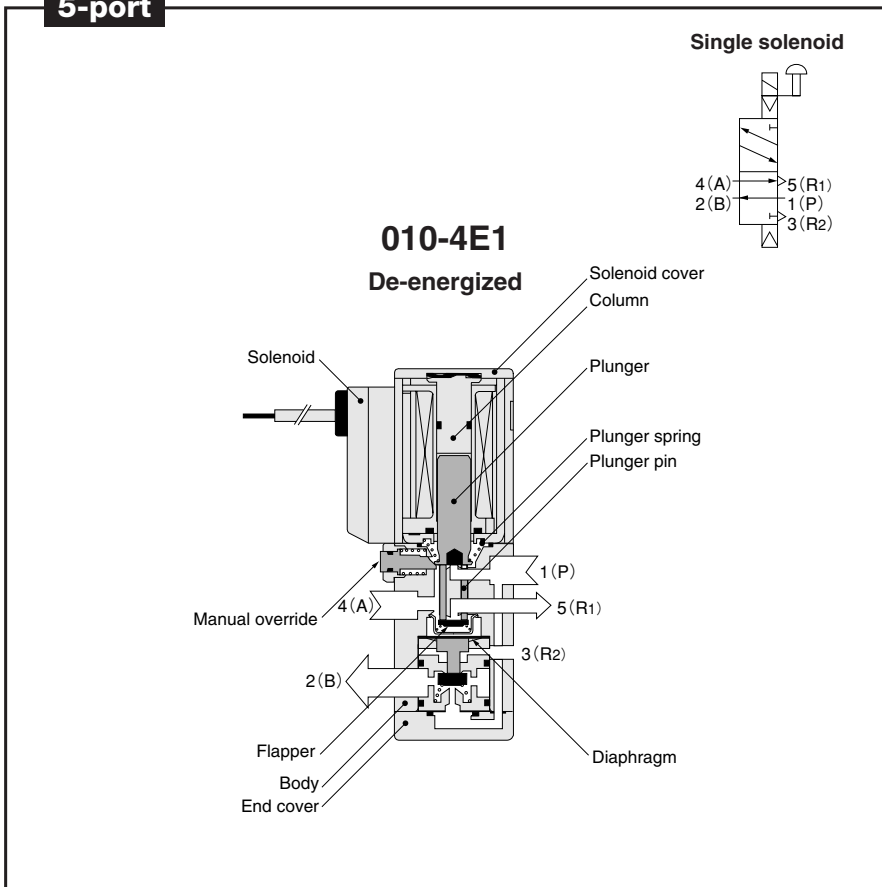

**Major Parts and Materials**

	Parts	Materials
Valve	Body	Aluminum alloy (anodized)
	Stem	Aluminum alloy (anodized)
	Flapper	Synthetic rubber
	Mounting base	Steel (zinc plated)
	Sub-base	Aluminum alloy (anodized)
	Plunger Column	Magnetic stainless steel
Manifold	Body	Aluminum alloy (anodized)
	Block-off plate	Steel (nickel plated)
	Seal	Synthetic rubber

# Dimensions of Solenoid Valve (mm)

## 010-4E1

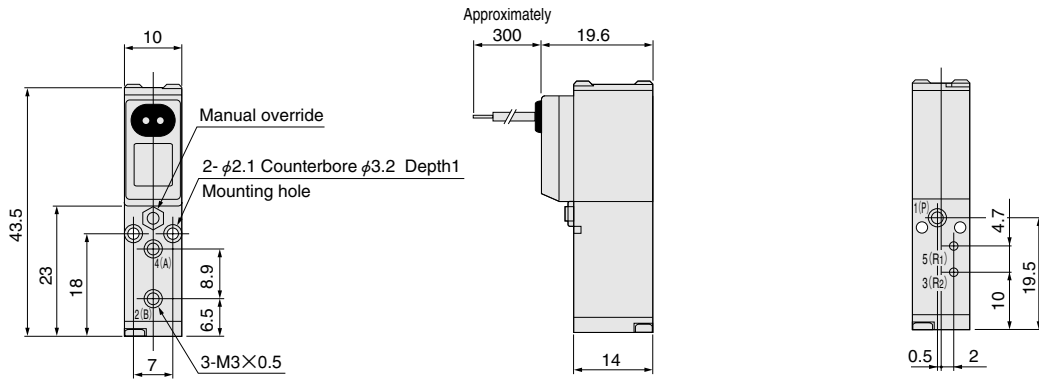

## A010-4E1-25

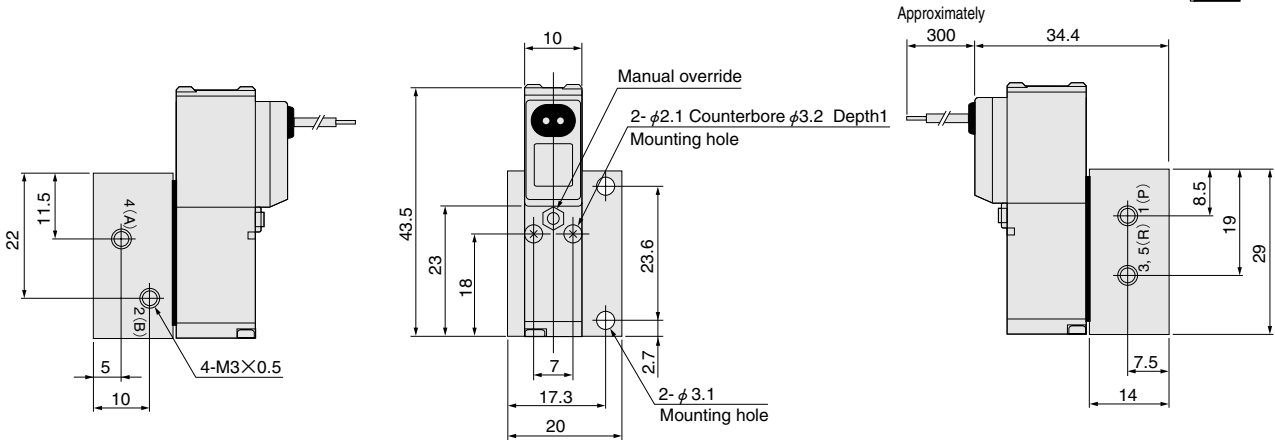

# Options

● Mounting base: **-21**

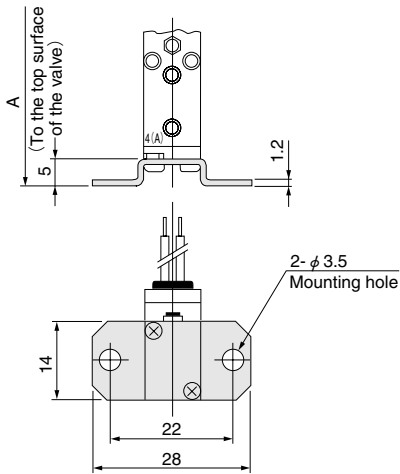

● Solenoid with straight connector: **-PSL**

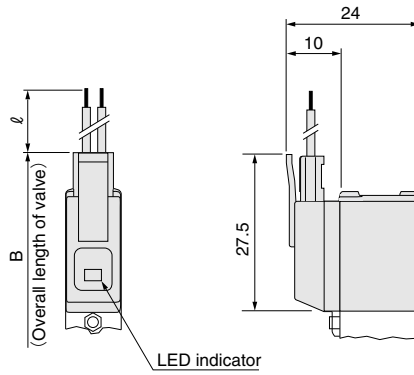

● Muffler: **-75**  
(Only for A010-4E1-25)

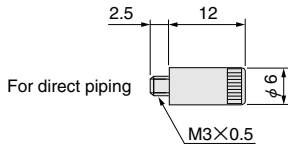
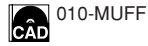

● Solenoid with L connector: **-PLL**

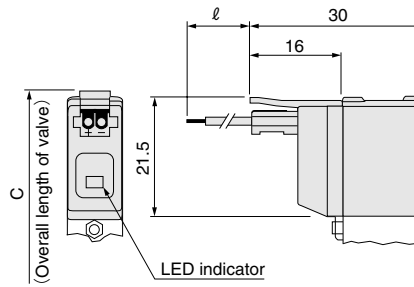

Model	Code	A	B	C	D
010-4E1		48.5	50.5	44.5	43.5

## Made to Order

● Locking protruding type manual override: **-33**

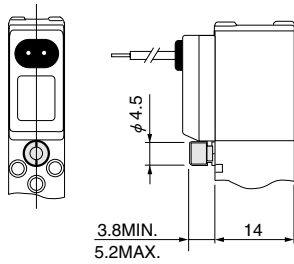
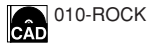

● Grommet type with LED indicator: **-L**

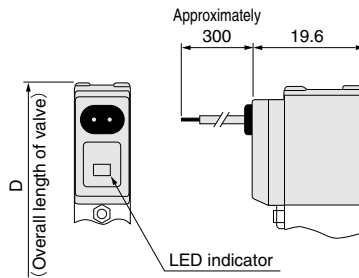

Model	Code	ℓ (Lead wire length)
-PSL, -PLL, -L	(standard length)	300
Made to order	-1L	1000
	-3L	3000



# Dimensions of Manifold (mm)

## 010MB□F

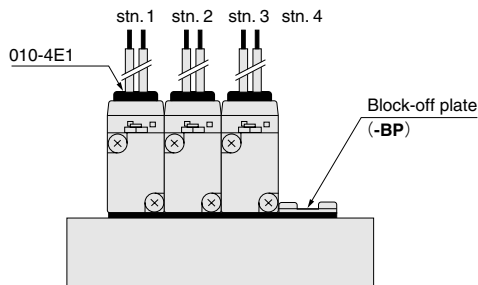
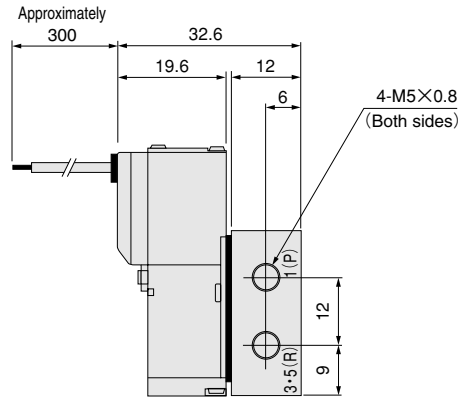
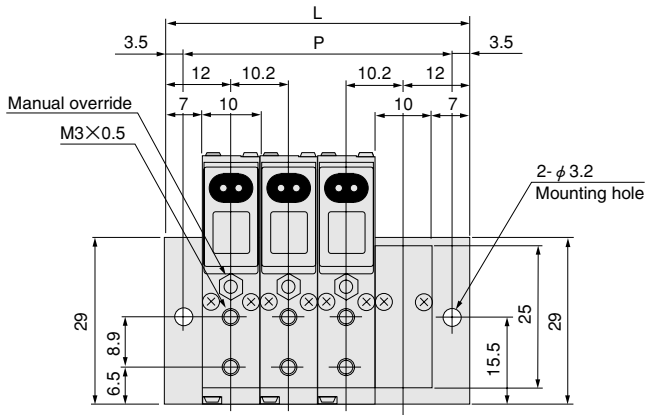

### Unit dimensions

Model	P	L	Model	P	L
010MB2F	27.2	34.2	010MB12F	129.2	136.2
3F	37.4	44.4	13F	139.4	146.4
4F	47.6	54.6	14F	149.6	156.6
5F	57.8	64.8	15F	159.8	166.8
6F	68.0	75.0	16F	170.0	177.0
7F	78.2	85.2	17F	180.2	187.2
8F	88.4	95.4	18F	190.4	197.4
9F	98.6	105.6	19F	200.6	207.6
10F	108.8	115.8	20F	210.8	217.8
11F	119.0	126.0	—	—	—

For wiring options and made to order, see p.68.

# Dimensions of Manifold (mm)

## 010MB□A



SOLENOID VALVES 010 SERIES

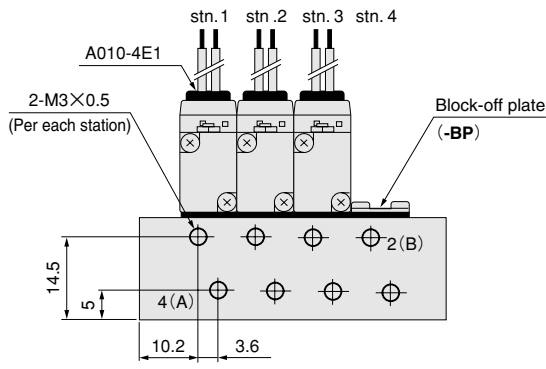
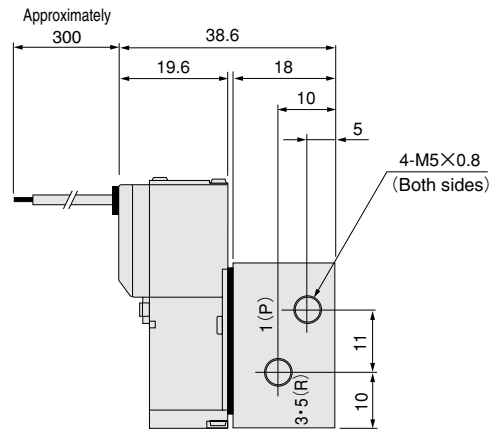
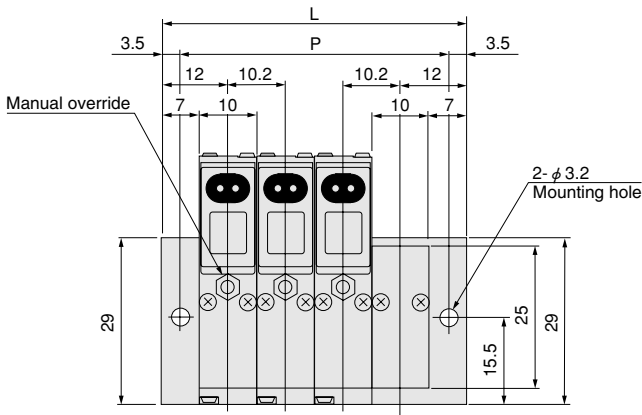

### Unit dimensions

Model	P	L	Model	P	L
010MB2A	27.2	34.2	010MB12A	129.2	136.2
3A	37.4	44.4	13A	139.4	146.4
4A	47.6	54.6	14A	149.6	156.6
5A	57.8	64.8	15A	159.8	166.8
6A	68.0	75.0	16A	170.0	177.0
7A	78.2	85.2	17A	180.2	187.2
8A	88.4	95.4	18A	190.4	197.4
9A	98.6	105.6	19A	200.6	207.6
10A	108.8	115.8	20A	210.8	217.8
11A	119.0	126.0	—	—	—

For wiring options and made to order, see p.68.

# Handling Instructions and Precautions



## Solenoid

### Internal circuit

● DC5V, DC6V, DC12V, DC24V

### Standard solenoid (Surge suppression)

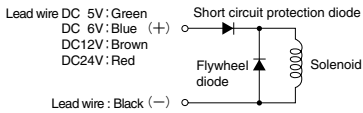

### Solenoid with LED indicator (Surge suppression)

Order code: -PSL, -PLL

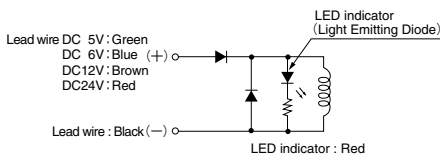

- Cautions:**
1. Do not apply megger between the lead wires.
  2. The DC solenoid will not short circuit even if the wrong polarity is applied, but the valve will not operate.
  3. Leakage current inside the circuit could result in failure of the solenoid valve to return, or in other erratic operation. Always use it within the range of the allowable leakage current. If circuit conditions, etc. cause the leakage current to exceed the maximum allowable leakage current, consult us.



## Plug connector

### Attaching and removing plug connector

Use fingers to insert the connector into the pin, push it in until the lever claw latches onto the protruded section of the connector housing, and complete the connection.

To remove the connector, squeeze the lever along with the connector, lift the lever claw up from the protruded section of the connector housing, and pull it out.

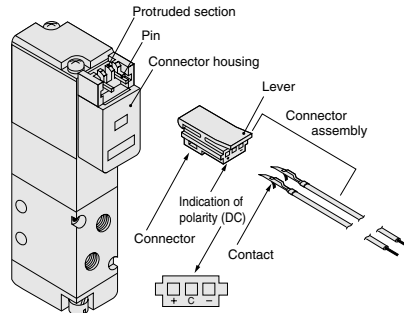

※ Illustration shows the 110 series.

### Crimping of connecting lead wire and contact

To crimp lead wires into contacts, strip off 4mm [0.16in.] of the insulation from the end of the lead wire, insert it into the contact, and crimp it. Be sure to avoid catching the insulation on the exposed wire crimping section.

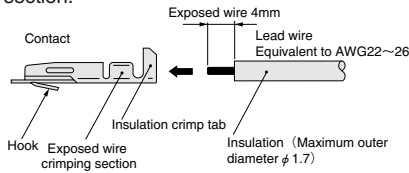

- Cautions:**
1. Do not pull hard on the lead wire.
  2. Always use a dedicated tool for crimping of connecting lead wire and contact.  
Contact: Model 702062-2M  
Manufactured by Sumiko Tech, Inc.  
Crimping tool: Model F1-702062  
Manufactured by Sumiko Tech, Inc.

### Attaching and removing contact and connector

Insert the contact with lead wire into a plug connector □ hole until the contact hook latches on and is secured to the plug connector. Confirm that the lead wire cannot be easily pulled out.

To remove it, insert a tool with a fine tip (such as a small screwdriver) into the rectangular hole on the side of the plug connector to push up on the hook, and then pull out the lead wire.

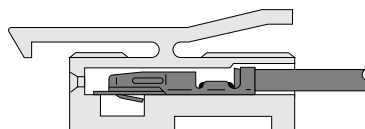

- Cautions:**
1. Do not pull hard on the lead wire. It could result in defective contacts, breaking wires, etc.
  2. If the pin is bent, use a small screwdriver, etc. to gently straighten out the pin, and then complete the connection to the plug connector.



## Manual override

### Non-locking type

To operate the manual override, press it all the way down. The valve works the same as in an energized state as long as the manual override is pushed down, and returns to the rest position upon release.

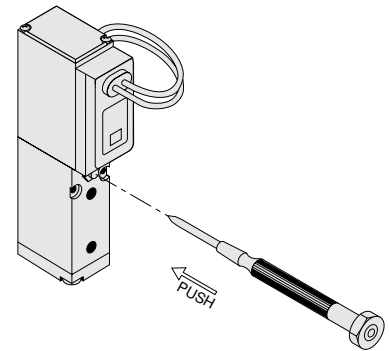

### Locking protruding type

Use a small screwdriver to turn the adjusting knob several times in the clockwise direction, and lock the manual override in place. When locked, turning the adjusting knob several times in the counterclockwise direction releases a spring on the manual override, returns it to the original position, and releases the lock.

For the locking protruding type, when the adjusting knob is not turned, this type acts just like the non-locking type, the valve is energized as long as the manual override is pushed down, and it returns to the rest position upon release.

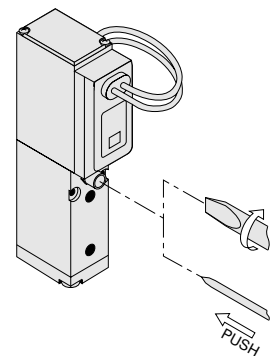

- Cautions:**
1. The 010 series valves are internal pilot type solenoid valves. As a result, the manual override cannot switch the main valve without air supplied from the 1(P) port.
  2. Always release the lock of the locking protruding type manual override before commencing normal operation.
  3. Do not attempt to operate the manual override with a pin or other object having an extremely fine tip. It could damage the manual override button.
  4. Do not turn the adjusting knob more than needed. It could result in defective operation.

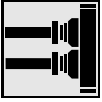

## Fittings

### Recommended fittings

#### 010-4E1

Parts		Connection port	
		4(A), 2(B) port	1(P) port
Quick fitting		TS3-M3M TL3-M3M TLL3-M3M	TS3-M3M TL3-M3M TLL3-M3M
TAC fitting	For urethane tube	BF4BU-M3 BF3BU-M3	BF4BU-M3 BF3BU-M3
	For nylon tube	BF4-M3 BF3.2-M3	BF4-M3 BF3.2-M3
Muffler (for reference)		—	—

#### A010-4E1-25

Parts		Connection port		
		4(A), 2(B) port	1(P) port	3, 5(R) port
Quick fitting		TS3-M3M TS4-M3M TSH4-M3M	TS3-M3M TS4-M3M TSH4-M3M	TS3-M3M TS4-M3M TSH4-M3M
Muffler (for reference)		—	—	KM-03