

Shock absorbers designed by pneumatic cylinder engineers

# Linear Orifice® Shock Absorber KSHJ Series (fixed type)



A wealth of variations  
with sizes from M4 to M48  
18 sizes and 132 models

A wealth of variations  
with sizes from  
10-32UNF to 1 3/4-12UN  
12 sizes and 92 models



**Supports a wide variety of impact masses**  
Supports a wide range of impacting objects, from grams (g) with the M4 size to tons (t) with the M48 size.

**Supports a wide variety of impact speeds**  
Supports maximum impact speeds of 0.8 m/s to 3 m/s.

**Stopper nut not needed**  
Workpieces directly contact the end of the body, so there is no need for mounting a stopper nut. Mounting is easy and saves space.

**Body is entirely threaded**  
Entire body is threaded to maximize the range of installation positions and also improve heat dissipation.  
Note: Except for M4 and M6 (10-32UNF, 1/4-32UNEF) sizes.



**Supports high cycle times**

Reduces the time from impact to end of operation. Even if the workpiece mass and speed changes, our original linear orifice construction automatically adjusts to prevent wasted operation time. Combined with reduced vibration, this contributes to improved productivity.

**Silent design**

Reducing the impact value at collision decreases the noise at workpiece impact.

**Short stroke type**

Perfect in low speed range for shock absorbing in limited spaces.

**Long stroke type**

Making the absorbing stroke longer allows for softer absorption of shocks.

# short stroke type (with hexagon socket)!

Overall length reduced for shock absorbing in tight locations!

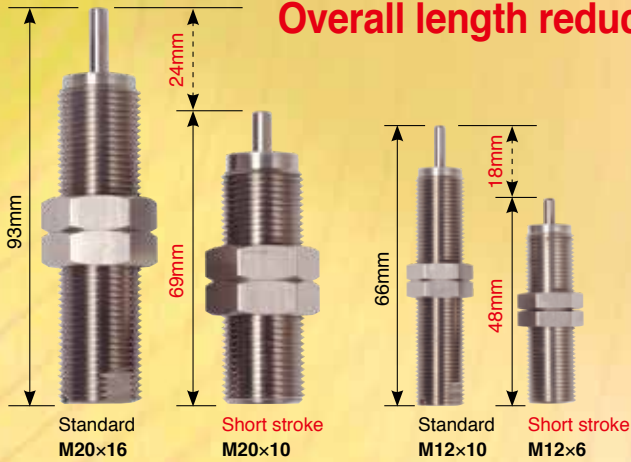

Up to 26% reduction in overall length compared to the same standard threaded body type (for M20). Excellent for absorbing shocks in tight locations as a stopper between 2 cylinder stroke ends because overall short length. Fine position adjustments are easy with more models available with hex sockets.



Short stroke type

## List of KSHJ body thread sizes

[Specifications in mm]

Size	Model			Body thread size × pitch	
	Short stroke	Standard	Long stroke		
M4	—	KSHJ4 × 3	—	M4 × 0.5	—
M6	—	KSHJ6 × 4	KSHJ6 × 6	M6 × 0.75	—
M8	KSHJ8 × 4	KSHJ8 × 5	KSHJ8 × 8	M8 × 0.75	M8 × 1
M10	KSHJ10 × 6	KSHJ10 × 10	KSHJ10 × 15	M10 × 1	—
M12	KSHJ12 × 6	KSHJ12 × 10	—	M12 × 1	—
M14	KSHJ14 × 8	KSHJ14 × 12	—	M14 × 1.5	—
M16	KSHJ16 × 8	KSHJ16 × 15	—	M16 × 1.5	—
M18	—	KSHJ18 × 16	—	M18 × 1.5	—
M20	KSHJ20 × 10	KSHJ20 × 16	—	M20 × 1.5	—
M22	—	KSHJ22 × 25	—	M22 × 1.5	—
M25	—	KSHJ25 × 25	—	M25 × 1.5	M25 × 2
M27	—	KSHJ27 × 25	—	M27 × 1.5	M27 × 3
M30	—	KSHJ30 × 30	—	M30 × 1.5	—
M33	—	KSHJ33 × 30	—	M33 × 1.5	—
M36	—	KSHJ36 × 50	—	M36 × 1.5	—
M42	—	KSHJ42 × 50	KSHJ42 × 70	M42 × 1.5	—
M45	—	KSHJ45 × 50	—	M45 × 1.5	—
M48	—	KSHJ48 × 50	—	M48 × 2	—

[Specifications in inches]

Size	Model		
	Short stroke	Standard	Long stroke
10-32 UNF	—	KSHJ4 × 3-F11	—
1/4-32 UNEF	—	KSHJ6 × 4-F11	KSHJ6 × 6-F11
5/16-32 UNEF	KSHJ8 × 4-F11	KSHJ8 × 5-F11	KSHJ8 × 8-F11
3/8-32 UNEF	KSHJ10 × 6-F11	KSHJ10 × 10-F11	KSHJ10 × 15-F11
7/16-28 UNEF	KSHJ11 × 6-F11	KSHJ11 × 10-F11	KSHJ11 × 15-F11
1/2-20 UNF	KSHJ12 × 6-F11	KSHJ12 × 10-F11	—
9/16-18 UNF	KSHJ14 × 8-F11	KSHJ14 × 12-F11	—
3/4-16 UNF	—	KSHJ18 × 16-F11	—
1-12 UNF	—	KSHJ25 × 25-F11	—
1 1/4-12 UNF	—	KSHJ30 × 30-F11	—
1 3/8-12 UNF	—	KSHJ36 × 50-F11	—
1 3/4-12 UN	KSHJ42 × 50-F11	KSHJ42 × 70-F11	—

# Linear Orifice® Shock Absorbers KSHJ Series



KSHJ

KSHY

KSHP

KSHC

Additional Parts

## Handling instructions and precautions



### General precautions

Cover the unit when mounting it in locations where it might be subject to excessive dust, dripping water, dripping oil, etc. Dents, scratches, water, oil, or dust on the piston rod results in damage and decreases service life.



### Mounting

- Keep the angle of eccentricity, resulting from the load direction and the axis of the shock absorber, under the specified values on pages 17 to 19. If an eccentric load exceeding the specifications is applied, it could result in breakage or impaired returns. If there is concern that an eccentric load exceeding the specified values will be applied, install a guide, or similar mechanism.
- Two or more shock absorbers can be mounted in parallel, to boost absorption capacity. In such an arrangement, however, be careful to ensure that the load is evenly distributed to each shock absorber.
- To adjust the capacity with the stroke, adjust the stopper nut (-S) or add an external stopper.
- If using with a cap, always mount a stopper nut (-S) or an external stopper to ensure that the cap is not subjected to loads at the stroke end. The stopper nut mounting position must not exceed the distance shown in the table below. You can use it without a stopper nut or external stopper, but over the long-term, the stop location changes due to cap deformation and wear.

Model	A	
	mm	in
KSHJ4 × 3C-01,-02 (-F11)	3	0.12
KSHJ6 × 4C-01,-02 (-F11)	4	0.16
KSHJ6 × 6C-01,-02 (-F11)	6	0.24
KSHJ8 × 4C-01,-02,-11,-12 (-F11)	4	0.16
KSHJ8 × 5C-01,-11 (-F11)	5	0.20
KSHJ8 × 8C-01,-02,-11,-12 (-F11)	8	0.31
KSHJ10 × 6C-01,-02 (-F11)	6	0.24
KSHJ11 × 6C-F11-01,-02	—	0.24
KSHJ10 × 10C-01,-02 (-F11)	10	0.40
KSHJ11 × 10C-F11-01,-02	—	0.40
KSHJ10 × 15C-01,-03 (-F11)	15	0.60
KSHJ11 × 15C-F11-01,-03	—	0.60
KSHJ12 × 6C-01,02 (-F11)	6	0.24
KSHJ12 × 10C-01,-02 (-F11)	10	0.40
KSHJ14 × 8C-01,02 (-F11)	8	0.31
KSHJ14 × 12C-01,-02 (-F11)	12	0.47
KSHJ16 × 8C-01,-02	8	—
KSHJ16 × 15C-01,-02	15	—
KSHJ18 × 16C-01,-02 (-F11)	16	0.63
KSHJ20 × 10C-01,-02	10	—
KSHJ20 × 16C-01,-02	16	—
KSHJ22 × 25C-01,-02	25	—
KSHJ25 × 25C-01,-11,-12 (-F11)	25	0.98
KSHJ27 × 25C-01,-02,-11,-12	25	—
KSHJ30 × 30C-01,-02,-03 (-F11)	30	1.18
KSHJ33 × 30C-01,-02,-03	30	—
KSHJ36 × 50C-01,-02,-03 (-F11)	50	1.97
KSHJ42 × 50C-01,-02 (-F11)	50	1.97
KSHJ42 × 70C-01,-02 (-F11)	70	2.76
KSHJ45 × 50C-01,-02	50	—
KSHJ48 × 50C-01,-02	50	—

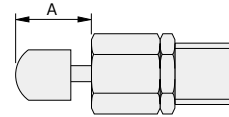

- The small screw on the back end of the shock absorber should never be loosened or removed. Oil may leak out of the shock absorber leading to a loss of functionality and resulting in damage to the equipment and accidents.
- When mounting the shock absorber, always use the following maximum tightening torque guidelines. Tightening using excessive force may result in damage.

Model	Maximum tightening torque	
	N · m	in · lbf
KSHJ4 × 3 (C)-01,-02 (-F11)	0.5	4.43
KSHJ6 × 4 (C)-01,-02 (-F11)	0.85	7.52
KSHJ6 × 6 (C)-01,-02 (-F11)	0.85	7.52
KSHJ8 × 4 (C)-01,-02,-11,-12 (-F11)	2.5	22.12
KSHJ8 × 5 (C)-01,-11 (-F11)	2.5	22.12
KSHJ8 × 8 (C)-01,-02,-11,-12 (-F11)	2.5	22.12
KSHJ10 × 6 (C)-01,-02 (-F11)	6.5	57.53
KSHJ11 × 6 (C)-01,-02	—	57.5
KSHJ10 × 10 (C)-01,-02 (-F11)	6.5	57.53
KSHJ11 × 10 (C)-01,-02	—	57.5
KSHJ10 × 15 (C)-01,-03 (-F11)	6.5	57.53
KSHJ11 × 15 (C)-01,-03	—	57.5
KSHJ12 × 6 (C)-01,02 (-F11)	8.0	70.80
KSHJ12 × 10 (C)-01,-02 (-F11)	8.0	70.80
KSHJ14 × 8 (C)-01,02 (-F11)	12.0	106.21
KSHJ14 × 12 (C)-01,-02 (-F11)	12.0	106.21
KSHJ16 × 8 (C)-01,-02	20.0	—
KSHJ16 × 15 (C)-01,-02	20.0	—
KSHJ18 × 16 (C)-01,-02 (-F11)	25.0	221.28
KSHJ20 × 10 (C)-01,-02	30.0	—
KSHJ20 × 16 (C)-01,-02	30.0	—
KSHJ22 × 25 (C)-01,-02	35.0	—
KSHJ25 × 25 (C)-01,-11,-12 (-F11)	42.0	371.74
KSHJ27 × 25 (C)-01,-02,-11,-12	42.0	—
KSHJ30 × 30 (C)-01,-02,-03 (-F11)	60.0	531.06
KSHJ33 × 30 (C)-01,-02,-03	60.0	—
KSHJ36 × 50 (C)-01,-02,-03 (-F11)	72.0	531.06
KSHJ42 × 50 (C)-01,-02 (-F11)	85.0	637.27
KSHJ42 × 70 (C)-01,-02 (-F11)	85.0	637.27
KSHJ45 × 50 (C)-01,-02	85.0	—
KSHJ48 × 50 (C)-01,-02	120.0	—

Note: The **KSHJ45 × 50(C)-01**, and **-02** use nominal number AN09 mounting nut prescribed in JIS B1554 (nuts for rolling bearings). Use a hook wrench (nominal 58 to 65 or 65 to 70) for tightening.

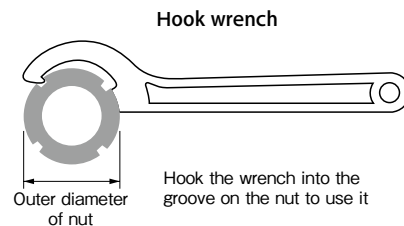

- Ensure that the hardness of the surface directly impacting the piston rod of the shock absorber is over HRC40 hardness (excluding models with cap).
- Be aware that performance and characteristics change depending on the operating temperature.

**How to select shock absorbers**

**1. Confirm the thrust**

Confirm the thrust that is used, and then check the prospective shock absorbers from the table of recommended cylinder bore sizes on page 16. If a shock absorber that is smaller than the recommended shock absorber is used, the shock absorber being used may be damaged in fewer operation cycles than is guaranteed.

**2. Confirm the kinetic energy**

Confirm I and II below, and then check pages 14 to 16 for the selection graphs for prospective shock absorbers from [1. Confirm the thrust]. (\*)

I Impact object mass: m [kg]

II Impact speed: v [m/s]

Because "v" is the impact speed, not the average speed, when using a cylinder,

$$v = m [\text{cylinder stroke}] \div s [\text{operating time}] \times 2$$

Select a model in which I and II fit within the range enclosed by the capacity curves.

If multiple models are applicable, use the model that is closest to both the capacity curves and the operating conditions. The further the model you select is from the capacity curves and the operating conditions, the slower it will tend to be.

**3. Confirm other specifications**

Confirm that such specifications as the maximum operating frequency, maximum absorption capacity per unit of time, angle of eccentricity, and operating temperature range are within the range for the shock absorber that you selected.

\* The value for the kinetic energy, E, can be found by doing the following calculation. However, the shock absorber's capacity for absorption changes depending on the impact speed. When the shock absorber is doing low-speed operations, it has less drag than when it is doing high-speed operations.

The maximum absorption capacity that is noted in the specifications is reached only at the maximum impact speed.

Therefore, do not choose a shock absorber by comparing E to the maximum absorption capacity; confirm the capacity using the selection graph.

$$E = \frac{1}{2} mv^2$$

E: Kinetic energy (J)

m: Impact object mass [kg]

v: Impact speed (m/s)

**Range in the selection graph**

Vertical axis range :

$$\text{Maximum impact speed} \geq v \text{ Impact speed (operating condition)}$$

Horizontal axis range :

$$\text{Shock absorber's maximum absorption capacity at the impact speed (v = m/s)} \geq \text{Kinetic energy (operating condition)}$$

Calculating the thrust energy is not necessary because the size of the shock absorber is limited by the thrust in step 1.

**Koganei's selectable content**

You can also select equipment from Koganei's homepage.

Visit <http://www.koganei.co.jp>.

The results of selections using the method above may differ from the results of selections for the selectable content on our homepage. If this happens, please contact us.

**Example of selecting a shock absorber**

[Operating conditions]

- ① Bore size of the cylinder being used:  $\phi 16$
- ② Cylinder stroke: 100 mm = 0.1 m
- ③ Pressure applied to the cylinder: 0.6 MPa
- ④ Cylinder's operating time: 0.4 s
- ⑤ Impact object mass: 7 kg

**1. Confirm the thrust**

Either calculate or find the thrust in the cylinder thrust table on page 16. The cylinder thrust based on ① and ③ is about 121 N.

Cylinder thrust	100.5N	<	120.6N	<	126N
Cylinder bore size	$\phi 16$		$\phi 16$		$\phi 20$
Applied pressure	0.5MPa		0.6MPa		0.4MPa

As mentioned above, although the cylinder being used is  $\phi 16$ , the pressure applied to the cylinder exceeds 0.5 MPa, so consider the  $\phi 20$  cylinder (lower than 0.4 MPa) and check the table of recommended cylinder bore sizes on page 16.

The following are prospective models.

- KSHJ10×6    • KSHJ10×10    • KSHJ10×15
- KSHJ12×6    • KSHJ12×10
- KSHJ14×8    • KSHJ14×12
- KSHJ16×15

**2. Confirm the kinetic energy**

I The impact object mass m = 7 kg from ⑤

II Find the impact speed, v, from ② and ④.

$$v = \frac{②}{④} = \frac{0.1 \text{ m}}{0.4 \text{ s}} \times 2 = 0.5 \text{ m/s}$$

According to the selection graphs on pages 14 to 16, the shock absorber with the optimum absorption capacity for operating conditions is KSHJ12×6-02.

**● KSHJ10×6 (with hexagon socket) ● KSHJ10×10**

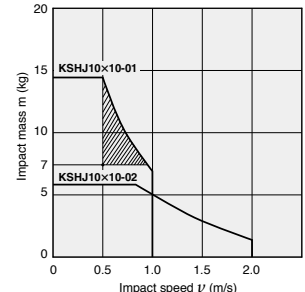
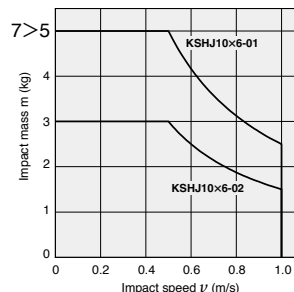

**● KSHJ10×15**

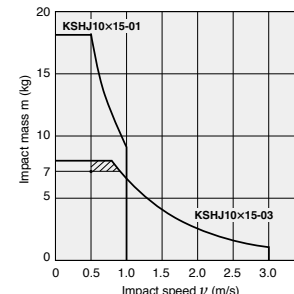

**● KSHJ12×6 (with hexagon socket)**

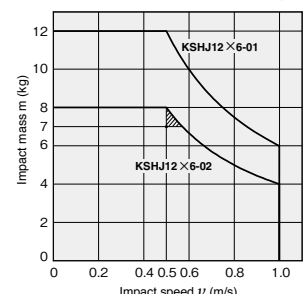

- KSHJ10×6 and 10×10-02 have an insufficient absorption capacity.
- KSHJ10×15-03, 12×6-01....KSHJ12×6-02 come closer to the operating conditions and capacity curves.
- The absorption capacities for all of the other shock absorbers are higher than that of KSHJ12×6-02, so they do not fall within the operating conditions and capacity curves.

**3. Confirm other specifications**

Verify that other operating conditions, such as the maximum operating frequency, maximum absorption capacity per unit of time, angle of eccentricity, and operating temperature range, are within the specified ranges for KSHJ12×6-02.

# Selection Guidelines

## Recommended cylinder bore size

Model	Cylinder bore																		
	φ 4	φ 6	φ 8	φ 10	φ 12	φ 16	φ 20	φ 25	φ 32	φ 40	φ 50	φ 63	φ 80	φ 100	φ 125	φ 140	φ 160	φ 180	φ 200
KSHJ4×3 (-F11)	◇	◎	○																
KSHJ6×4 (-F11)		◇	◎	○															
KSHJ6×6 (-F11)		◇	◎	○															
KSHJ8×4 (-F11)(with hexagon socket)				◇	◎	◎	○												
KSHJ8×5 (-F11)			◇	◎	◎	○													
KSHJ8×8 (-F11)			◇	◎	◎	○													
KSHJ10×6 (-F11)(with hexagon socket)					◇	◎	◎	○											
KSHJ10×10 (-F11)				◇	◎	◎	○												
KSHJ10×15 (-F11)				◇	◎	◎	○												
KSHJ11×6-F11					◇	◎	◎	○											
KSHJ11×10-F11				◇	◎	◎	○												
KSHJ11×15-F11				◇	◎	◎	○												
KSHJ12×6 (-F11)(with hexagon socket)						◇	◎	◎	○										
KSHJ12×10 (-F11)					◇	◎	◎	○											
KSHJ14×8 (-F11)(with hexagon socket)							◇	◎	◎	○									
KSHJ14×12 (-F11)						◇	◎	◎	○										
KSHJ16×8 (with hexagon socket)								◇	◎	◎	○								
KSHJ16×15							◇	◎	◎	○									
KSHJ18×16 (-F11)								◇	◎	○									
KSHJ20×10 (with hexagon socket)									◇	◎	◎	○							
KSHJ20×16									◇	◎	○								
KSHJ22×25										◇	◎	○							
KSHJ25×25 (-F11)										◇	◎	◎	○						
KSHJ27×25										◇	◎	◎	○						
KSHJ30×30 (-F11)											◇	◎	◎	○					
KSHJ33×30											◇	◎	◎	○					
KSHJ36×50 (-F11)												◇	◎	◎	○	○			
KSHJ42×50 (-F11)													◇	◎	◎	○	○		
KSHJ42×70 (-F11)														◇	◎	◎	○	○	
KSHJ45×50															◇	◎	◎	○	○
KSHJ48×50																◇	◎	◎	○

◇ : 0.3 MPa or higher    ◎ : 0.5 MPa or lower    ○ : 0.4 MPa or lower

Note 1: If a shock absorber that is smaller than the recommended shock absorber is used, the shock absorber being used may be damaged in fewer operation cycles than the value that is guaranteed.

Note 2: KSHJ11×6, KSHJ11×10, and KSHJ11×15 have only inch specifications.

## Cylinder thrust

N [lbf.]

Bore size mm [in.]	Pressure area mm <sup>2</sup> [in. <sup>2</sup> ]	Air pressure MPa [psi.]								
		0.1 [15]	0.2 [29]	0.3 [44]	0.4 [58]	0.5 [73]	0.6 [87]	0.7 [102]	0.8 [116]	0.9 [131]
φ 4	12.9 [0.01]	1.3 [0.2]	2.5 [0.6]	3.8 [0.9]	5 [1.1]	6.3 [1.4]	7.5 [1.7]	8.8 [2.0]	10.1 [2.3]	11.3 [2.5]
φ 6	28.3 [0.04]	2.8 [0.6]	5.7 [1.3]	8.5 [1.9]	11.3 [2.5]	14.1 [3.2]	17.0 [3.8]	19.8 [4.5]	22.6 [5.1]	25.4 [5.7]
φ 8	50.3 [0.08]	5 [1.1]	10.1 [2.3]	15.1 [3.4]	20.1 [4.5]	25.1 [5.6]	30.2 [6.8]	35.2 [7.9]	40.2 [9.0]	45.2 [10.2]
φ 10	78.5 [0.12]	7.9 [1.8]	15.7 [3.5]	23.6 [5.3]	31.4 [7.1]	39.3 [8.8]	47.1 [10.6]	55 [12.4]	62.8 [14.1]	70.7 [15.9]
φ 12	113 [0.18]	11.3 [2.5]	22.6 [5.1]	33.9 [7.6]	45.2 [10.2]	56.5 [12.7]	67.9 [15.3]	79.2 [17.8]	90.5 [20.3]	101.8 [22.9]
φ 16	201 [0.31]	20.1 [4.5]	40.2 [9.0]	60.3 [13.6]	80.4 [18.1]	100.5 [22.6]	121 [27.2]	141 [31.7]	161 [36.2]	181 [40.7]
φ 20	314 [0.49]	31.4 [7.1]	62.8 [14.1]	94.2 [21.2]	126 [28.3]	157 [35.3]	188 [42.3]	220 [49.5]	251 [56.4]	283 [63.7]
φ 25	491 [0.76]	49.1 [11.0]	98.2 [22.1]	147 [33.0]	196 [44.1]	245 [55.1]	295 [66.3]	344 [77.3]	393 [88.3]	442 [99.4]
φ 32	804 [1.25]	80.4 [18.1]	161 [36.2]	241 [54.2]	322 [72.4]	402 [90.4]	483 [108.6]	563 [126.6]	643 [144.6]	724 [162.8]
φ 40	1257 [1.95]	126 [28.3]	251 [56.4]	377 [84.8]	503 [113.1]	628 [141.2]	754 [169.5]	880 [197.8]	1005 [225.9]	1131 [254.3]
φ 50	1963 [3.04]	196 [44.1]	393 [40.1]	589 [132.4]	785 [176.5]	982 [220.8]	1178 [264.8]	1374 [308.9]	1571 [353.2]	1767 [397.2]
φ 63	3117 [4.83]	312 [70.1]	623 [63.5]	935 [210.2]	1247 [280.3]	1559 [350.5]	1870 [420.4]	2182 [490.5]	2494 [560.7]	2806 [630.8]
φ 80	5027 [7.80]	503 [113.1]	1005 [102.5]	1508 [339.0]	2011 [452.1]	2513 [564.9]	3016 [678.0]	3519 [791.1]	4021 [904.0]	4524 [1017.0]
φ 100	7854 [12.17]	785 [176.5]	1571 [160.2]	2356 [529.6]	3142 [706.3]	3927 [882.8]	4712 [1059.3]	5498 [1236.0]	6283 [1412.5]	7069 [1589.2]
φ 125	12272 [19.02]	1227 [275.8]	2454 [250.2]	3682 [827.7]	4909 [1103.6]	6136 [1379.4]	7363 [1655.3]	8590 [1931.1]	9817 [2206.9]	11045 [2483.0]
φ 140	15394 [23.86]	1539 [346.0]	3079 [314.0]	4618 [1038.2]	6158 [1384.4]	7697 [1730.4]	9236 [2076.3]	10776 [2422.5]	12315 [2768.5]	13854 [3114.5]
φ 160	20106 [31.16]	2011 [452.1]	4021 [904.0]	6032 [1356.0]	8042 [1808.0]	10053 [2260.0]	12064 [2712.1]	14074 [3164.0]	16085 [3616.1]	18096 [4068.1]
φ 180	25447 [39.44]	2545 [572.1]	5089 [1144.1]	7634 [1716.2]	10179 [2288.3]	12723 [2860.2]	15268 [3432.4]	17813 [4004.5]	20358 [4576.7]	22902 [5148.6]
φ 200	31416 [48.69]	3142 [706.4]	6283 [1412.5]	9425 [2118.8]	12566 [2824.9]	15708 [3531.3]	18850 [4237.6]	21991 [4943.8]	25133 [5650.1]	28274 [6356.3]

# Selection Guidelines

## Cautions for using the selection graphs

1. The selection graphs are calculated with a cylinder operating air pressure of 0.5 MPa.
2. The values in the selection graphs are for room temperature (20 to 25°). Be aware that performance and characteristics change depending on the operating temperature.
3. Select a shock absorber that is as close to, yet within, the capacity line(s).
4. You can select them on the Koganei home page. Go to <http://www.koganei.co.jp>  
The results of selections using our catalog may differ from the results of selections on our homepage.

## ■ Selection graph

### ● KSHJ4×3(-F11)

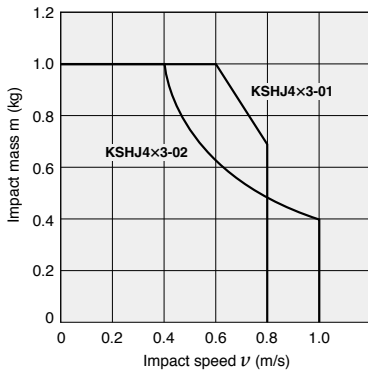

### ● KSHJ6×4(-F11)

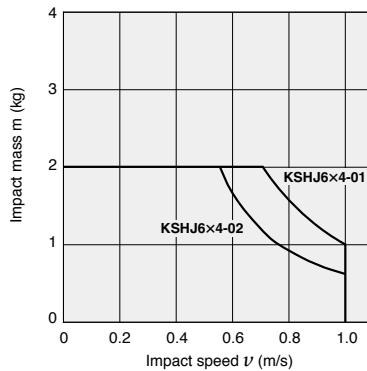

### ● KSHJ6×6(-F11)

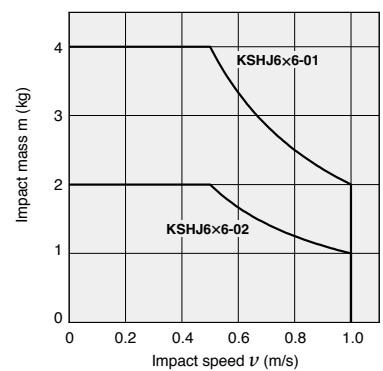

### ● KSHJ8×4(-F11)

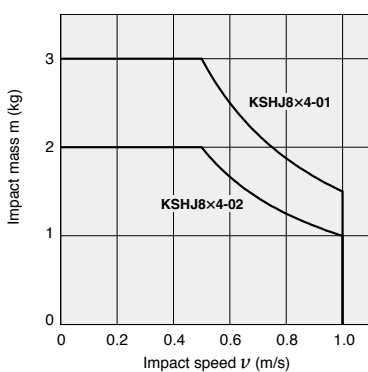

### ● KSHJ8×5(-F11)

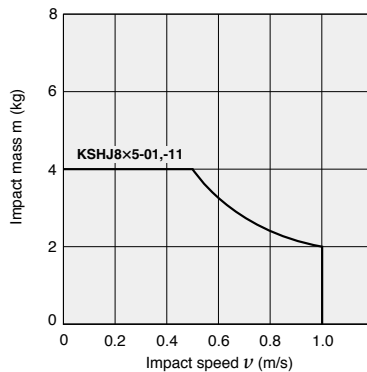

### ● KSHJ8×8(-F11)

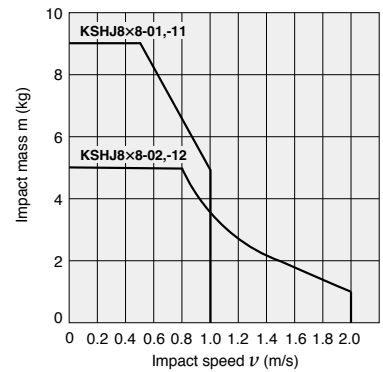

### ● KSHJ10×6(-F11)

### ● KSHJ11×6-F11

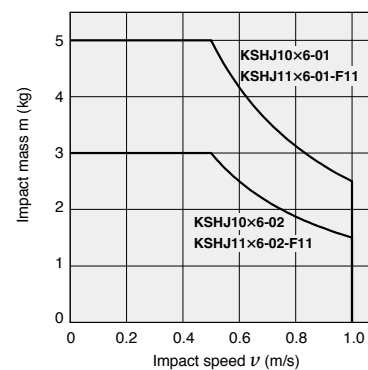

### ● KSHJ10×10(-F11)

### ● KSHJ11×10-F11

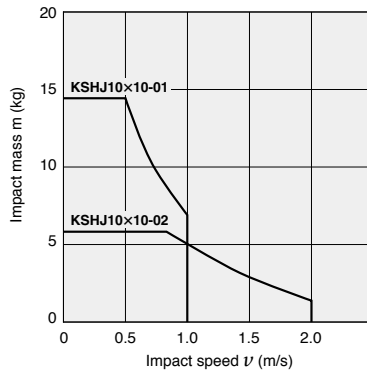

### ● KSHJ10×15(-F11)

### ● KSHJ11×15-F11

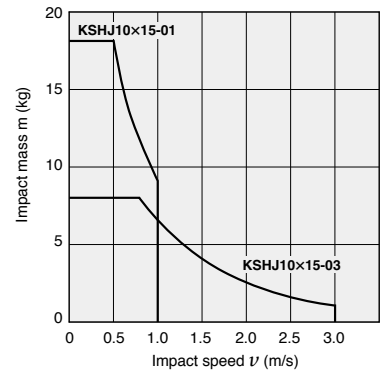

# Selection Guidelines

## • KSHJ12×6(-F11)

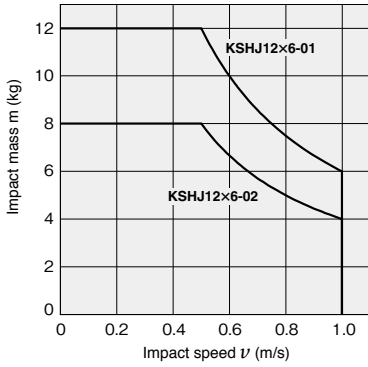

## • KSHJ12×10(-F11)

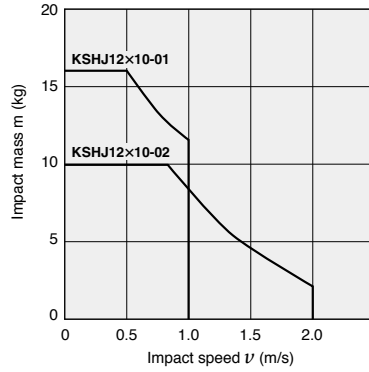

## • KSHJ14×8(-F11)

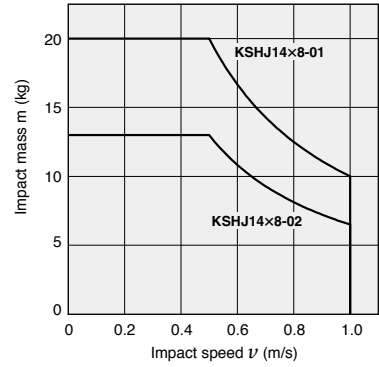

## • KSHJ14×12(-F11)

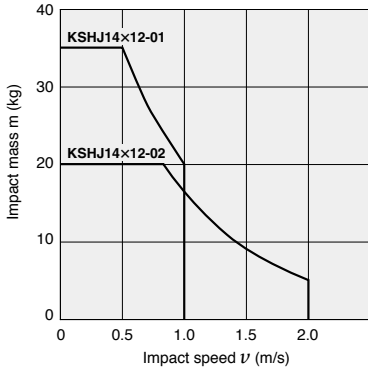

## • KSHJ16×8

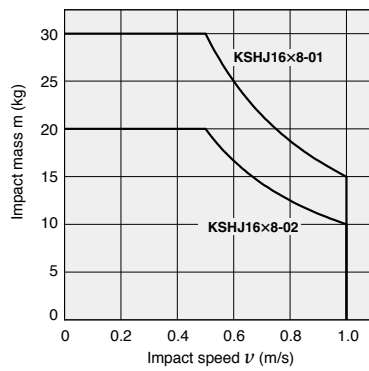

## • KSHJ16×15

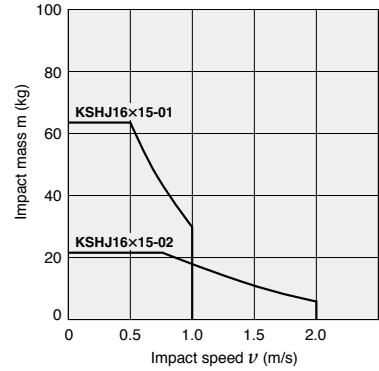

## • KSHJ18×16(-F11)

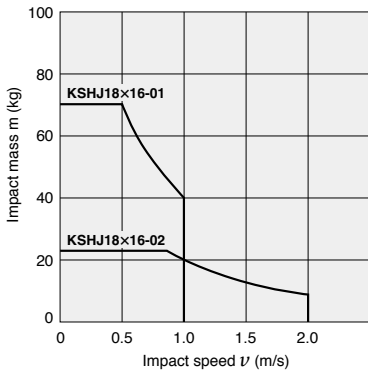

## • KSHJ20×10

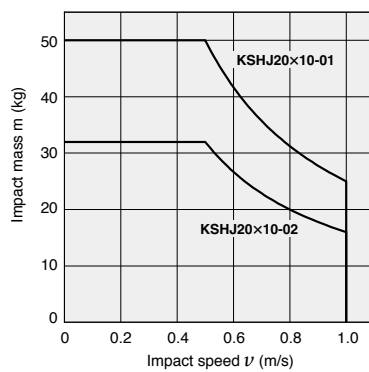

## • KSHJ20×16

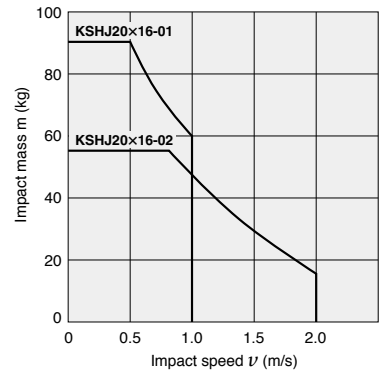

## • KSHJ22×25

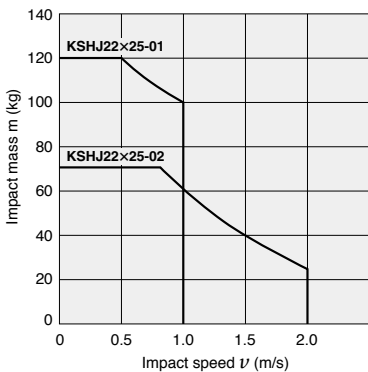

## • KSHJ25×25(-F11)

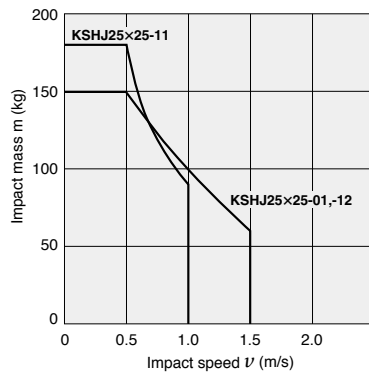

## • KSHJ27×25

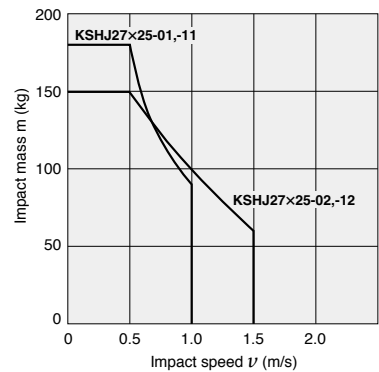



# Selection Guidelines

## • KSHJ30 × 30(-F11)

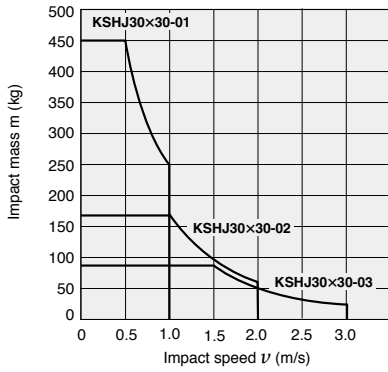

## • KSHJ33 × 30

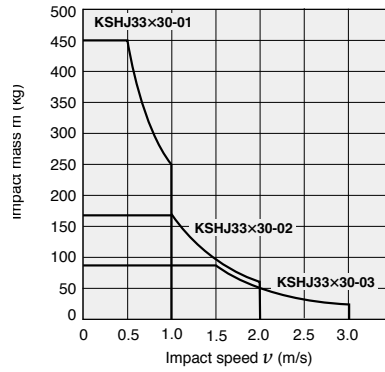

## • KSHJ36 × 50(-F11)

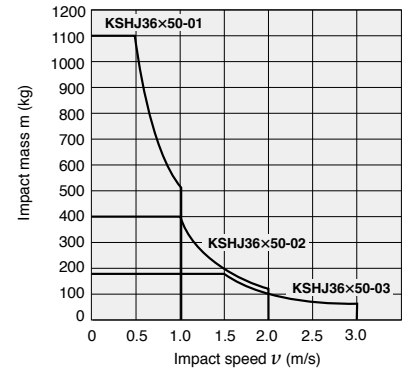

## • KSHJ42 × 50(-F11)

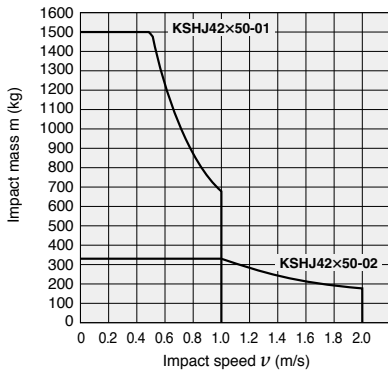

## • KSHJ42 × 70(-F11)

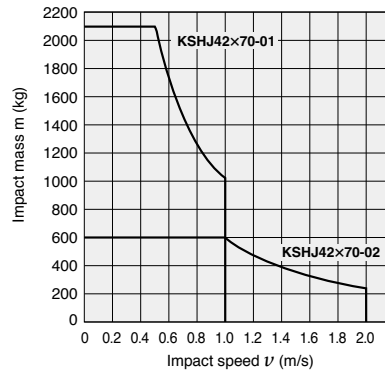

## • KSHJ45 × 50

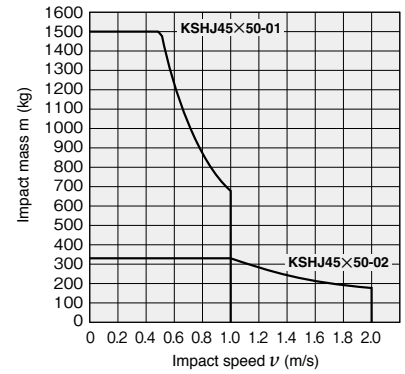

## • KSHJ48 × 50

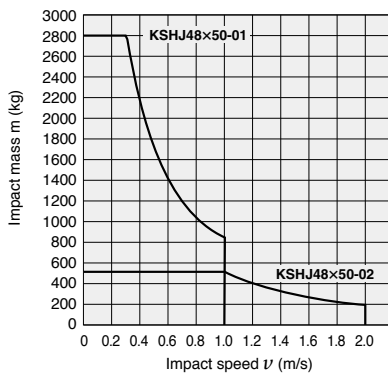

KSHJ

KSHY

KSHP

KSHC

Additional Parts

# Linear orifice shock absorber

## KSHJ Series

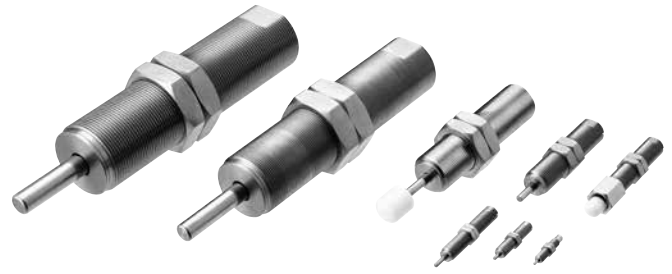

### Specifications

Item	Model (in inches)	KSHJ4		KSHJ6		KSHJ6	
		KSHJ4×3-01 (KSHJ4×3-01-F11)	KSHJ4×3-02 (KSHJ4×3-02-F11)	KSHJ6×4-01 (KSHJ6×4-01-F11)	KSHJ6×4-02 (KSHJ6×4-02-F11)	KSHJ6×6-01 (KSHJ6×6-01-F11)	KSHJ6×6-02 (KSHJ6×6-02-F11)
Maximum absorption capacity	J(in.lbs)	0.3 (2.7)	0.2 (1.8)	0.5 (4.4)	0.3 (2.7)	1 (8.9)	0.5 (4.4)
Absorption stroke	mm(in.)	3 (0.118)		4 (0.157)		6 (0.236)	
Impact speed range	m/s(ft/s)	0.1 to 0.8 (0.33 to 2.62)		0.1 to 1 (0.33 to 3.28)		0.1 to 1 (0.33 to 3.28)	
Maximum operating cycle	cycle/min	90				30	
Maximum absorption capacity per unit of time	J/min (in.lbs/min)	10 (88.6)		20 (177.1)		15 (132.8)	
Spring return force <sup>Note1</sup>	N	2		3		4	
Deflection angle		1° or less					
Operating temperature range <sup>Note2</sup>	°C(°F)	0 to 60 (32 to 140)					

Item	Model (in inches)	KSHJ8		KSHJ8			
		KSHJ8×4-01, -11 (KSHJ8×4-01, -11-F11)	KSHJ8×4-02, -12 (KSHJ8×4-02, -12-F11)	KSHJ8×5-01, -11 (KSHJ8×5-01-F11)	KSHJ8×8-01, -11 (KSHJ8×8-01, -11-F11)	KSHJ8×8-02, -12 (KSHJ8×8-02, -12-F11)	
Maximum absorption capacity	J(in.lbs)	0.75 (6.6)	0.5 (4.4)	1 (8.9)	2 (17.7)		
Absorption stroke	mm(in.)	4 (0.157)		5 (0.197)	8 (0.315)		
Impact speed range	m/s(ft/s)	0.1 to 1 (0.33 to 3.28)		0.1 to 1 (0.33 to 3.28)	0.1 to 1 (0.33 to 3.28)	0.1 to 2 (0.33 to 6.56)	
Maximum operating cycle	cycle/min	60		90			
Maximum absorption capacity per unit of time	J/min (in.lbs/min)	15 (132.8)		36 (318.8)	60 (531.4)		
Spring return force <sup>Note1</sup>	N	6		6	8.6		
Deflection angle		1° or less					
Operating temperature range <sup>Note2</sup>	°C(°F)	0 to 60 (32 to 140)					

Item	Model (in inches)	KSHJ10		KSHJ10		KSHJ10	
		KSHJ10×6-01 (KSHJ10×6-01-F11) (KSHJ11×6-01-F11)	KSHJ10×6-02 (KSHJ10×6-02-F11) (KSHJ11×6-02-F11)	KSHJ10×10-01 (KSHJ10×10-01-F11) (KSHJ11×10-01-F11)	KSHJ10×10-02 (KSHJ10×10-02-F11) (KSHJ11×10-02-F11)	KSHJ10×15-01 (KSHJ10×15-01-F11) (KSHJ11×15-01-F11)	KSHJ10×15-03 (KSHJ10×15-03-F11) (KSHJ11×15-02-F11)
Maximum absorption capacity	J(in.lbs)	1.25 (11.1)	0.75 (6.6)	3 (26.6)		5 (44.3)	6.5 (57.6)
Absorption stroke	mm(in.)	6 (0.236)		10 (0.394)		15 (0.591)	
Impact speed range	m/s(ft/s)	0.1 to 1 (0.33 to 3.28)		0.1 to 1 (0.33 to 3.28)	0.1 to 2 (0.33 to 6.56)	0.1 to 1 (0.33 to 3.28)	0.1 to 3 (0.33 to 9.84)
Maximum operating cycle	cycle/min	60		90			
Maximum absorption capacity per unit of time	J/min (in.lbs/min)	45 (398.5)		120 (1062.7)		200 (1771.2)	
Spring return force <sup>Note1</sup>	N	8		8		9.8	
Deflection angle		1° or less					
Operating temperature range <sup>Note2</sup>	°C(°F)	0 to 60 (32 to 140)					

Item	Model (in inches)	KSHJ12		KSHJ12		KSHJ14	
		KSHJ12×6-01 (KSHJ12×6-01-F11)	KSHJ12×6-02 (KSHJ12×6-02-F11)	KSHJ12×10-01 (KSHJ12×10-01-F11)	KSHJ12×10-02 (KSHJ12×10-02-F11)	KSHJ14×8-01 (KSHJ14×8-01-F11)	KSHJ14×8-02 (KSHJ14×8-02-F11)
Maximum absorption capacity	J(in.lbs)	3 (26.6)	2 (17.7)	6 (53.1)		5 (44.3)	3.25 (28.8)
Absorption stroke	mm(in.)	6 (0.236)		10 (0.394)		8 (0.315)	
Impact speed range	m/s(ft/s)	0.1 to 1 (0.33 to 3.28)		0.1 to 1 (0.33 to 3.28)	0.1 to 2 (0.33 to 6.56)	0.1 to 1 (0.33 to 3.28)	
Maximum operating cycle	cycle/min	60					
Maximum absorption capacity per unit of time	J/min (in.lbs/min)	80 (708.5)		220 (1948.3)		100 (885.6)	
Spring return force <sup>Note1</sup>	N	8		7.6		12.5	
Deflection angle		1° or less					
Operating temperature range <sup>Note2</sup>	°C(°F)	0 to 60 (32 to 140)					

Note1: The spring return force is the force of the piston rod when it returns from a full stroke. It is not stable, so cannot be used as other than rod return.

Note2: The shock absorber's shock absorbing capacity fluctuates based on speed and ambient temperature.

Use the product within the ranges of the selection graphs (impact mass, impact speed diagram) on pages 14 to 16.

Note3: KSHJ11 has only inch specifications.

\* The maximum tightening torque of KSHJ11 is different from that of KSHJ10. See page 11 for details on the maximum tightening torque.

## Specifications

Item	Model (in inches)	KSHJ14×12-01 (KSHJ14×12-01-F11)	KSHJ14×12-02 (KSHJ14×12-02-F11)	KSHJ16×8-01	KSHJ16×8-02	KSHJ16×15-01	KSHJ16×15-02
Maximum absorption capacity	J(in.lbs)	10 (88.6)		7.5	5	15	
Absorption stroke	mm(in.)	12 (0.472)		8		15	
Impact speed range	m/s(ft/s)	0.1 to 1 (0.33 to 3.28)	0.1 to 2 (0.33 to 6.56)	0.1 to 1		0.1 to 1	0.1 to 2
Maximum operating cycle	cycle/min	60		40			
Maximum absorption capacity per unit of time	J/min (in.lbs/min)	240 (2125.4)		130		280	
Spring return force <sup>Note1</sup>	N	9.2		12.5		17.4	
Deflection angle		1° or less		3° or less			
Operating temperature range <sup>Note2</sup>	°C(°F)	0 to 60 (32 to 140)					

Item	Model (in inches)	KSHJ18×16-01 (KSHJ18×16-01-F11)	KSHJ18×16-02 (KSHJ18×16-02-F11)	KSHJ20×10-01	KSHJ20×10-02	KSHJ20×16-01	KSHJ20×16-02
Maximum absorption capacity	J(in.lbs)	20 (177.0)		12.5	8	30	
Absorption stroke	mm(in.)	16 (0.630)		10		16	
Impact speed range	m/s(ft/s)	0.1 to 1 (0.33 to 3.28)	0.1 to 2 (0.33 to 6.56)	0.1 to 1		0.1 to 1	0.1 to 2
Maximum operating cycle	cycle/min	40				30	
Maximum absorption capacity per unit of time	J/min (in.lbs/min)	320 (2833.9)		200		450	
Spring return force <sup>Note1</sup>	N	22		15		22	
Deflection angle		3° or less					
Operating temperature range <sup>Note2</sup>	°C(°F)	0 to 60 (32 to 140)					

Item	Model (in inches)	KSHJ22×25-01	KSHJ22×25-02	KSHJ25×25-01	KSHJ25×25-11 (KSHJ25×25-01-F11)	KSHJ25×25-12 (KSHJ25×25-02-F11)
Maximum absorption capacity	J(in.lbs)	50		60 (531.0)		
Absorption stroke	mm(in.)	25		25 (0.984)		
Impact speed range	m/s(ft/s)	0.1 to 1	0.1 to 1	0.1 to 1.5	0.1 to 1 (0.33 to 3.28)	0.1 to 1.5 (0.33 to 4.92)
Maximum operating cycle	cycle/min	30				
Maximum absorption capacity per unit of time	J/min (in.lbs/min)	500		700	800 (7084.8)	
Spring return force <sup>Note1</sup>	N	28.5				
Deflection angle		3° or less				
Operating temperature range <sup>Note2</sup>	°C(°F)	0 to 60 (32 to 140)				

Item	Model (in inches)	KSHJ27×25-01,-11	KSHJ27×25-02,-12	KSHJ30×30-01 (KSHJ30×30-01-F11)	KSHJ30×30-02 (KSHJ30×30-02-F11)	KSHJ30×30-03 (KSHJ30×30-03-F11)
Maximum absorption capacity	J(in.lbs)	60		140 (1239.1)		
Absorption stroke	mm(in.)	25		30 (1.181)		
Impact speed range	m/s(ft/s)	0.1 to 1	0.1 to 1.5	0.1 to 1 (0.33 to 3.28)	0.1 to 2 (0.33 to 6.56)	0.1 to 3 (0.33 to 9.84)
Maximum operating cycle	cycle/min	30		20		
Maximum absorption capacity per unit of time	J/min (in.lbs/min)	800		900 (7970.4)		
Spring return force <sup>Note1</sup>	N	28.5		41.5		
Deflection angle		3° or less				
Operating temperature range <sup>Note2</sup>	°C(°F)	0 to 60 (32 to 140)				

Note1: The spring return force is the force of the piston rod when it returns from a full stroke. It is not stable, so cannot be used as other than rod return.

Note2: The shock absorber's shock absorbing capacity fluctuates based on speed and ambient temperature.

Use the product within the ranges of the selection graphs (impact mass, impact speed diagram) on pages 14 to 16.

Note3: KSHJ16×8, KSHJ16×15, KSHJ20×10, KSHJ20×16, KSHJ22×25, KSHJ27×25, KSHJ33×30, KSHJ45×50, and KSHJ48×50 do not have inch specifications.

## Specifications

Item	Model (in inches)	KSHJ33 × 30-01	KSHJ33 × 30-02	KSHJ33 × 30-03	KSHJ36 × 50-01 (KSHJ36×50-01-F11)	KSHJ36 × 50-02 (KSHJ36×50-02-F11)	KSHJ36 × 50-03 (KSHJ36×50-03-F11)
Maximum absorption capacity	J(in.lbs)	140			300 (2655.2)		
Absorption stroke	mm(in.)	30			50 (1.969)		
Impact speed range	m/s(ft/s)	0.1 to 1	0.1 to 2	0.1 to 3	0.1 to 1 (0.33 to 3.28)	0.1 to 2 (0.33 to 6.56)	0.1 to 3 (0.33 to 9.84)
Maximum operating cycle	cycle/min	20			20		
Maximum absorption capacity per unit of time	J/min (in.lbs/min)	900			1800 (15940.8)		
Spring return force <sup>Note1</sup>	N	41.5			66.5		
Deflection angle		3° or less					
Operating temperature range <sup>Note2</sup>	°C(°F)	0 to 60 (32 to 140)					

Item	Model (in inches)	KSHJ42 × 50-01 (KSHJ42 × 50-01-F11)	KSHJ42 × 50-02 (KSHJ42 × 50-02-F11)	KSHJ42 × 70-01 (KSHJ42 × 70-01-F11)	KSHJ42 × 70-02 (KSHJ42 × 70-02-F11)
Maximum absorption capacity	J(in.lbs)	400 (3540.3)		600 (5310.4)	
Absorption stroke	mm(in.)	50 (1.969)		70 (2.756)	
Impact speed range	m/s(ft/s)	0.1 to 1 (0.33 to 3.28)	0.1 to 2 (0.33 to 6.56)	0.1 to 1 (0.33 to 3.28)	0.1 to 2 (0.33 to 6.56)
Maximum operating cycle	cycle/min	15		15	
Maximum absorption capacity per unit of time	J/min (in.lbs/min)	2400 (21254.4)		2400 (21254.4)	
Spring return force <sup>Note1</sup>	N	85.0		68.0	
Deflection angle		3° or less		1° or less	
Operating temperature range <sup>Note2</sup>	°C(°F)	0 to 60 (32 to 140)			

Item	Model (in inches)	KSHJ45 × 50-01	KSHJ45 × 50-02	KSHJ48 × 50-01	KSHJ48 × 50-02
Maximum absorption capacity	J(in.lbs)	400		500	
Absorption stroke	mm(in.)	50		50	
Impact speed range	m/s(ft/s)	0.1 to 1	0.1 to 2	0.1 to 1	0.1 to 2
Maximum operating cycle	cycle/min	15		15	
Maximum absorption capacity per unit of time	J/min (in.lbs/min)	2400		3000	
Spring return force <sup>Note1</sup>	N	85.0		86.0	
Deflection angle		3° or less			
Operating temperature range <sup>Note2</sup>	°C(°F)	0 to 60			

Note1: The spring return force is the force of the piston rod when it returns from a full stroke. It is not stable, so cannot be used as other than rod return.

Note2: The shock absorber's shock absorbing capacity fluctuates based on speed and ambient temperature.

Use the product within the ranges of the selection graphs (impact mass, impact speed diagram) on pages 14 to 16.

Note3: KSHJ16 × 8, KSHJ16 × 15, KSHJ20 × 10, KSHJ20 × 16, KSHJ22 × 25, KSHJ27 × 25, KSHJ33 × 30, KSHJ45 × 50, KSHJ48 × 50 do not have inch specifications.

## Mass

### Specifications in mm

g

Model	Main unit <sup>Note</sup>	Additional mass	Additional parts' mass		
		With plastic cap	Mounting nut (1 ea.)	Stopper nut	Side mounting bracket
KSHJ4 × 3-01, -02	1.8	0.1	0.2	1	7
KSHJ6 × 4-01, -02	4	0.2	0.4	2	8
KSHJ6 × 6-01, -02	5	0.2	0.4	2	8
KSHJ8 × 4-01, -02, -11, -12 (with hexagon socket)	10	0.5	0.6(0.9)	4	12
KSHJ8 × 5-01, -11	10	0.5	0.6(0.9)	4	12
KSHJ8 × 8-01, -02, -11, -12	11.5	0.5	0.6(0.9)	4	12
KSHJ10 × 6-01, -02 (with hexagon socket)	21	0.6	1.2	7	15
KSHJ10 × 10-01, -02	22	0.6	1.2	7	15
KSHJ10 × 15-01, -03	28	0.6	1.2	7	15
KSHJ12 × 6-01, 02 (with hexagon socket)	31	1.2	1.9	8	22
KSHJ12 × 10-01, -02	37	1.2	1.9	8	22
KSHJ14 × 8-01, 02 (with hexagon socket)	55	1.4	4	15	41
KSHJ14 × 12-01, -02	58	1.4	4	15	41
KSHJ16 × 8-01, -02 (with hexagon socket)	73	1.4	6.6	28	65
KSHJ16 × 15-01, -02	83	1.4	6.6	28	65
KSHJ18 × 16-01, -02	113	3.0	8.8	37	100
KSHJ20 × 10-01, -02 (with hexagon socket)	131	3.0	12.2	55	110
KSHJ20 × 16-01, -02	156	3.0	12.2	55	110
KSHJ22 × 25-01, -02	233	7.0	18.2	82	390
KSHJ25 × 25-01	307	7.0	23	95	360
KSHJ25 × 25-11, -12	300	7.0	24.5	95	360
KSHJ27 × 25-01, -02	415	7.0	42	180	460
KSHJ27 × 25-11, -12	395	7.0	54	180	460
KSHJ30 × 30-01, -02, -03	520	50	32.5	140	455
KSHJ33 × 30-01, -02, -03	675	50	47.5	390	2800
KSHJ36 × 50-01, -02, -03	1070	110	95.5	330	2650
KSHJ42 × 50-01, -02	1310	110	93	320	2400
KSHJ42 × 70-01, -02	1500	110	93	320	2400
KSHJ45 × 50-01, -02	1610	110	123	420	3400
KSHJ48 × 50-01, -02	1830	210	100	400	3400

Calculation example: The mass of KSHJ10×10C-01-S-2 (with cap, stopper, and side mount) is  
 $22 + 0.6 + 7 + 15 = 44.6g$

Note: The weight of the main unit includes the weight of 2 mounting nuts.

### Specifications in inches

oz

Model	Main unit <sup>Note1</sup>	Additional mass	Additional parts' mass	
		With plastic cap	Mounting nut (1 ea.)	Stopper nut
KSHJ4 × 3-01, -02 -F11	0.1	0.004	0.01	0.04
KSHJ6 × 4-01, -02 -F11	0.2	0.007	0.04	0.1
KSHJ6 × 6-01, -02 -F11	0.2	0.007	0.04	0.1
KSHJ8 × 4-01, -02, -11, -12 -F11	0.4	0.02	0.06	0.2
KSHJ8 × 5-01 -F11	0.4	0.02	0.06	0.2
KSHJ8 × 8-01, -02, -11, -12 -F11	0.5	0.02	0.06	0.2
KSHJ10 × 6-01, -02 -F11	0.7	0.02	0.07	0.4
KSHJ10 × 10-01, -02 -F11	0.8	0.02	0.07	0.4
KSHJ10 × 15-01, -03 -F11	1.0	0.02	0.07	0.4
KSHJ11 × 6-01, -02 -F11 <sup>Note2</sup>	1.0	0.02	0.09	0.4
KSHJ11 × 10-01, -02 -F11 <sup>Note2</sup>	1.2	0.02	0.09	0.4
KSHJ11 × 15-01, -03 -F11 <sup>Note2</sup>	1.4	0.02	0.09	0.4
KSHJ12 × 6-01, 02 -F11	1.3	0.04	0.1	0.5
KSHJ12 × 10-01, -02 -F11	1.5	0.04	0.1	0.5
KSHJ14 × 8-01, 02 -F11	2.2	0.05	0.2	0.7
KSHJ14 × 12-01, -02 -F11	2.2	0.05	0.2	0.7
KSHJ18 × 16-01, -02 -F11	4.8	0.1	0.4	2.5
KSHJ25 × 25-11, -12 -F11	11.3	0.2	1.2	4.4
KSHJ30 × 30-01, -02, -03 -F11	20.6	1.8	1.3	5.5
KSHJ36 × 50-01, -02, -03 -F11	33.9	3.9	3.0	9.8
KSHJ42 × 50-01, -02 -F11	51.5	3.9	3.4	10.8
KSHJ42 × 70-01, -02 -F11	59.6	3.9	3.4	10.8

Calculation example: The mass of KSHJ10×10C-01-S-2 (with cap and stopper) is  
 $0.8 + 0.02 + 0.4 = 1.58oz$

Note1: The weight of the main unit includes the weight of 2 mounting nuts.

Note2: KSHJ11 has only inch specifications.

## Order Codes (specifications in mm)

### • 4×3

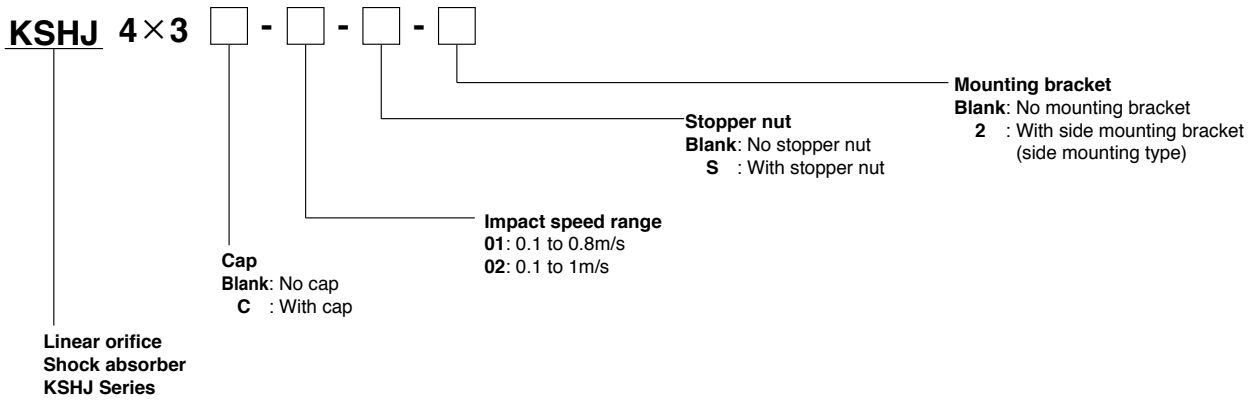

### • 6×4

### 6×6

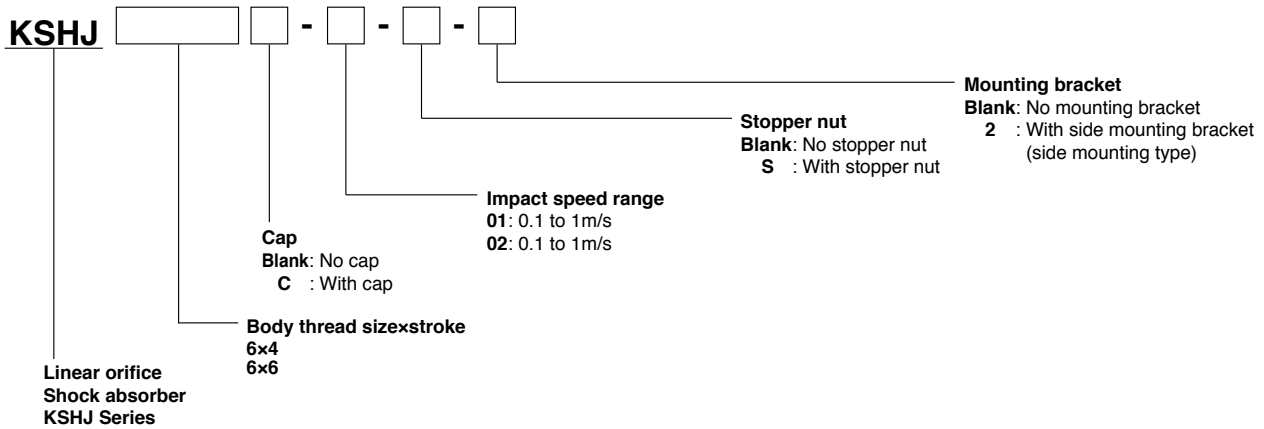

### • 8×5

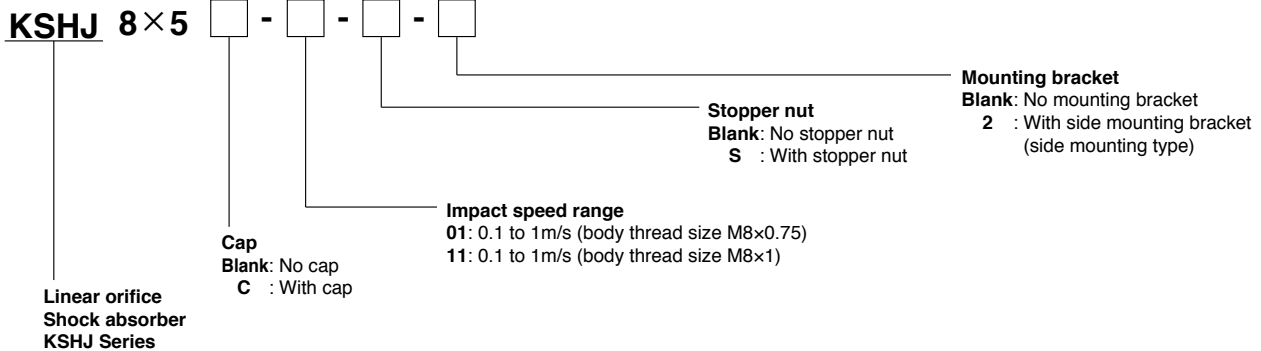

### • 8×8

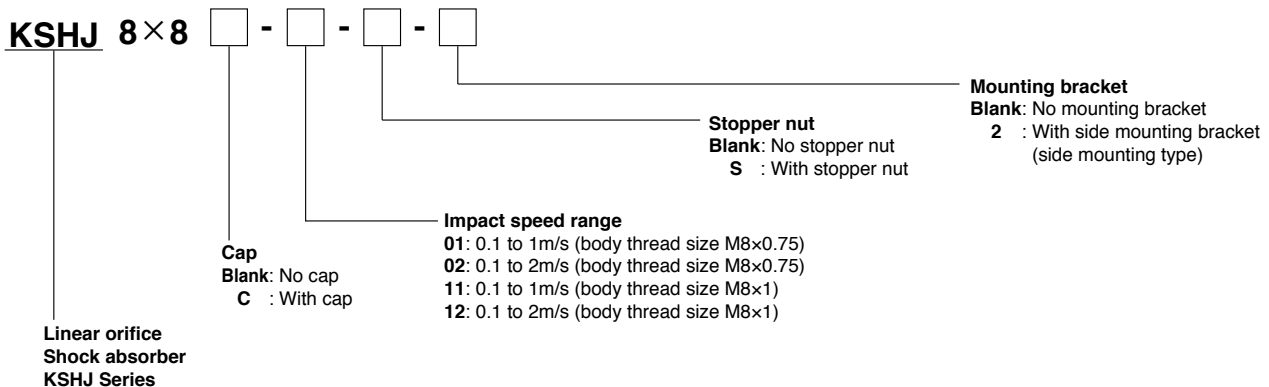

# Order Codes (specifications in mm)

## • 10×15

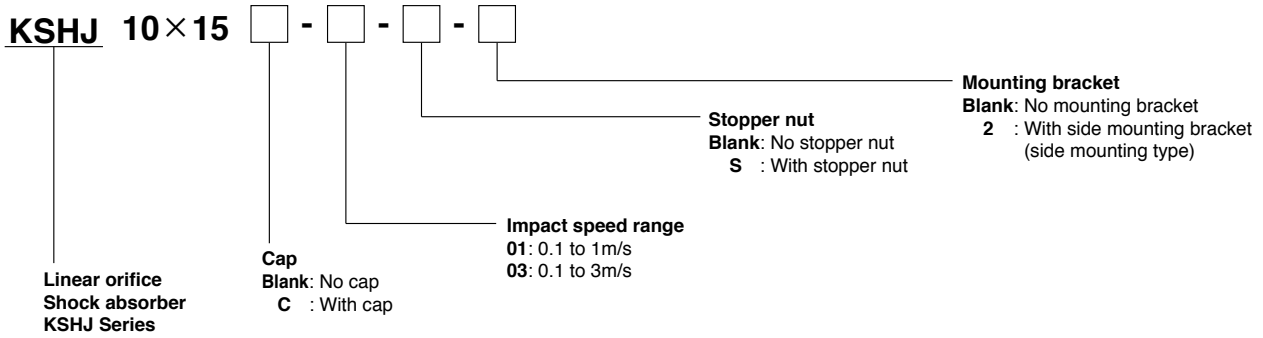

## • 10×10 12×10 14×12 16×15 18×16 20×16 22×25

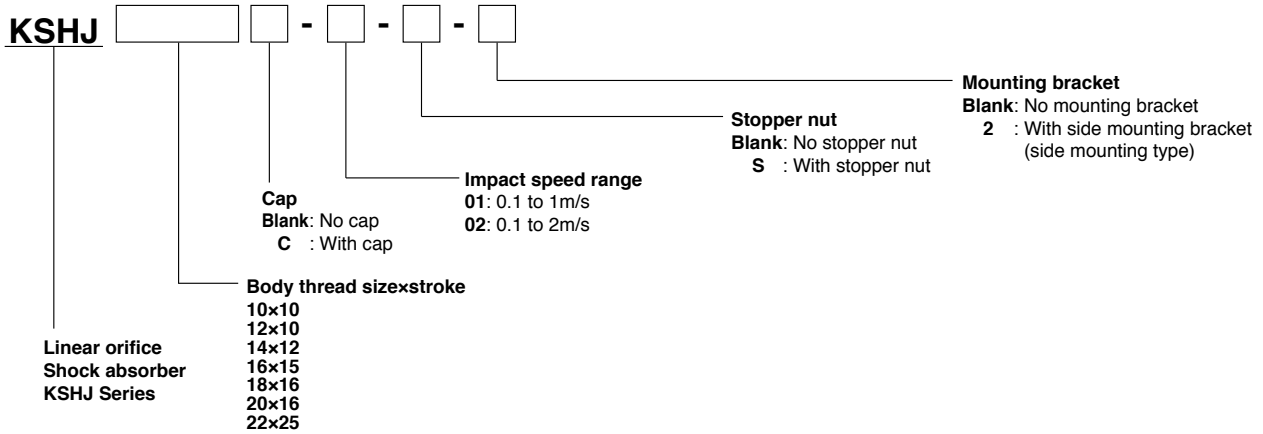

## • 25×25

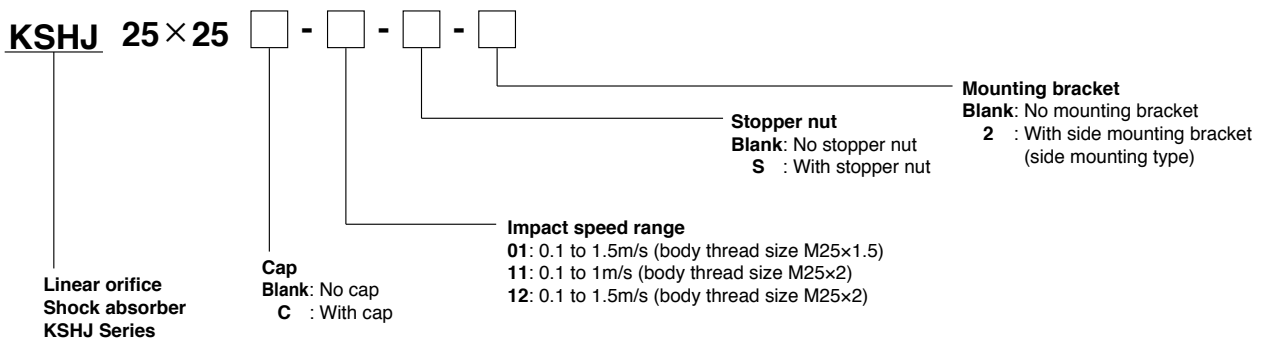

## • 27×25

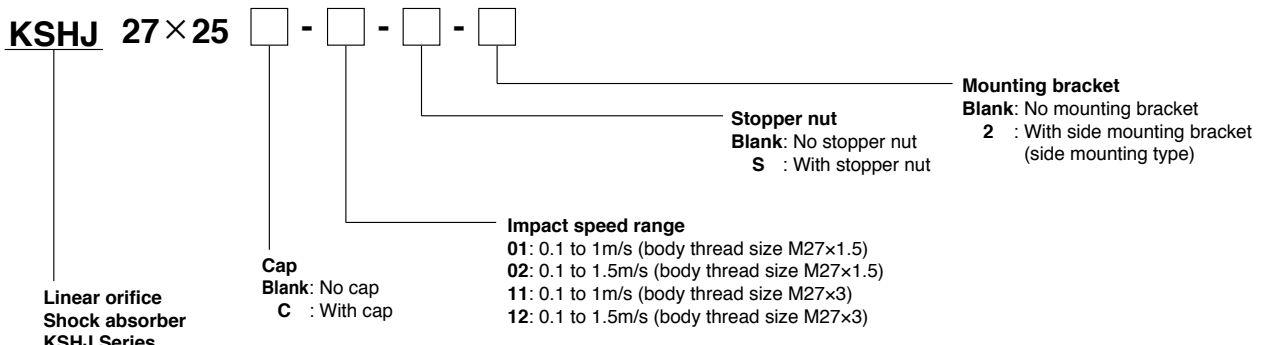

KSHJ

KSHY

KSHP

KSCH

Additional Parts

## Order Codes (specifications in mm)

- 30 × 30
- 33 × 30
- 36 × 50

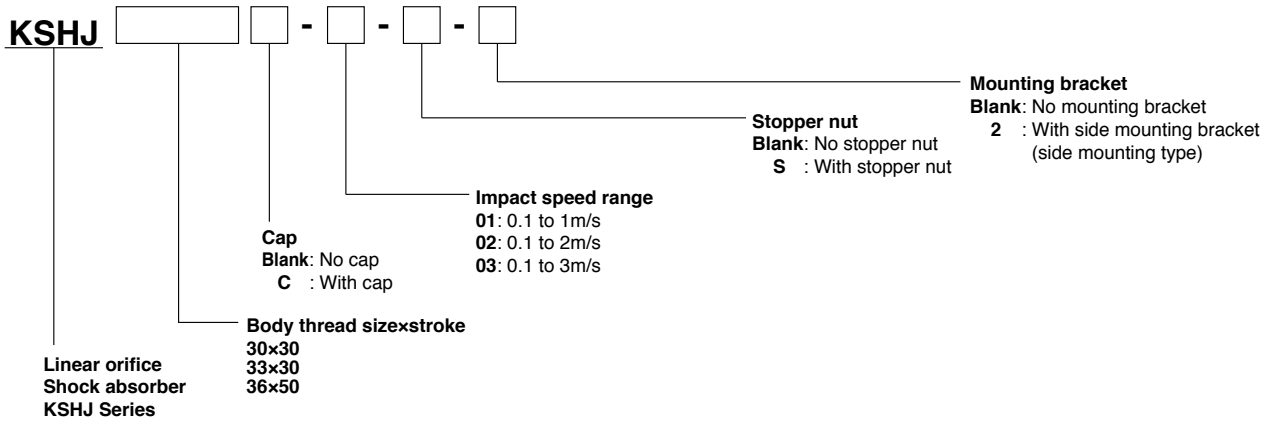

- 42 × 50
- 42 × 70
- 45 × 50
- 48 × 50

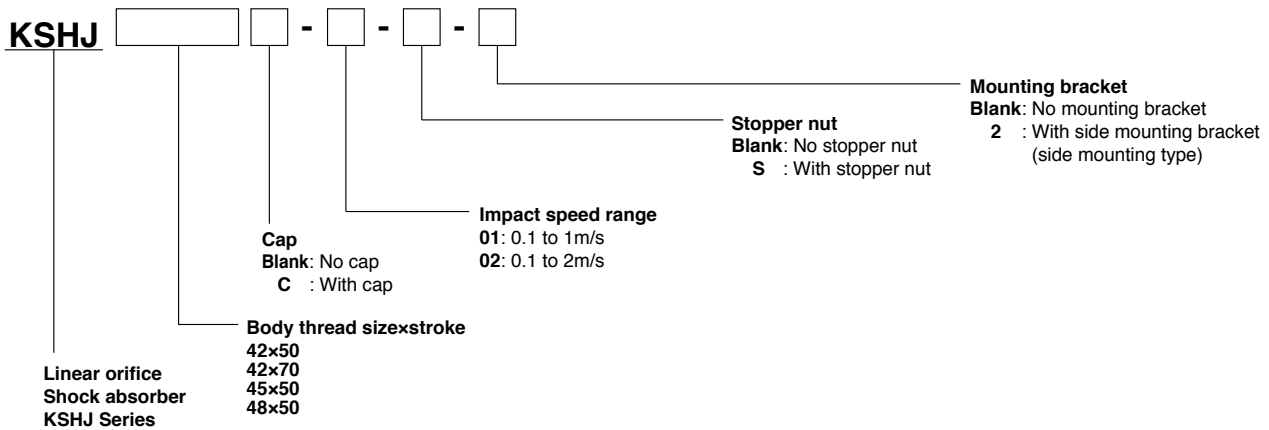

### Short stroke type (with hexagon socket)

- 8 × 4
- 10 × 6
- 12 × 6
- 14 × 8
- 16 × 8
- 20 × 10

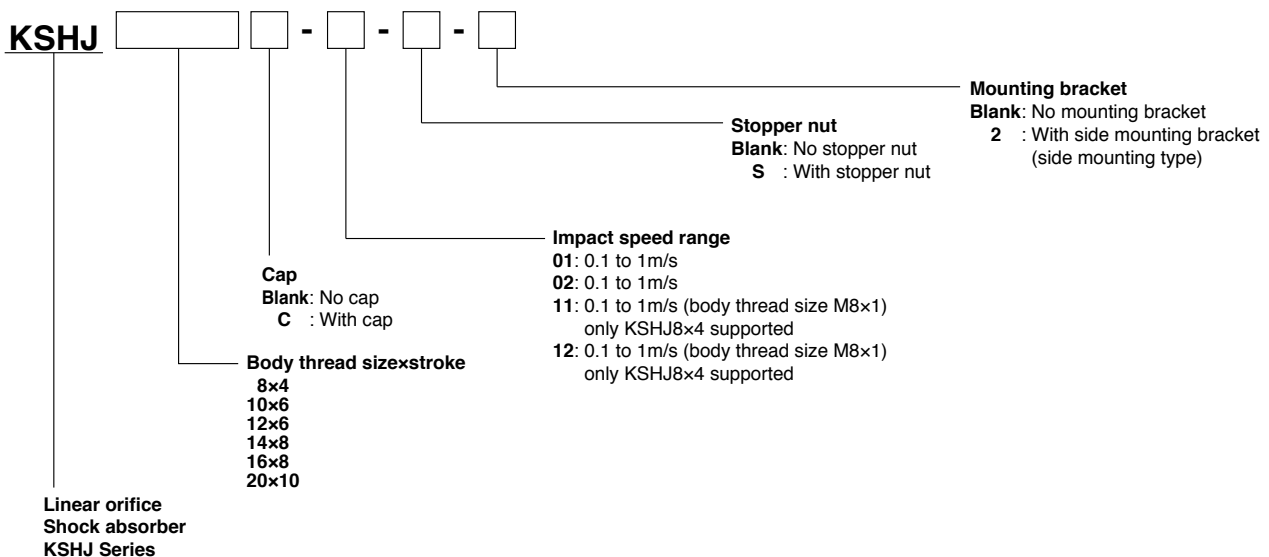



## Order Codes (specifications in mm)

### Additional Parts (no specifications in inches)

● **Mounting nut** (M4 to M20: 1 pack has 10 units)<sup>Note</sup>  
(M22 to M48: 1 pack has 2 units)

**N - KSH - M**



- Thread size**
- 4: For KSHJ4
  - 6: For KSHJ6
  - 8: For KSHJ8(-01,02)
  - 8-11: For KSHJ8(-11,12)
  - 10: For KSHJ10
  - 12: For KSHJ12
  - 14: For KSHJ14
  - 16: For KSHJ16
  - 18: For KSHJ18
  - 20: For KSHJ20
  - 22: For KSHJ22
  - 25: For KSHJ25-01
  - 25-11: For KSHJ25(-11,12)
  - 27: For KSHJ27(-01,02)
  - 27-11: For KSHJ27(-11,12)
  - 30: For KSHJ30
  - 33: For KSHJ33
  - 36: For KSHJ36
  - 42: For KSHJ42
  - 45: For KSHJ45
  - 48: For KSHJ48

● **Stopper nut**

**S - KSH - M**

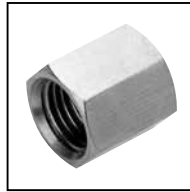

- Thread size**
- 4: For KSHJ4
  - 6: For KSHJ6
  - 8: For KSHJ8(-01,02)
  - 8-11: For KSHJ8(-11,12)
  - 10: For KSHJ10
  - 12: For KSHJ12
  - 14: For KSHJ14
  - 16: For KSHJ16
  - 18: For KSHJ18
  - 20: For KSHJ20
  - 22: For KSHJ22
  - 25: For KSHJ25-01
  - 25-11: For KSHJ25(-11,12)
  - 27: For KSHJ27(-01,02)
  - 27-11: For KSHJ27(-11,12)
  - 30: For KSHJ30
  - 33: For KSHJ33
  - 36: For KSHJ36
  - 42: For KSHJ42
  - 45: For KSHJ45
  - 48: For KSHJ48

● **Side mounting bracket**

**2 - KSH - M**



- Thread size**
- 4: For KSHJ4
  - 6: For KSHJ6
  - 8: For KSHJ8(-01,02)
  - 8-11: For KSHJ8(-11,12)
  - 10: For KSHJ10
  - 12: For KSHJ12
  - 14: For KSHJ14
  - 16: For KSHJ16
  - 18: For KSHJ18
  - 20: For KSHJ20
  - 22: For KSHJ22
  - 25: For KSHJ25-01
  - 25-11: For KSHJ25(-11,12)
  - 27: For KSHJ27(-01,02)
  - 27-11: For KSHJ27(-11,12)
  - 30: For KSHJ30
  - 33: For KSHJ33
  - 36: For KSHJ36
  - 42: For KSHJ42
  - 45: For KSHJ45
  - 48: For KSHJ48

Note: The mounting nut for thread size M45 is nominal number AN09 prescribed in JIS B1554 (nuts for rolling bearings).

\* For the dimension diagrams of the additional parts, see pages 72 to 76.

\* The stopper nut and side mount are made from mild steel (nickel plated).

## Inner Construction and Major Parts and Materials

● M4 to M27 size (10-32UNF to 1-12UNF) \* The inch sizes are inside the ( ).

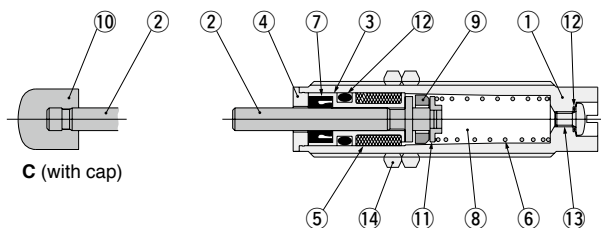

Note: Some parts and interior shapes may vary depending on size.

No.	Name	Materials
①	Body <sup>Note1</sup>	Copper alloy (nickel plated)
②	Piston rod <sup>Note2</sup>	Steel (nickel plated)
③	Sleeve	Copper alloy
④	Plug	Stainless steel
⑤	Accumulator	Synthetic rubber
⑥	Spring	Spring steel
⑦	Rod seal	Synthetic rubber
⑧	Oil	Special oil
⑨	Piston ring	Copper alloy
⑩	Cap	Plastic (POM)
⑪	Collar <sup>Note3</sup>	Stainless steel, copper alloy
⑫	O-ring	Synthetic rubber
⑬	Screw <sup>Note4</sup>	Mild steel (zinc plated)
⑭	Mounting nut	Mild steel (nickel plated)

Note1: KSHJ4, 6, and 8×4 are stainless steel

2: KSHJ8, 10×10, and 12×10 are stainless steel

3: KSHJ6 and 8 are copper alloy

KSHJ10 and 12, and 14×12 are sintered metal

4: KSHJ4, 6, and 8 are nickel plated

● M30 to M48 size (1 1/4-12UNF to 1 3/4-12UN) \* The inch sizes are inside the ( ).

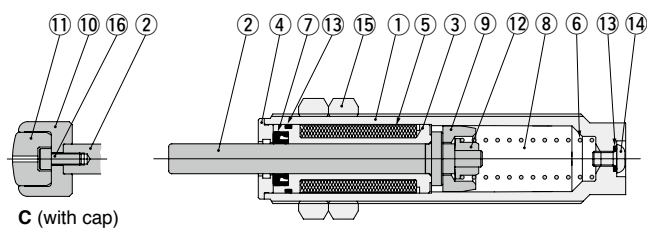

Note: Some parts and interior shapes may vary depending on size.

No.	Name	Materials
①	Body	Free-cutting steel (nickel plated)
②	Piston rod	Steel (nickel plated)
③	Sleeve	Copper alloy
④	Plug	Stainless steel
⑤	Accumulator	Synthetic rubber
⑥	Spring	Spring steel
⑦	Rod seal	Synthetic rubber
⑧	Oil	Special oil
⑨	Piston ring <sup>Note</sup>	Copper alloy
⑩	Metal cap	Stainless steel
⑪	Cap	Plastic (POM)
⑫	Collar	Stainless steel
⑬	O-ring	Synthetic rubber
⑭	Button head screw	Stainless steel
⑮	Mounting nut	Mild steel (nickel plated)
⑯	Hexagon socket head screw	Mild steel (nickel plated)

Note: KSHJ42, 45, and 48 are stainless steel

## Dimensions (mm)

●No rod end cap: KSHJ4×3, KSHJ6×4, KSHJ6×6

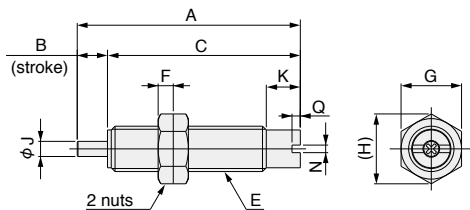

●With rod end cap: KSHJ4×3C, KSHJ6×4C, KSHJ6×6C

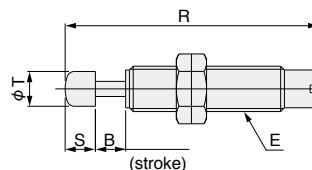

Model	Symbol	A	B	C	E	F	G	H	J	K	N	Q	R	S	T
KSHJ4×3 (C)-01,-02		25	3	22	M4×0.5	2	5.5	6.4	1.2	3	1	1.1	28.5	3.5	3.2
KSHJ6×4 (C)-01,-02		29.5	4	25.5	M6×0.75	2	8	9.2	2	4.5	1	1	33.5	4	4.6
KSHJ6×6 (C)-01,-02		35.5	6	29.5	M6×0.75	2	8	9.2	2	5.5	1	1	39.5	4	4.6

●No rod end cap: KSHJ□×□-□

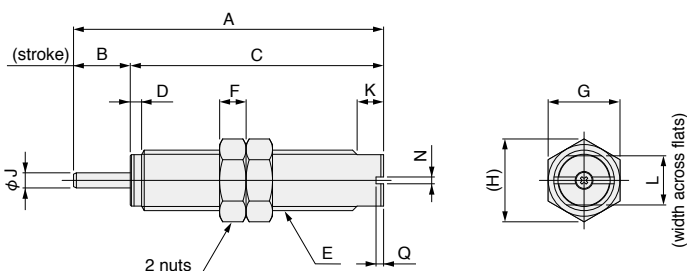

●With rod end cap: KSHJ□×□C-□

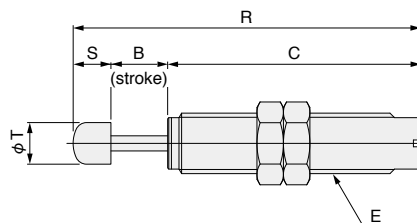

Model	Symbol	A	B	C	D	E	F	G	H	J	K	L	N	Q	R	S	T
KSHJ8×5 (C)-01		37	5	32	1.2	M8×0.75	2	10	11.5	2.5	3	7	1.3	1.5	42	5	6.5
KSHJ8×5 (C)-11		37	5	32	1.2	M8×1	3	10	11.5	2.5	3	7	1.3	1.5	42	5	6.5
KSHJ8×8 (C)-01,-02		46	8	38	1.2	M8×0.75	2	10	11.5	2.5	3	7	1.3	1.5	51	5	6.5
KSHJ8×8 (C)-11,-12		46	8	38	1.2	M8×1	3	10	11.5	2.5	3	7	1.3	1.5	51	5	6.5
KSHJ10×10 (C)-01,-02		60	10	50	2	M10×1	3	12	13.9	3	5	8.5	1.3	1.5	68	8	8
KSHJ10×15 (C)-01,-03		77	15	62	2.3	M10×1	3	12	13.9	3	5	8.5	1.3	1.5	85	8	8
KSHJ12×10 (C)-01,-02		66	10	56	2	M12×1	4	14	16.2	3	5	10.5	1.3	1.5	76	10	10
KSHJ14×12 (C)-01,-02		72	12	60	2	M14×1.5	5	17	19.6	4	5	12	1.3	1.5	82	10	11
KSHJ16×15 (C)-01,-02		82	15	67	3	M16×1.5	7	19	21.9	4	7	13	1.8	2	92	10	11
KSHJ18×16 (C)-01,-02		88	16	72	3	M18×1.5	8	21	24.2	5	7	15	1.8	2	103	15	15
KSHJ20×16 (C)-01,-02		93	16	77	3	M20×1.5	8	24	27.7	5	7	17	1.8	2	108	15	15
KSHJ22×25 (C)-01,-02		125	25	100	3	M22×1.5	9	27	31.2	6	10	19	1.8	2	143	18	18
KSHJ25×25 (C)-01		125	25	100	3	M25×1.5	10	30	34.6	6	10	22	1.8	2	143	18	18
KSHJ25×25 (C)-11,-12		125	25	100	3	M25×2	10	30	34.6	6	10	22	1.8	2	143	18	18

●No rod end cap: KSHJ27×25-□

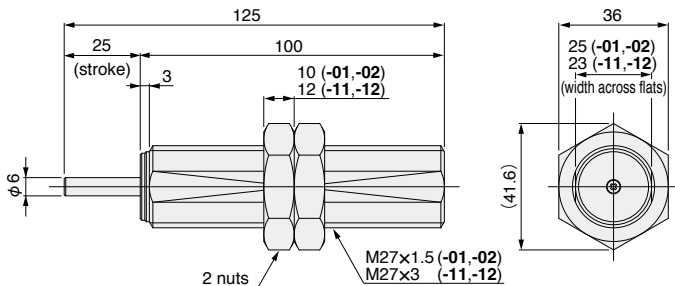

●With rod end cap: KSHJ27×25C-□

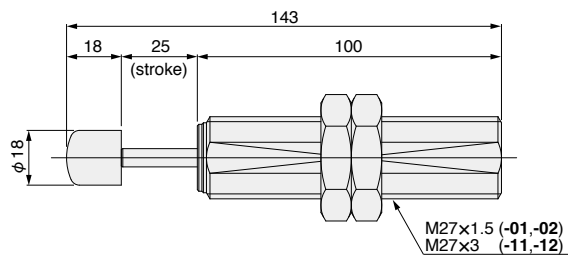

## Dimensions (mm)

●No rod end cap: KSHJ□×□-□

●With rod end cap: KSHJ□×□C-□

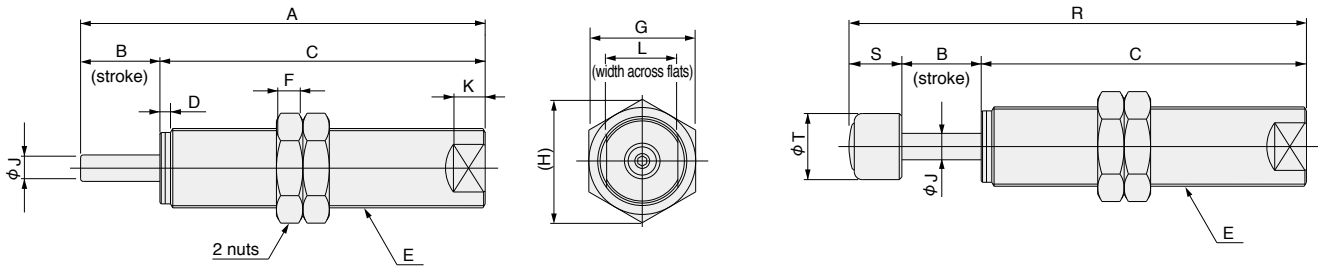

Model	Symbol	A	B	C	D	E	F	G	H	J	K	L	R	S	T
KSHJ30×30 (C)-01,-02,-03		153	30	123	4	M30×1.5	10	36	41.6	10	12	24	173	20	25
KSHJ33×30 (C)-01,-02,-03		153	30	123	4	M33×1.5	10	41	47.3	10	12	27	173	20	25
KSHJ36×50 (C)-01,-02,-03		218	50	168	5	M36×1.5	15	46	53.1	12	15	30	243	25	32
KSHJ42×50 (C)-01,-02		220	50	170	5	M42×1.5	15	50	57.7	12	20	36	245	25	32
KSHJ42×70 (C)-01,-02		275	70	205	5	M42×1.5	15	50	57.7	12	20	36	300	25	32
KSHJ48×50 (C)-01,-02		230	50	180	6	M48×2	15	55	63.5	14	20	40	263	33	38

●No rod end cap: KSHJ45×50-01, -02

●With rod end cap: KSHJ45×50C-01, -02

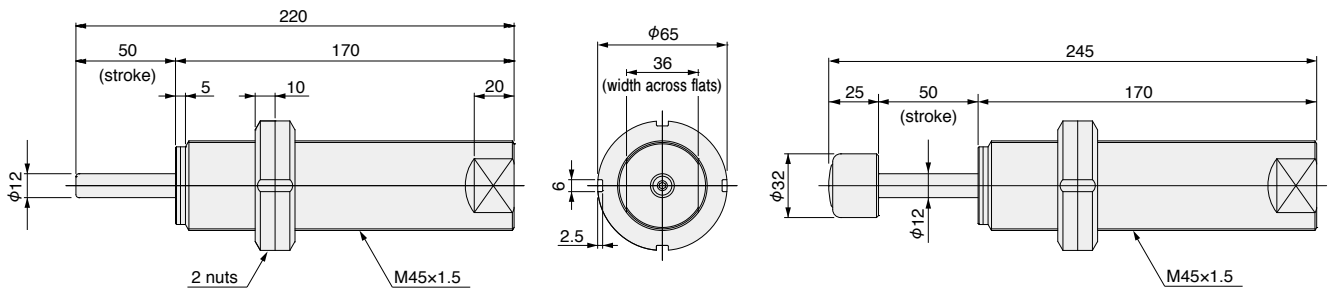

## Short stroke type (with hexagon socket)

●No rod end cap: KSHJ□×□-□

●With rod end cap: KSHJ□×□C-□

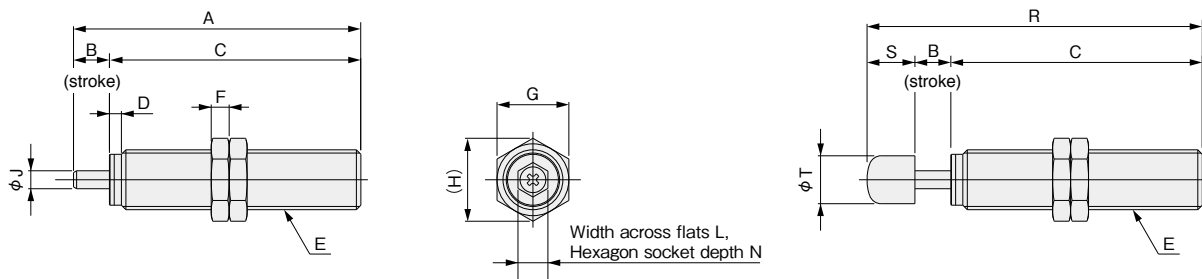

Model	Symbol	A	B	C	D	E	F	G	H	J	L	N	R	S	T
KSHJ8×4 (C)-01,-02		37	4	33	2.2	M8×0.75	2	10	11.5	2.5	4	2	42	5	6.5
KSHJ8×4 (C)-11,-12		37	4	33	2.2	M8×1.0	3	10	11.5	2.5	4	2	42	5	6.5
KSHJ10×6 (C)-01,-02		48	6	42	2	M10×1	3	12	13.9	3	5	3	56	8	8
KSHJ12×6 (C)-01,-02		48	6	42	2	M12×1	4	14	16.2	3	6	3	58	10	10
KSHJ14×8 (C)-01,-02		61	8	53	2	M14×1.5	5	17	19.6	4	6	3	71	10	11
KSHJ16×8 (C)-01,-02		61	8	53	3	M16×1.5	7	19	21.9	4	6	4	71	10	11
KSHJ20×10 (C)-01,-02		69	10	59	3	M20×1.5	8	24	27.7	5	6	4	84	15	15

## Order Codes (specifications in inches)

### • 4×3

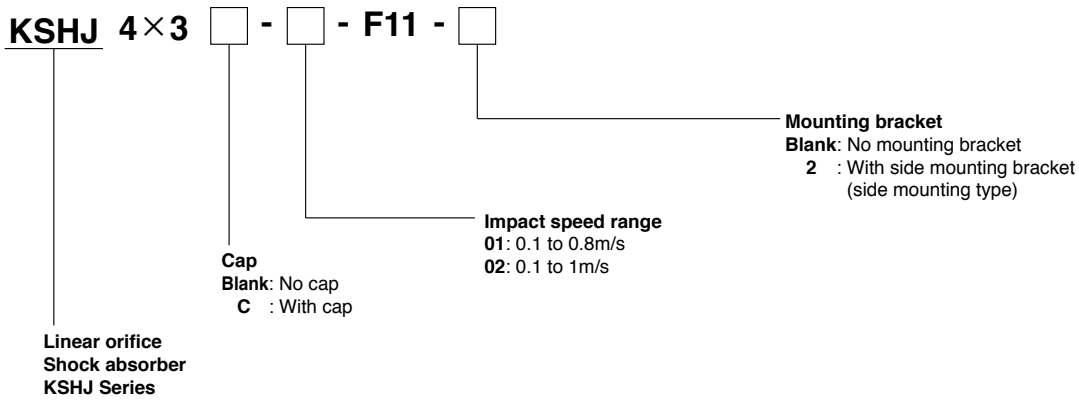

### • 6×4

### 6×6

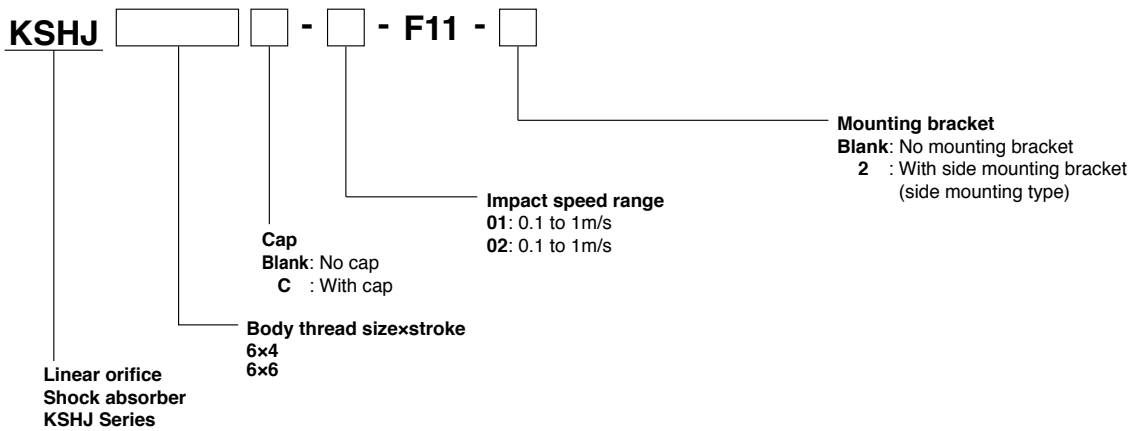

### • 8×5

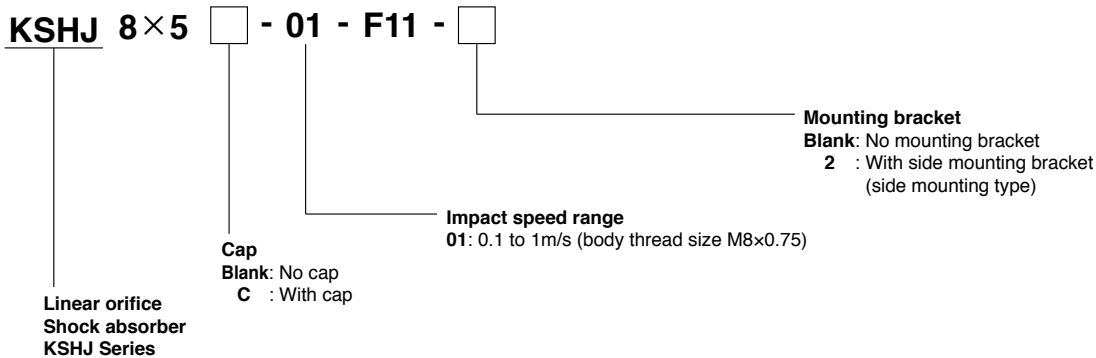

### • 8×8

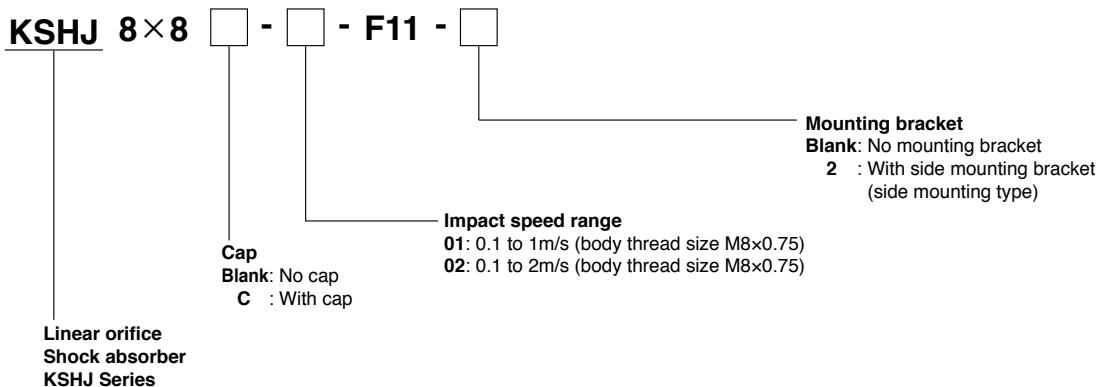

KSHJ

KSHY

KSHP

KSHC

Additional Parts

## Order Codes (specifications in inches)

### • 10×15

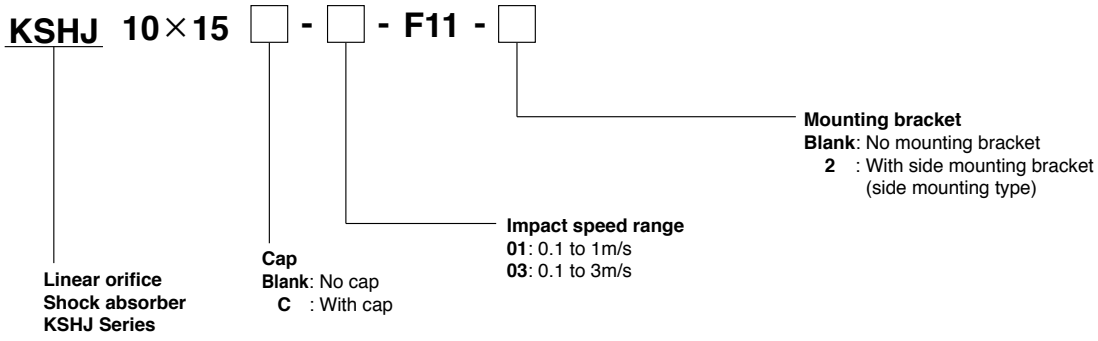

### • 10×10 12×10 14×12 18×16

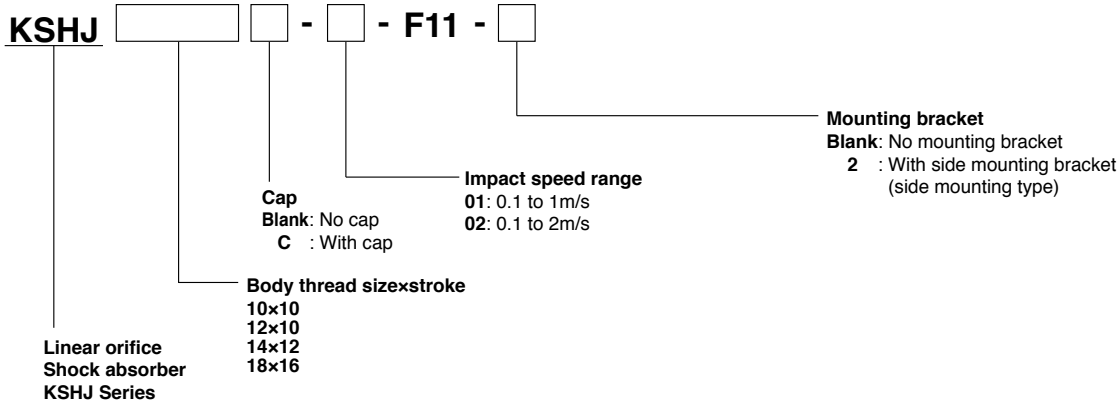

### • 25×25

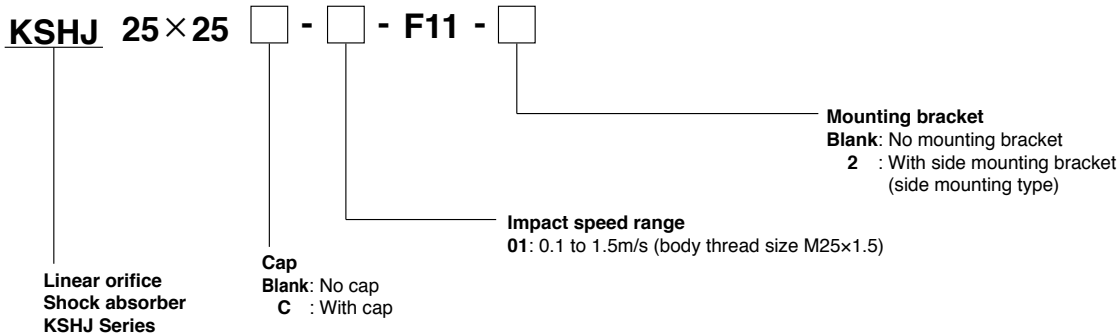

### • 30×30 36×50

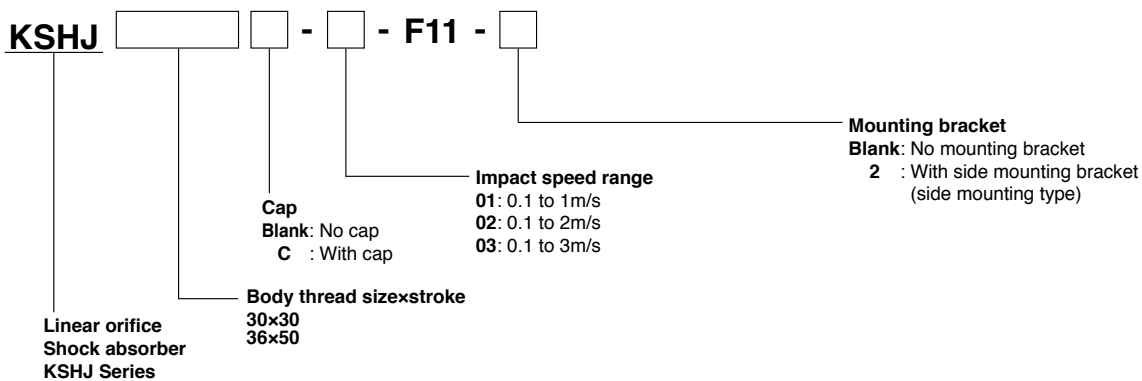

## Order Codes (specifications in inches)

- 42×50  
42×70

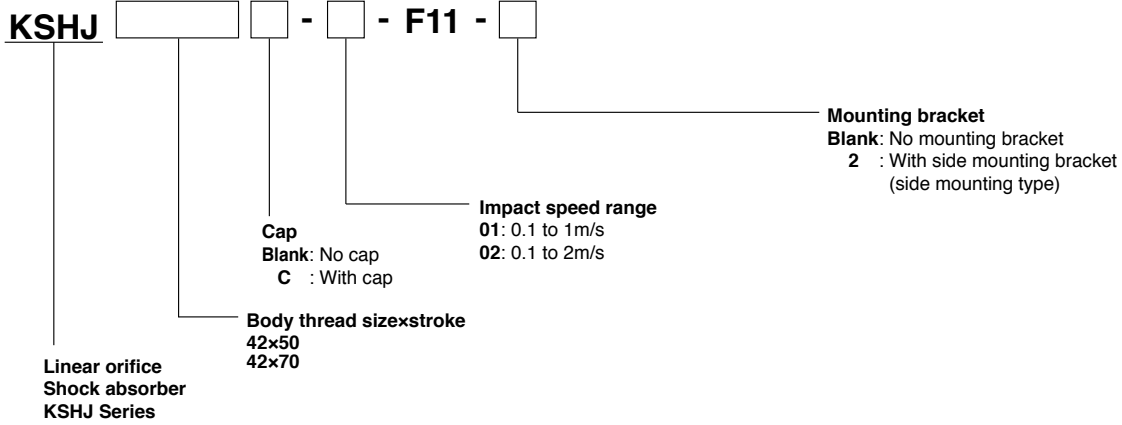

## Short stroke type (with hexagon socket)

- 8×4  
10×6  
12×6  
14×8

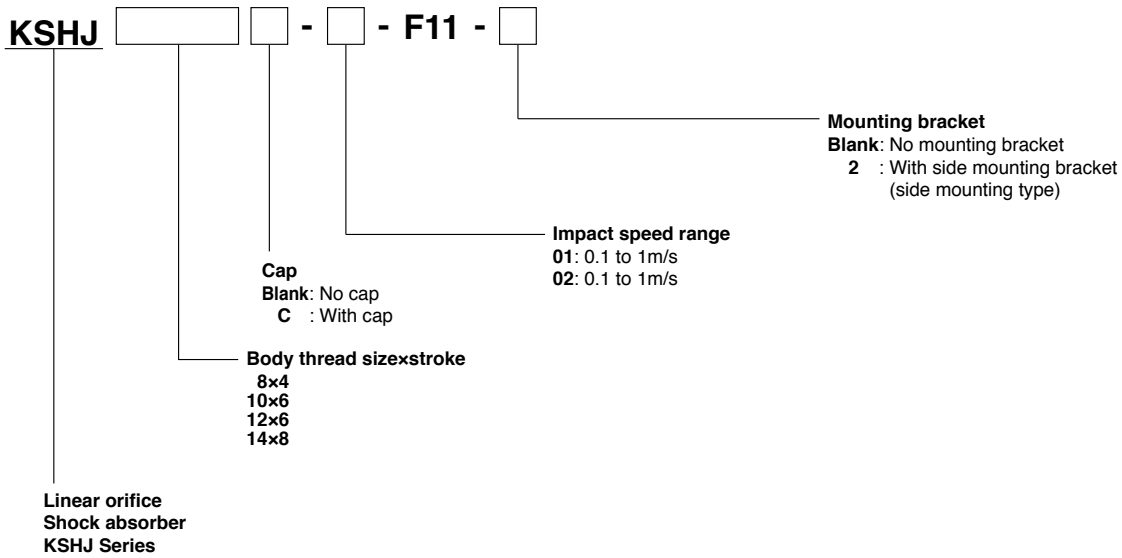

KSHJ

KSHY

KSHP

KSHC

Additional Parts

## Dimensions (in)

●No rod end cap: KSHJ4×3, KSHJ6×4, KSHJ6×6

●With rod end cap: KSHJ4×3C, KSHJ6×4C  
KSHJ6×6C

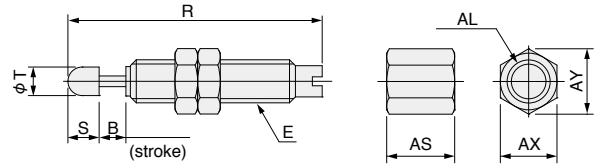
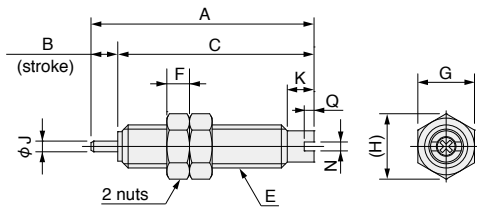

Model	Symbol	A	B	C	E	F	G	H	J	K	N	Q	R	S
KSHJ4×3 (C)-01,-02-F11		0.984	0.118	0.866	#10-32 UNF	0.1	1/4	0.289	0.047	0.118	0.039	0.043	1.122	0.138
KSHJ6×4 (C)-01,-02-F11		1.161	0.157	1.004	1/4-32 UNEF	0.1	3/8	0.433	0.079	0.177	0.039	0.039	1.319	0.157
KSHJ6×6 (C)-01,-02-F11		1.398	0.236	1.161	1/4-32 UNEF	0.1	3/8	0.433	0.079	0.217	0.039	0.039	1.555	0.157

Model	Symbol	T	AL	AS	AX	AY
KSHJ4×3 (C)-01,-02-F11		0.126	#10-32 UNF	0.3	1/4	0.289
KSHJ6×4 (C)-01,-02-F11		0.181	1/4-32 UNEF	0.4	3/8	0.433
KSHJ6×6 (C)-01,-02-F11		0.181	1/4-32 UNEF	0.4	3/8	0.433

●No rod end cap: KSHJ□×□-□

●With rod end cap: KSHJ□×□C-□

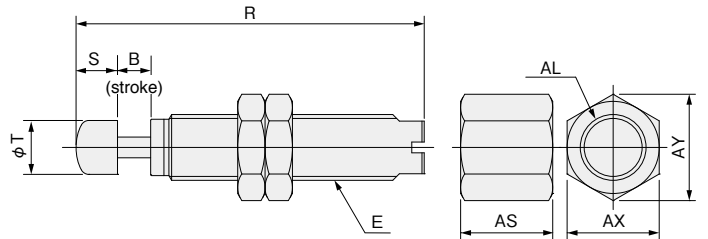
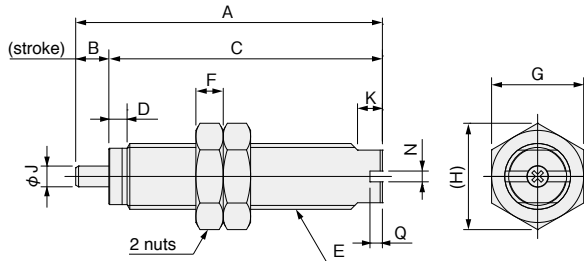

Model	Symbol	A	B	C	D	E	F	G	H	J	K	N	Q	R
KSHJ8×4 (C)-01,-02-F11		1.457	0.157	1.299	0.087	5/16-32 UNEF	0.13	7/16	0.505	0.098	0.118	0.051	0.059	1.654
KSHJ8×5 (C)-01-F11		1.457	0.197	1.26	0.047	5/16-32 UNEF	0.13	7/16	0.505	0.098	0.118	0.051	0.059	1.654
KSHJ8×8 (C)-01,-02-F11		1.811	0.315	1.496	0.047	5/16-32 UNEF	0.13	7/16	0.505	0.098	0.118	0.051	0.059	2.008
KSHJ10×6 (C)-01,-02-F11		1.89	0.236	1.654	0.079	3/8-32 UNEF	0.13	1/2	0.577	0.118	0.197	0.051	0.059	2.205
KSHJ10×10 (C)-01,-02-F11		2.362	0.394	1.969	0.079	3/8-32 UNEF	0.13	1/2	0.577	0.118	0.197	0.051	0.059	2.677
KSHJ10×15 (C)-01,-03-F11		3.031	0.591	2.441	0.079	3/8-32 UNEF	0.13	1/2	0.577	0.118	0.197	0.051	0.059	3.346
KSHJ11×6 (C)-01,-02-F11		1.89	0.236	1.654	0.079	7/16-28 UNEF	0.15	9/16	0.65	0.118	0.197	0.051	0.059	2.205
KSHJ11×10 (C)-01,-02-F11		2.362	0.394	1.969	0.079	7/16-28 UNEF	0.15	9/16	0.65	0.118	0.197	0.051	0.059	2.677
KSHJ11×15 (C)-01,-03-F11		3.031	0.591	2.441	0.079	7/16-28 UNEF	0.15	9/16	0.65	0.118	0.197	0.051	0.059	3.346
KSHJ12×6 (C)-01,-02-F11		1.89	0.236	1.654	0.079	1/2-20 UNF	0.15	5/8	0.722	0.118	0.197	0.051	0.059	2.283
KSHJ12×10 (C)-01,-02-F11		2.598	0.394	2.205	0.079	1/2-20 UNF	0.15	5/8	0.722	0.118	0.197	0.051	0.059	2.992
KSHJ14×8 (C)-01,-02-F11		2.402	0.315	2.087	0.079	9/16-18 UNF	7/32	11/16	0.794	0.157	0.197	0.051	0.059	2.795
KSHJ14×12 (C)-01,-02-F11		2.835	0.472	2.362	0.079	9/16-18 UNF	7/32	11/16	0.794	0.157	0.197	0.051	0.059	3.228
KSHJ18×16 (C)-01,-02-F11		3.465	0.63	2.835	0.118	3/4-16 UNF	1/4	15/16	1.082	0.197	0.276	0.071	0.079	4.055
KSHJ25×25 (C)-01,-02-F11		4.921	0.984	3.937	0.118	1-12 UNF	3/8	1 1/4	1.443	0.236	0.394	0.071	0.079	5.63

Model	Symbol	S	T	AL	AS	AX	AY
KSHJ8×4 (C)-01,-02-F11		0.197	0.256	5/16-32 UNEF	7/16	7/16	0.505
KSHJ8×5 (C)-01-F11		0.197	0.256	5/16-32 UNEF	7/16	7/16	0.505
KSHJ8×8 (C)-01,-02-F11		0.197	0.256	5/16-32 UNEF	7/16	7/16	0.505
KSHJ10×6 (C)-01,-02-F11		0.315	0.315	3/8-32 UNEF	11/16	1/2	0.577
KSHJ10×10 (C)-01,-02-F11		0.315	0.315	3/8-32 UNEF	11/16	1/2	0.577
KSHJ10×15 (C)-01,-03-F11		0.315	0.315	3/8-32 UNEF	11/16	1/2	0.577
KSHJ11×6 (C)-01,-02-F11		0.315	0.315	7/16-28 UNEF	11/16	9/16	0.65
KSHJ11×10 (C)-01,-02-F11		0.315	0.315	7/16-28 UNEF	11/16	9/16	0.65
KSHJ11×15 (C)-01,-03-F11		0.315	0.315	7/16-28 UNEF	11/16	9/16	0.65
KSHJ12×6 (C)-01,-02-F11		0.394	0.394	1/2-20 UNF	11/16	5/8	0.722
KSHJ12×10 (C)-01,-02-F11		0.394	0.394	1/2-20 UNF	11/16	5/8	0.722
KSHJ14×8 (C)-01,-02-F11		0.394	0.433	9/16-18 UNF	3/4	11/16	0.794
KSHJ14×12 (C)-01,-02-F11		0.394	0.433	9/16-18 UNF	3/4	11/16	0.794
KSHJ18×16 (C)-01,-02-F11		0.591	0.591	3/4-16 UNF	11/2	15/16	1.082
KSHJ25×25 (C)-01,-02-F11		0.709	0.709	1-12 UNF	11/2	1 1/4	1.443



## Dimensions (in)

### ● No rod end cap: KSHJ□×□-□

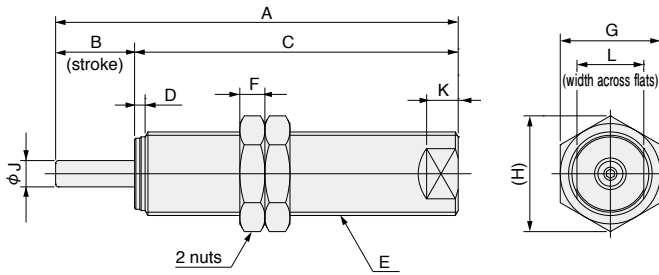

### ● With rod end cap: KSHJ□×□C-□

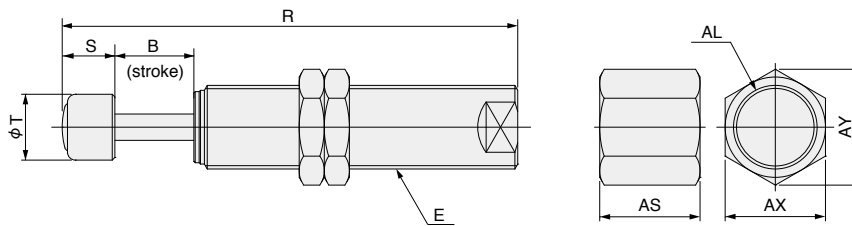

Model	Symbol	A	B	C	D	E	F	G	H	J	K	L	R	S
KSHJ30×30 (C)-01,-02,-03-F11		6.024	1.181	4.843	0.157	1 1/4-12 UNF	3/8	1 1/2	1.732	0.394	0.472	1	6.811	0.787
KSHJ36×50 (C)-01,-02,-03-F11		8.583	1.969	6.614	0.197	1 3/8-12 UNF	5/8	1 11/16	1.948	0.472	0.591	1 1/8	9.567	0.984
KSHJ42×50 (C)-01,-02-F11		8.661	1.969	6.693	0.197	1 3/4-12 UN	5/8	2	2.309	0.472	0.787	1 1/2	9.646	0.984
KSHJ42×70 (C)-01,-02-F11		10.827	2.756	8.071	0.197	1 3/4-12 UN	5/8	2	2.309	0.472	0.787	1 1/2	11.811	0.984

Model	Symbol	T	AL	AS	AX	AY
KSHJ30×30 (C)-01,-02,-03-F11		0.984	1 1/4-12 UNF	1 1/2	1 1/2	1.732
KSHJ36×50 (C)-01,-02,-03-F11		1.26	1 3/8-12 UNF	2	1 11/16	1.948
KSHJ42×50 (C)-01,-02-F11		1.26	1 3/4-12 UN	2	2	2.309
KSHJ42×70 (C)-01,-02-F11		1.26	1 3/4-12 UN	2	2	2.309

## Dimensions of Additional Parts (mm)

### ● Mounting nut: N-KSH-□-□

### N-KSH-M45 (for KSHJ45)

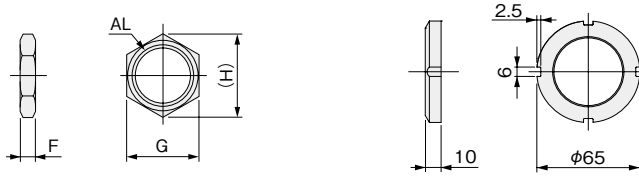

Symbol Model	AL	F	G	H	Applicable shock absorbers			
					KSHJ	KSHY	KSHP	CS-KSHC
N-KSH-M4	M4×0.5	2	5.5	6.4	KSHJ4	—	—	CS-KSHC3
N-KSH-M6	M6×0.75	2	8	9.2	KSHJ6	KSHY6	KSHP6	CS-KSHC4
N-KSH-M8	M8×0.75	2	10	11.5	KSHJ8(-01,02)	KSHY8(-01,02)	KSHP8	CS-KSHC5
N-KSH-M8-11	M8×1	3	10	11.5	KSHJ8(-11,12)	KSHY8(-11,12)	KSHP8-11	CS-KSHC5-11
N-KSH-M10	M10×1	3	12	13.9	KSHJ10	KSHY10	KSHP10	CS-KSHC6
N-KSH-M12	M12×1	4	14	16.2	KSHJ12	KSHY12	KSHP12	CS-KSHC8
N-KSH-M14	M14×1.5	5	17	19.6	KSHJ14	KSHY14	KSHP14	CS-KSHC9
N-KSH-M16	M16×1.5	7	19	21.9	KSHJ16	KSHY16	KSHP16	CS-KSHC11
N-KSH-M18	M18×1.5	8	21	24.2	KSHJ18	—	KSHP18	—
N-KSH-M20	M20×1.5	8	24	27.7	KSHJ20	KSHY20	KSHP20	CS-KSHC14
N-KSH-M22	M22×1.5	9	27	31.2	KSHJ22	—	—	—
N-KSH-M25	M25×1.5	10	30	34.6	KSHJ25-01	—	KSHP25	CS-KSHC18
N-KSH-M25-11	M25×2	10	30	34.6	KSHJ25(-11,12)	—	—	—
N-KSH-M27	M27×1.5	10	36	41.6	KSHJ27(-01,02)	—	—	—
N-KSH-M27-11	M27×3	12	36	41.6	KSHJ27(-11,12)	—	—	—
N-KSH-M30	M30×1.5	10	36	41.6	KSHJ30	—	KSHP30	—
N-KSH-M33	M33×1.5	10	41	47.3	KSHJ33	—	—	—
N-KSH-M36	M36×1.5	15	46	53.1	KSHJ36	—	KSHP36	—
N-KSH-M42	M42×1.5	15	50	57.7	KSHJ42	—	KSHP42	—
N-KSH-M48	M48×2	15	55	63.5	KSHJ48	—	—	—

### ● Stopper nut: S-KSH-□-□ (-2)

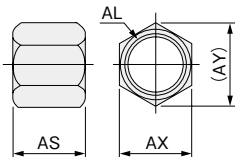

Symbol Model	AL	AS	AX	AY	Applicable shock absorbers			
					KSHJ	KSHY	KSHP	CS-KSHC
S-KSH-M4	M4×0.5	7.5	5.5	6.4	KSHJ4	—	—	CS-KSHC3
S-KSH-M6	M6×0.75	7	8	9.2	KSHJ6	—	KSHP6	CS-KSHC4
S-KSH-M6-L	M6×0.75	10	8	9.2	—	KSHY6	—	—
S-KSH-M8	M8×0.75	11	10	11.5	KSHJ8(-01,02)	KSHY8(-01,02)	KSHP8	CS-KSHC5
S-KSH-M8-11	M8×1	11	10	11.5	KSHJ8(-11,12)	KSHY8(-11,12)	KSHP6-11	CS-KSHC5-11
S-KSH-M10	M10×1	17	12	13.9	KSHJ10	KSHY10	KSHP10	CS-KSHC6
S-KSH-M12	M12×1	17	14	16.2	KSHJ12	KSHY12	KSHP12	CS-KSHC8
S-KSH-M14	M14×1.5	18	17	19.6	KSHJ14	KSHY14	KSHP14	CS-KSHC9
S-KSH-M16	M16×1.5	30	19	21.9	KSHJ16	KSHY16	KSHP16	CS-KSHC11
S-KSH-M18	M18×1.5	35	21	24.2	KSHJ18	—	KSHP18	—
S-KSH-M20	M20×1.5	35	24	27.7	KSHJ20	KSHY20	KSHP20	CS-KSHC14
S-KSH-M22	M22×1.5	40	27	31.2	KSHJ22	—	—	—
S-KSH-M25	M25×1.5	40	30	34.6	KSHJ25-01	—	KSHP25	CS-KSHC18
S-KSH-M25-11	M25×2	40	30	34.6	KSHJ25(-11,12)	—	—	—
S-KSH-M27	M27×1.5	40	36	41.6	KSHJ27(-01,02)	—	—	—
S-KSH-M27-11	M27×3	40	36	41.6	KSHJ27(-11,12)	—	—	—
S-KSH-M30	M30×1.5	40	36	41.6	KSHJ30	—	KSHP30	—
S-KSH-M33	M33×1.5	40	41	47.3	KSHJ33	—	—	—
S-KSH-M36	M36×1.5	50	46	53.1	KSHJ36	—	KSHP36	—
S-KSH-M42	M42×1.5	50	50	57.7	KSHJ42	—	KSHP42	—
S-KSH-M45	M45×1.5	60	55	63.5	KSHJ45	—	—	—
S-KSH-M48	M48×2	60	55	63.5	KSHJ48	—	—	—

## Dimensions of Additional Parts (mm)

### ●Side mounting bracket: 2-KSH-□-□ (-2)

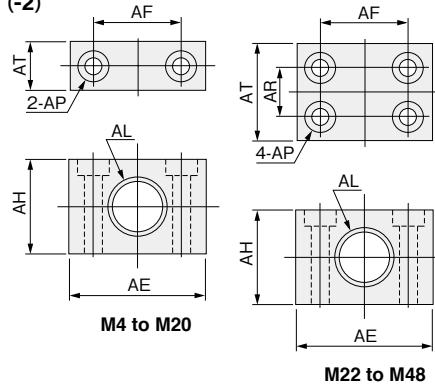

Symbol Model	AE	AF	AH	AL	AP	AR	AT	Applicable shock absorbers			
								KSHJ	KSHY	KSHP	CS-KSHC
2-KSH-M4	18	12	8	M4×0.5	φ 3.4, φ 6.5 Counter bore depth3.3	—	8	KSHJ4	—	—	CS-KSHC3
2-KSH-M6	18	12	10	M6×0.75	φ 3.4, φ 6.5 Counter bore depth3.3	—	8	KSHJ6	KSHY6	KSHP6	CS-KSHC4
2-KSH-M8	19	13	13	M8×0.75	φ 3.4, φ 6.5 Counter bore depth3.3	—	9	KSHJ8(-01,02)	KSHY8(-01,02)	KSHP8	CS-KSHC5
2-KSH-M8-11	19	13	13	M8×1	φ 3.4, φ 6.5 Counter bore depth3.3	—	9	KSHJ8(-11,12)	KSHY8(-11,12)	KSHP8-11	CS-KSHC5-11
2-KSH-M10	22	14	14	M10×1	φ 3.4, φ 6.5 Counter bore depth3.3	—	9	KSHJ10	KSHY10	KSHP10	CS-KSHC6
2-KSH-M12	25	16	18	M12×1	φ 3.4, φ 6.5 Counter bore depth3.3	—	9	KSHJ12	KSHY12	KSHP12	CS-KSHC8
2-KSH-M14	34	22	22	M14×1.5	φ 4.5, φ 8 Counter bore depth4.5	—	10	KSHJ14	KSHY14	KSHP14	CS-KSHC9
2-KSH-M16	38	25	25	M16×1.5	φ 4.5, φ 8 Counter bore depth4.5	—	12	KSHJ16	KSHY16	KSHP16	CS-KSHC11
2-KSH-M18	50	34	30	M18×1.5	φ 6.5, φ 11 Counter bore depth6.5	—	12	KSHJ18	—	KSHP18	—
2-KSH-M20	50	34	30	M20×1.5	φ 9, φ 14 Counter bore depth8.5	—	16	KSHJ20	KSHY20	KSHP20	CS-KSHC14
2-KSH-M22	60	44	35	M22×1.5	φ 9, φ 14 Counter bore depth8.5	19	35	KSHJ22	—	—	—
2-KSH-M25	60	44	35	M25×1.5	φ 9, φ 14 Counter bore depth8.5	19	35	KSHJ25-01	—	KSHP25	CS-KSHC18
2-KSH-M25-11	60	44	35	M25×2	φ 9, φ 14 Counter bore depth8.5	19	35	KSHJ25(-11,12)	—	—	—
2-KSH-M27	60	44	44	M27×1.5	φ 9, φ 14 Counter bore depth8.5	19	35	KSHJ27(-01,02)	—	—	—
2-KSH-M27-11	60	44	44	M27×3	φ 9, φ 14 Counter bore depth8.5	19	35	KSHJ27(-11,12)	—	—	—
2-KSH-M30	60	44	46	M30×1.5	φ 9, φ 14 Counter bore depth8.5	19	35	KSHJ30	—	KSHP30	—
2-KSH-M33	100	70	62	M33×1.5	φ 18, φ 26 Counter bore depth18	50	80	KSHJ33	—	—	—
2-KSH-M36	100	70	62	M36×1.5	φ 18, φ 26 Counter bore depth18	50	80	KSHJ36	—	KSHP36	—
2-KSH-M42	100	70	62	M42×1.5	φ 18, φ 26 Counter bore depth18	50	80	KSHJ42	—	KSHP42	—
2-KSH-M45	120	85	70	M45×1.5	φ 22, φ 32 Counter bore depth22	45	80	KSHJ45	—	—	—
2-KSH-M48	120	85	70	M48×2	φ 22, φ 32 Counter bore depth22	45	80	KSHJ48	—	—	—

# Limited Warranty

KOGANEI CORP. warrants its products to be free from defects in material and workmanship subject to the following provisions.

**Warranty Period** The warranty period is 180 days from the date of delivery.

**Koganei Responsibility** If a defect in material or workmanship is found during the warranty period, KOGANEI CORP. will replace any part proved defective under normal use free of charge and will provide the service necessary to replace such a part.

**Limitations**

- This warranty is in lieu of all other warranties, expressed or implied, and is limited to the original cost of the product and shall not include any transportation fee, the cost of installation or any liability for direct, indirect or consequential damage or delay resulting from the defects.

- KOGANEI CORP. shall in no way be liable or responsible for injuries or damage to persons or property arising out of the use or operation of the manufacturer's product.

- This warranty shall be void if the engineered safety devices are removed, made inoperative or not periodically checked for proper functioning.

- Any operation beyond the rated capacity, any improper use or application, or any improper installation of the product, or any substitution upon it with parts not furnished or approved by KOGANEI CORP., shall void this warranty.

- This warranty covers only such items supplied by KOGANEI CORP. The products of other manufacturers are covered only by such warranties made by those original manufacturers, even though such items may have been included as the components.

The specifications are subject to change without notice.

URL <http://www.koganei.co.jp>

E-mail: [overseas@koganei.co.jp](mailto:overseas@koganei.co.jp)



## KOGANEI CORPORATION

### OVERSEAS DEPARTMENT

3-11-28, Midori-cho, Koganei City, Tokyo 184-8533, Japan  
Tel: 81-42-383-7271 Fax: 81-42-383-7276

### KOGANEI INTERNATIONAL AMERICA, INC.

39300 Civic Center Dr., Suite 280, Fremont, CA 94538, U.S.A.  
Tel: 1-510-744-1626 Fax: 1-510-744-1676

### SHANGHAI KOGANEI INTERNATIONAL TRADING CORPORATION

Room 2606-2607, Tongda Venture Building No.1, Lane 600, Tianshan Road,  
Shanghai, 200051, China  
Tel: 86-21-6145-7313 Fax: 86-21-6145-7323

### TAIWAN KOGANEI TRADING CO., LTD.

Rm. 2, 13F., No88, Sec. 2, Zhongxiao E. Rd., Zhongzheng Dist., Taipei City 100,  
Taiwan (ROC)  
Tel: 886-2-2393-2717 Fax: 886-2-2393-2719

### KOGANEI KOREA CO., LTD.

KT&G Cosmo Bldg., 3F, 40-13, Maesanno 2-ga, Paldal-gu, Suwon-si, Gyeonggi-do,  
442-847, Korea  
Tel: 82-31-246-0414 Fax: 82-31-246-0415

### KOGANEI (THAILAND) CO., LTD.

3300/90, Tower B, Elephant Tower, 16th Fl., Phaholyothin Road, Chomphon,  
Chatuchak, Bangkok 10900, Thailand  
Tel: 66-2-937-4250 Fax: 66-2-937-4254

### KOGANEI ASIA PTE. LTD.

12 Arumugam road #03-12, Lion Building B, 409958, Singapore  
Tel: 65-6293-4512 Fax: 65-6293-4513